

4

3

2

1

REVISONS					
REV. NO.	ZONE:	DATE:	ECN NO.	APPVD:	DESCRIPTION
01	-	12/01/08	-	SH	RELEASE FOR PRODUCTION

BRAND	MODEL
CLOPAY	902C, 902D, 902I 902M, 902P, 902T
IDEAL	C2ALC, C2ALD, C2ALI, C2ALM, C2ALP, C2ALT

MODEL 902 IS MADE OF 6063-T5 ALUMINUM EXTRUSIONS. WALL THICKNESS:
 TOP & BOTTOM RAILS .075
 INTER. TOP & BOTTOM RAILS .075
 TOP HAS .1 x 1.875" FIN
 INTER. TOP RAIL CAP .040
 SINGLE & DOUBLE END STILES .075
 CENTER STILES .062

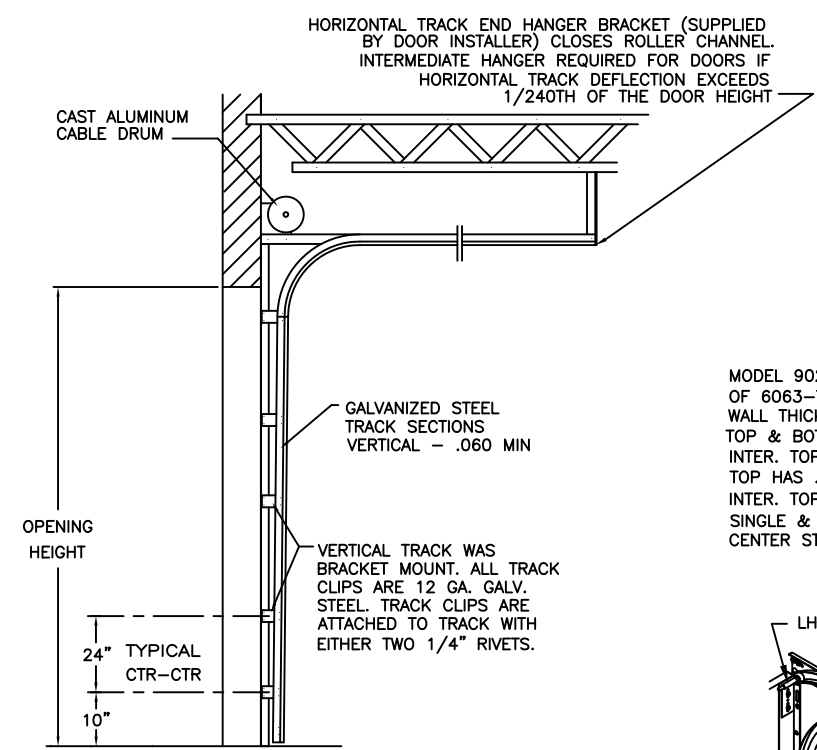

**SIDE ELEVATION
STANDARD-LIFT TRACK DETAILS**

NOTE: DOUBLE TRACK LOW HEADROOM, HI-LIFT TRACK, FOLLOW-THE-ROOF TRACK, AND VERTICAL LIFT TRACK ARE AVAILABLE OPTIONS.

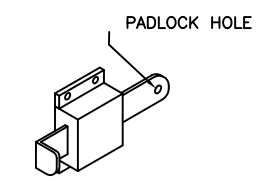
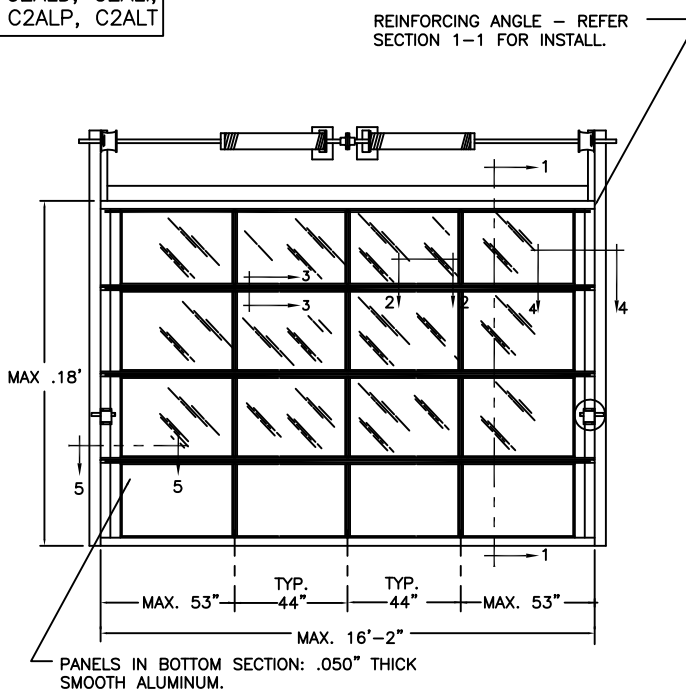
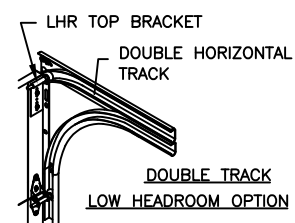

SPRING LOADED SLIDE BOLT LOCK. (2) PER DOOR. MOUNT WITH (4) #14 X 5/8" LG. SHT. MTL. SCREWS.

VIEW 'A'

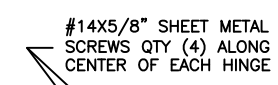

#14X5/8" SHEET METAL SCREWS QTY (4) ALONG CENTER OF EACH HINGE

14 GAUGE END HINGES

SECTION 1 - 1

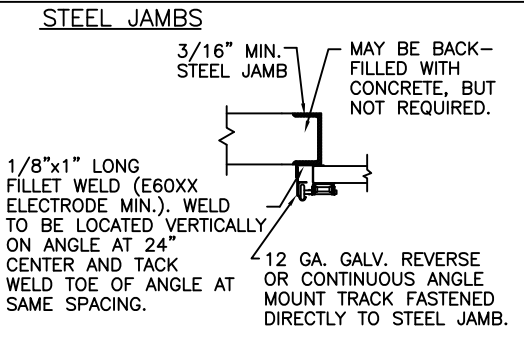
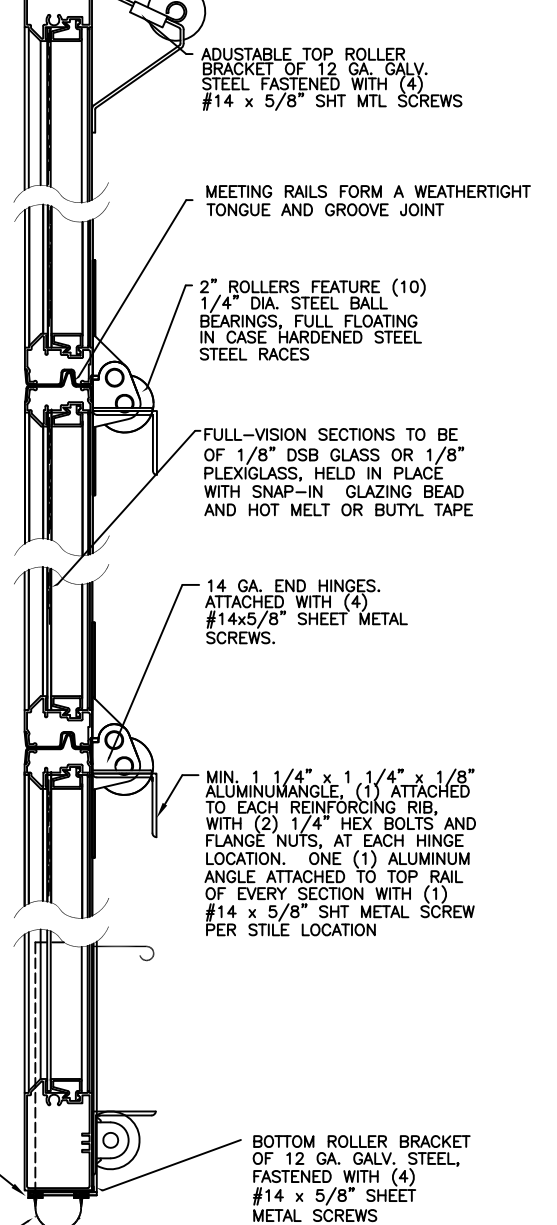

CENTER STILES FASTENED TO RAILS WITH FULL LENGTH 5/16" ALUMINUM RODS AND FLANGE NUTS



COR-LOVLY CENTER HINGE OF 16 GA. GALV. STEEL, ATTACHED TO INTER. BOTTOM RAIL WITH (2) #14 X 5/8" SHT MTL SCREWS AND TO INTER. TOP RAIL WITH (2) 1/4" - 20 X 1/2" HEX HEAD MACHINE SCREWS & NUTS

SECTION 2 - 2

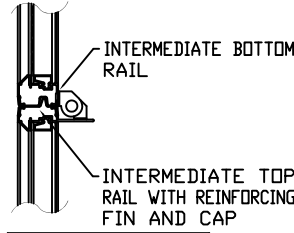

SECTION 3 - 3

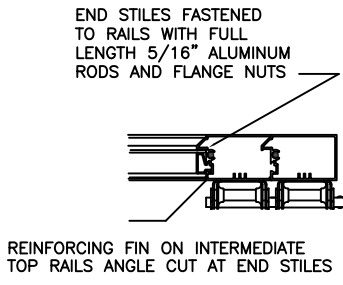

SECTION 4-4

ANCHOR NOTE: FIRST (BOTTOM) ANCHOR STARTING AT NO MORE THAN HALF OF THE MAXIMUM ON-CENTER DISTANCE. HIGHEST ANCHOR INSTALLED AT LEAST AS HIGH AS THE DOOR OPENING.

WOOD JAMB ON CONCRETE

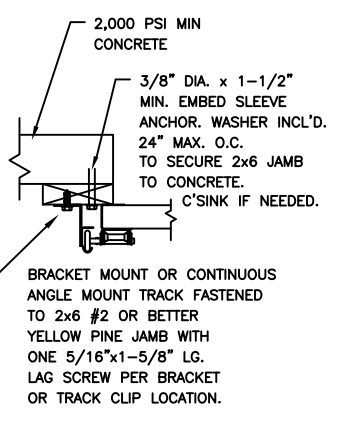

CONCRETE JAMBS

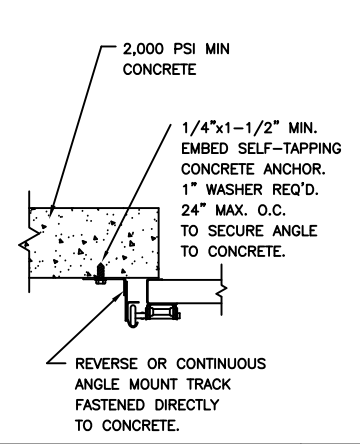

SECTION 5 - 5

STEEL JAMBS

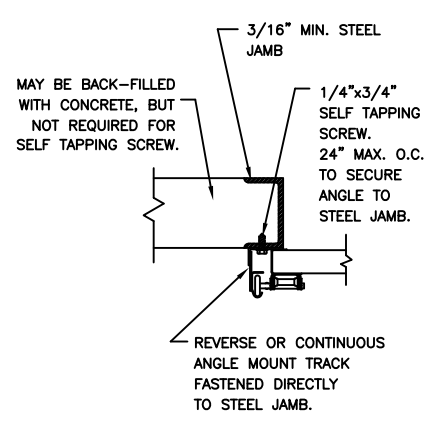

WOOD JAMBS

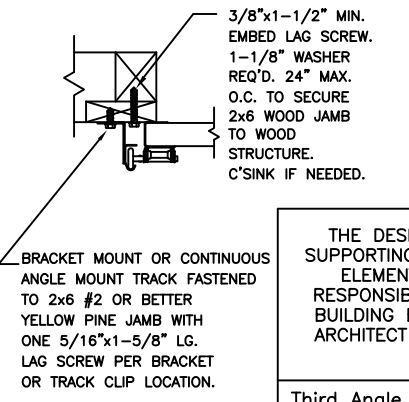

MARK WESTERFIELD, P.E.
FLORIDA P.E. #48495, NC P.E. #23832,
TEXAS P.E. #91513

DESIGN LOADS: +13.5 PSF & -13.5 PSF
TEST LOADS: +20.0 PSF & -20.0 PSF

THE DESIGN OF THE SUPPORTING STRUCTURAL ELEMENTS IS THE RESPONSIBILITY OF THE BUILDING ENGINEER OR ARCHITECT OF RECORD.

Unless Stated Otherwise TOLERANCES are
 .0 = ±.03
 .00 = ±.015
 .000 = ±.005
 .0000 = ±.001
 Degrees = ±1/2"

Clopay Building Products Company
8585 Duke Boulevard
Mason, OH 45040
Tel. No. 1-513-381-4800
Fax No. 1-513-762-3519

MPC: C-AL-1F499

CLOPAY WINDLOAD RATING
W1

DESCRIPTION: 902DW1/902IW1/902MW1 16' WIDE

DRAWN BY: BFA DATE: 2/03/06 SCALE: NTS DWG. B

CHECKED BY: SH DATE: 02/2006 SHEET 1 OF 1 SIZE B

DWG. NO.: 103610 REV. NO. 01

4

3

2

1