

MODELS AVAILABLE (CLOPAY/ HOLMES/ IDEAL)
524W8, 520W8 / 224W8 / C4STW8, COSTW8

SHEET:
1 OF 3

REVISIONS					
REV. NO.	ZONE:	DATE:	ECN NO.	APPVD:	DESCRIPTION
00	-	1/30/14	-	SH	INITIAL RELEASE.

DOOR WIDTH	NUMBER OF CENTER STILES
UP TO 6' 2"	2
6'-3" THRU 8'-2"	3
8'-3" THRU 10'-2"	4
10'-3" THRU 12'-2"	5

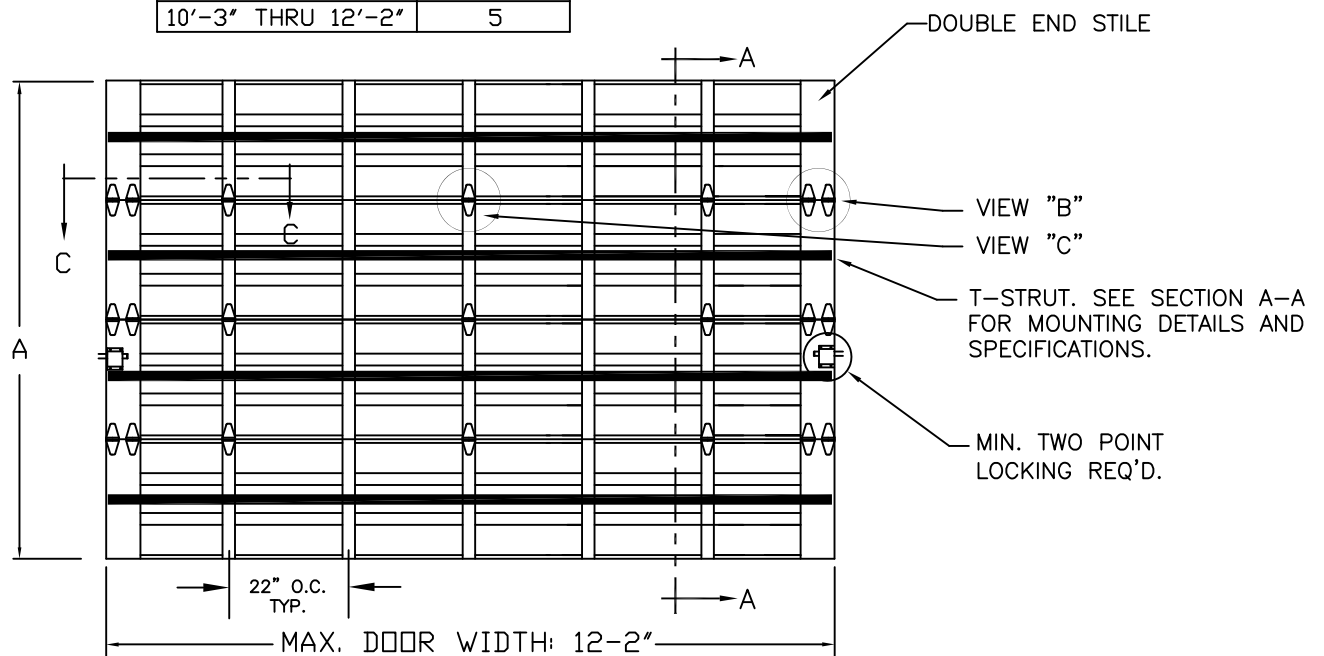

THIS DOOR MEETS THE REQUIREMENTS OF THE LARGE MISSILE IMPACT AND CYCLIC TESTING.

DOOR HEIGHT 'A'	NUMBER OF SECTIONS
UP TO 8'-0"	4
8'-3" THRU 10'-0"	5
10'-3" THRU 12'-0"	6
12'-3" THRU 14'-0"	7
14'-3" THRU 16'-0"	8
16'-3" THRU 18'-0"	9

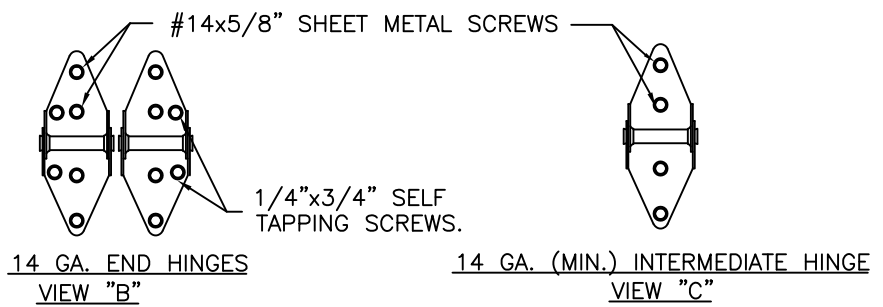

THIS DOOR MEETS OR EXCEEDS THE DESIGN LOADS FOR THE ULTIMATE WIND SPEEDS LISTED BELOW ACCORDING TO THE FLORIDA BUILDING CODE OR THE INTERNATIONAL BUILDING CODE (BASED ON ASCE7-05) FOR THE FOLLOWING CONDITIONS: 1) ENCLOSED BUILDING, 2) DOOR HAS 2' OF WIDTH IN BUILDING'S END ZONE, 3) ROOF SLOPE <10°, AND 4) TESTING IN ACCORDANCE WITH ANSI/DASMA 108. SITE-SPECIFIC CALCULATIONS BY A QUALIFIED DESIGN PROFESSIONAL MAY DIFFER.

WIND SPEED (MPH)	165	170	190
EXPOSURE CATEGORY	B, C	B, C	B
MEAN ROOF HEIGHT	25'	15'	30'

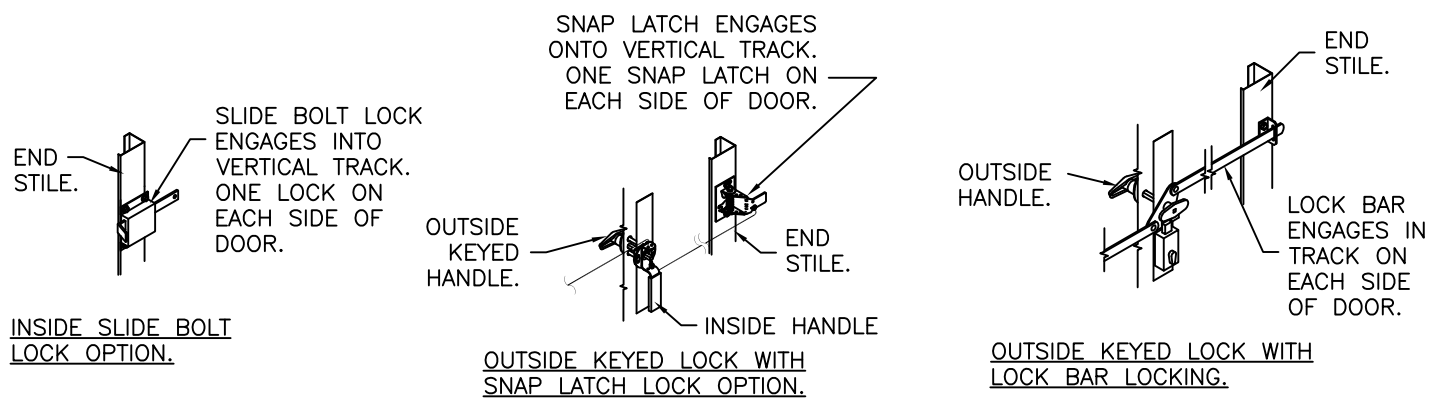

DESIGN LOADS: +52.0 P.S.F. & -58.0 P.S.F.
TEST LOADS: +78.0 P.S.F. & -87.0 P.S.F.

Unless Stated Otherwise
TOLERANCES are
.0 = ±.031
.00 = ±.015
.000 = ±.005
.0000 = ±.001
Degrees = ±1/2'

Glopay Building Products Company
8585 Duke Boulevard
Mason, OH 45040 USA
Tel. No. 513-770-4800
Fax No. 513-770-4853

MANUFACTURING PRODUCT CODE
C-PAN-1E448

PART NO.: N/A

WINDLOAD RATING
W8 DP52T

DESCRIPTION: COMMERCIAL RIBBED DOORS UP TO 12'2"W (SEE TABLE)

DRAWN BY: SH DATE: 1/10/13 SCALE: NTS DWG. B

CHECKED BY: SH DATE: 1/10/13 SHEET 1 OF 3 SIZE B

DWG. NO.: 104813 VER: TDI

DESIGN ENGINEER:
MARK WESTERFIELD, P.E.
FLORIDA P.E. #48495, NC P.E. #23832, TEXAS P.E. #91513

MODELS AVAILABLE (CLOPAY/ HOLMES/ IDEAL)
524W8, 520W8 / 224W8 / C4STW8, COSTW8

SHEET:
2 OF 3

REVISIONS					DESCRIPTION
REV. NO.	ZONE:	DATE:	ECN NO.	APPVD:	
00	-	-	-	SH	SEE REVISION HISTORY ON SHEET ONE.

D
C
B
A

D
C
B
A

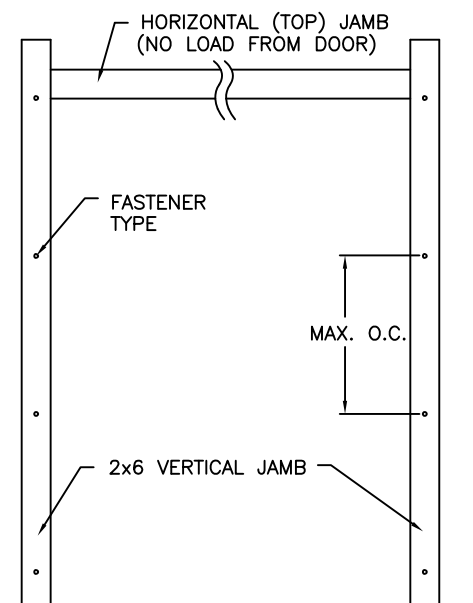

JAMB TO SUPPORTING STRUCTURE ATTACHMENT

- NOTES:**
1. ALL THE LOAD FROM THE DOOR IS TRANSFERRED TO THE TRACK AND THEN FROM THE TRACK TO THE 2x6 VERTICAL SYP (GRADE #2 OR BETTER) JAMBS. NO LOAD FROM THE DOOR IS TRANSFERRED TO THE HORIZONTAL (TOP) JAMB.
 2. EACH VERTICAL JAMB SEES A MAXIMUM DESIGN LOAD OF +312 LB & -348 LB. PER LINEAR FOOT OF JAMB.
 3. ALL JAMB FASTENERS MAY BE (BUT ARE NOT REQUIRED TO BE) COUNTERSUNK TO PROVIDE A FLUSH MOUNTING SURFACE.
 4. A 1/3 STRESS INCREASE FOR WIND LOAD WAS NOT USED IN THE CALCULATION OF ALLOWABLE LOADS FOR ANCHORS AND FASTENERS FOR STEEL, CONCRETE AND MASONRY.

NOTE: 2x6 WOOD JAMBS ARE NOT REQUIRED WITH CONTINUOUS ANGLE MOUNT TRACK. HOWEVER, IF DESIRED ON STEEL JAMBS OR CONCRETE OR BLOCK WALLS, APPROVED FASTENERS AS DETAILED BELOW SHOULD BE INCREASED IN LENGTH BY 1-1/2" AND INSTALLED DIRECTLY THROUGH THE ANGLE AND 2x6 WOOD JAMBS INTO THE STEEL JAMBS OR CONCRETE OR BLOCK WALLS. ANCHORS CAN BE (BUT ARE NOT REQUIRED TO BE) COUNTERSUNK TO PROVIDE A FLUSH MOUNTING SURFACE. CONTINUOUS ANGLE TRACK CAN BE ANCHORED DIRECTLY TO GROUT REINFORCED BLOCK WALL OR 3,000 PSI MIN. CONCRETE COLUMN OR STEEL JAMBS.

FASTENER ATTACHMENT TO SUPPORTING STRUCTURE SCHEDULES

BUILDING TYPE	FASTENER TYPE	MAXIMUM ON-CENTER DISTANCE BETWEEN FASTENERS*	STEEL WASHERS REQUIRED?
HOLLOW BLOCK WALL	1/4" x 1-1/4" MIN. EMBED ULTRACON CONCRETE ANCHOR	5-1/4"	1" O.D.
GROUT FILLED BLOCK WALL	1/4" x 1-3/4" MIN. EMBED ULTRACON CONCRETE ANCHOR	8-3/4"	1" O.D.
2000 PSI MIN. CONCRETE	1/4" x 1" MIN. EMBED ULTRACON CONCRETE ANCHOR	7-1/2"	1" O.D.
2000 PSI MIN. CONCRETE	1/4" x 1" MIN. EMBED TAPCON CONCRETE ANCHOR	6-1/2"	1" O.D.
2000 PSI MIN. CONCRETE	3/8" x 1-3/4" MIN. EMBED WEJ-IT ANKR TITE SLEEVE ANCHOR	16"	INCLUDED
4000 PSI MIN. CONCRETE	3/8" x 1-3/4" MIN. EMBED WEJ-IT ANKR TITE SLEEVE ANCHOR	24"	INCLUDED
WOOD FRAME (SYP 0.55 SG)	1/2" x 3" LAG SCREW (ASTM A307, GRADE A) 1-5/8" EMBED INTO STRUCTURE	17-1/2"	1" O.D.
14GA STEEL (0.060" MIN.)	1/4"-14 x 1" ITW BUILDEX TEKS SELF-DRILLING FASTENER	7-1/4"	1" O.D.
12GA STEEL (0.105" MIN.)	1/4"-14 x 1" ITW BUILDEX TEKS SELF-DRILLING FASTENER	12-3/4"	1" O.D.
1/8" STEEL	1/4"-14 x 1" ITW BUILDEX TEKS SELF-DRILLING FASTENER	15-1/4"	1" O.D.

* FIRST (BOTTOM) ANCHOR STARTING AT NO MORE THAN HALF OF THE MAXIMUM ON-CENTER DISTANCE. HIGHEST ANCHOR INSTALLED AT LEAST AS HIGH AS THE DOOR OPENING.
CLOPAY DOES NOT SUPPLY JAMB ATTACHMENT FASTENERS.
MINIMUM DISTANCE BETWEEN CENTER OF ANCHOR AND EDGE OF CONCRETE BLOCK: 2-1/2", EXCLUDING STUCCO THICKNESS.

DESIGN ENGINEER:
MARK WESTERFIELD, P.E.
FLORIDA P.E. #48495, NC P.E. #23832, TEXAS P.E. #91513

SECTIONS ARE 1-7/8" THICK PANELS ROLL FORMED OF .022" MIN. HOT DIPPED G-40 GALVANIZING, ROLL FORMED STEEL.

ADJUSTABLE TOP ROLLER BRACKET OF 12 GA. GALV. STEEL, INSTALLED ON DOOR WITH (4) #14 X 5/8" LG SHEET METAL SCREWS

ONE 4" T-STRUT PER SECTION. (SEE VIEW "D") EACH T-STRUT ATTACHED AT EACH STILE LOCATION WITH (2) 1/4"x3/4" SELF TAPPING SCREWS.

END HINGE. SEE DETAILS AT VIEW "B" ON SHEET 1.

TONGUE & GROOVE JOINT.

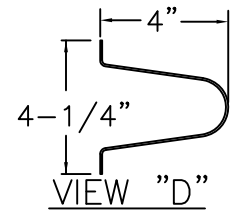

4" TALL TAPER STRUT. 0.057" MIN. GALV. STEEL, 50 KSI. MIN.

(2) STACKED LHR BRACKETS USED AS INNER BOTTOM BRACKET (NOT SHOWN).

BOTTOM ROLLER BRACKET OF 12 GA. MIN. GALV. STEEL, FASTENED WITH (4) #14 X 5/8" LG SHT. MTL. SCREWS

BOTTOM SECTION REINFORCED WITH TEMPERED ALUMINUM EXTRUSION WITH INTEGRAL RETAINER FOR FLEXIBLE VINYL ASTRAGAL

SECTION A-A (SIDE VIEW)

DESIGN LOADS: +52.0 P.S.F. & -58.0 P.S.F.
TEST LOADS: +78.0 P.S.F. & -87.0 P.S.F.

Unless Stated Otherwise TOLERANCES are
.0 = ±.031
.00 = ±.015
.000 = ±.005
.0000 = ±.001
Degrees = ±1/2"
Unless Stated Otherwise DIMENSIONS ARE IN INCHES.

Clopay
Building Products Company
8585 Duke Boulevard
Mason, OH 45040 USA
Tel. No. 513-770-4800
Fax No. 513-770-4853

MANUFACTURING PRODUCT CODE
C-PAN-1E448

PART NO.: N/A

WINDLOAD RATING
W8 DP52T

DESCRIPTION: COMMERCIAL RIBBED DOORS UP TO 12'2"W (SEE TABLE)			
DRAWN BY: SH	DATE: 1/10/13	SCALE: NTS	DWG. B
CHECKED BY: SH	DATE: 1/10/13	SHEET 2 OF 3	SIZE B
DWG. NO.: 104813	VER: TDI		

4

3

2

1

MODELS AVAILABLE (CLOPAY/ HOLMES/ IDEAL)
524W8, 520W8 / 224W8 / C4STW8, COSTW8

SHEET:
3 OF 3

REVISIONS

REV. NO.	ZONE:	DATE:	ECN NO.	APPVD:	DESCRIPTION
00	-	-	-	SH	SEE REVISION HISTORY ON SHEET ONE.

2" TRACK CONFIGURATION
DOORS UP TO 800 LBS.

NOTE DOUBLE TRACK HEADROOM, HI-LIFT TRACK, FOLLOW-THE-ROOF TRACK, AND VERTICAL LIFT TRACK ARE AVAILABLE OPTIONS. TRACK CONFIGURATION ABOVE THE DOOR OPENING DOES NOT AFFECT THE WIND LOAD RATING.

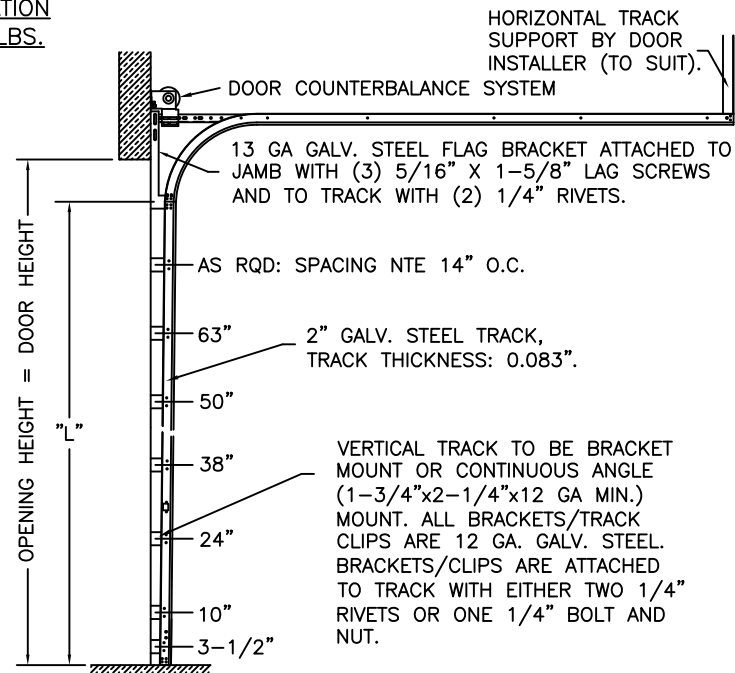

DOOR HEIGHT	"L"
6'-6"	70"
7'-0"	76"
7'-6"	82"
8'-0"	88"
8'-6"	94"
9'-0"	100"
9'-6"	106"
10'-0"	112"
10'-6"	118"
11'-0"	124"
11'-6"	130"
12'-0"	136"
12'-6"	142"
13'-0"	148"
13'-6"	154"
14'-0"	160"
14'-6"	166"
15'-0"	172"
15'-6"	178"
16'-0"	184"
16'-6"	190"
17'-0"	196"
17'-6"	202"
18'-0"	208"

JAMB CONFIGURATION
DOORS UP TO 800 LBS.

BRACKET MOUNT JAMB CONFIGURATION

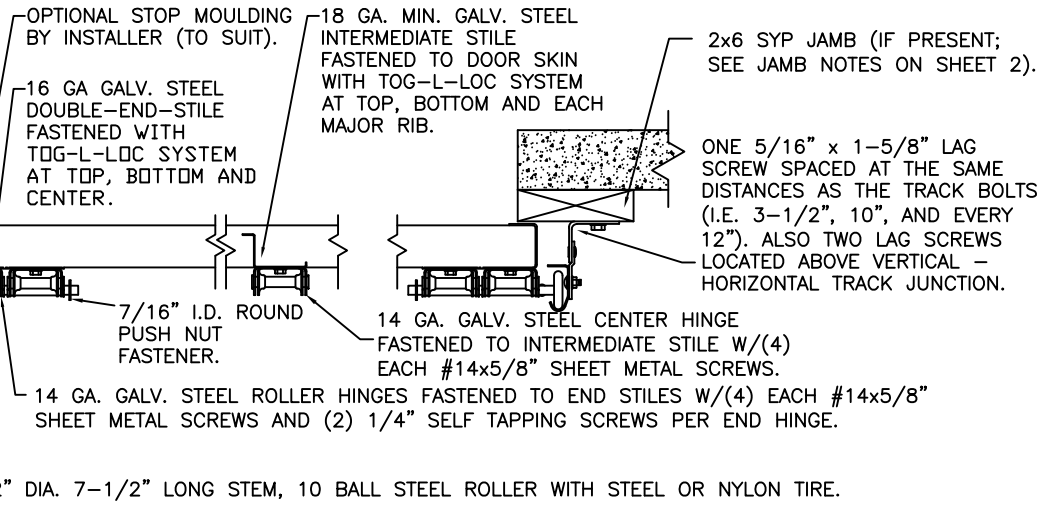
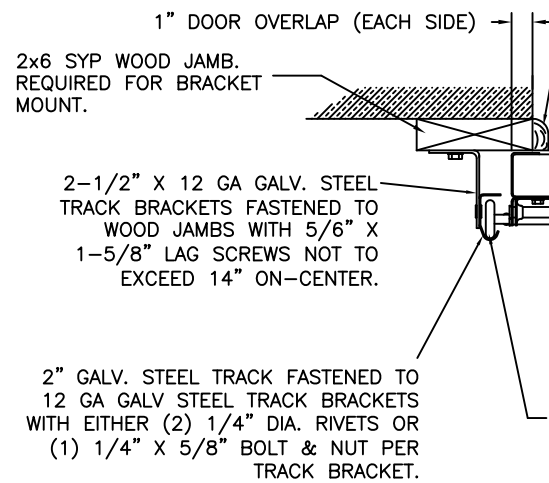

SECTION C-C

PREPARATION OF JAMBS BY OTHERS.

LHR BRACKET (2-1/2" x 5-3/4" x 12GA) ATTACHED WITH (2) 1/4" x 3/4" SELF TAPPING SCREWS. NOTE THAT LHR BRACKETS ARE ALSO USED WITH "DOUBLE END STILE" AS NOTED ON SHEET 2.

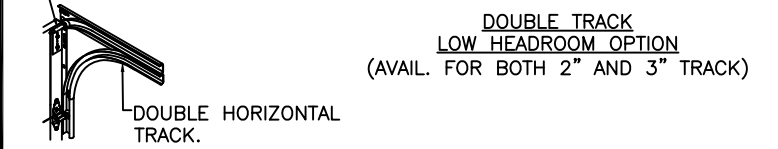

3" TRACK CONFIGURATION
DOORS 800 LBS AND OVER.

NOTE DOUBLE TRACK HEADROOM, HI-LIFT TRACK, FOLLOW-THE-ROOF TRACK, AND VERTICAL LIFT TRACK ARE AVAILABLE OPTIONS. TRACK CONFIGURATION ABOVE THE DOOR OPENING DOES NOT AFFECT THE WIND LOAD RATING.

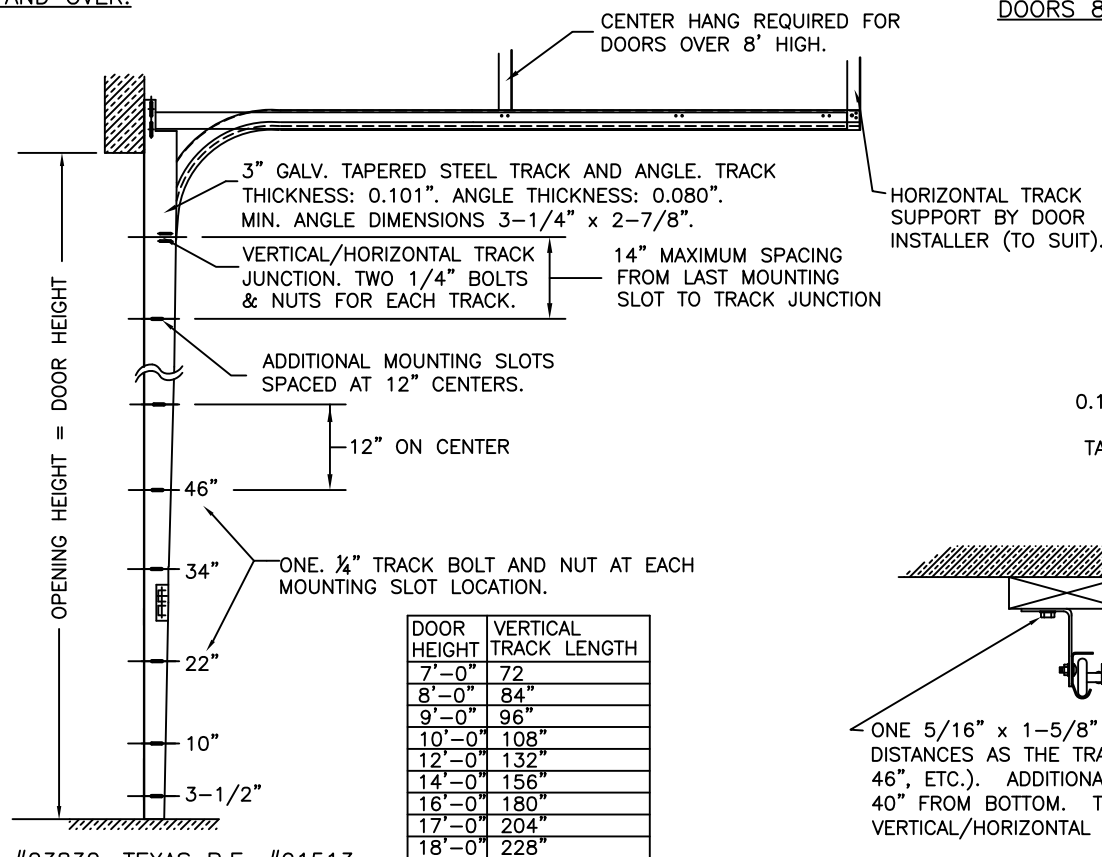

DOOR HEIGHT	VERTICAL TRACK LENGTH
7'-0"	72"
8'-0"	84"
9'-0"	96"
10'-0"	108"
12'-0"	132"
14'-0"	156"
16'-0"	180"
17'-0"	204"
18'-0"	228"

JAMB CONFIGURATION
DOORS 800 LBS AND OVER.

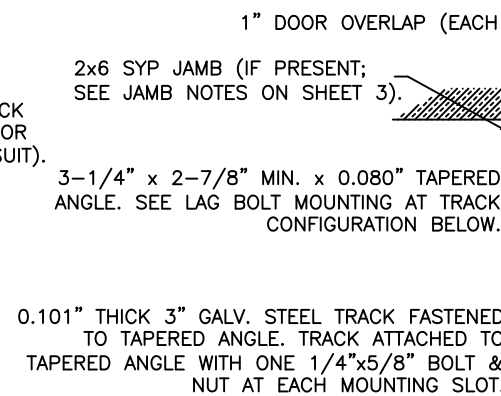

SECTION C-C

PREPARATION OF JAMBS BY OTHERS.

DESIGN LOADS: +52.0 P.S.F. & -58.0 P.S.F.
TEST LOADS: +78.0 P.S.F. & -87.0 P.S.F.

Unless Stated Otherwise TOLERANCES are
.0 = ±.031
.00 = ±.015
.000 = ±.005
.0000 = ±.001
Degrees = ±1/2"

Unless Stated Otherwise DIMENSIONS ARE IN INCHES.

Clopay
Building Products Company

8585 Duke Boulevard
Mason, OH 45040 USA
Tel. No. 513-770-4800
Fax No. 513-770-4853

MANUFACTURING PRODUCT CODE
C-PAN-1E448

PART NO.: N/A

WINDLOAD RATING
W8 DP52T

DESCRIPTION: COMMERCIAL RIBBED DOORS UP TO 12'2"W (SEE TABLE)

DRAWN BY: SH DATE: 1/10/13 SCALE: NTS DWG. B

CHECKED BY: SH DATE: 1/10/13 SHEET 3 OF 3 SIZE B

DWG. NO.: 104813 VER: TDI

DESIGN ENGINEER:
MARK WESTERFIELD, P.E.
FLORIDA P.E. #48495, NC P.E. #23832, TEXAS P.E. #91513