

CLOPAY / IDEAL / HOLMES  
 3717 / C7X17 / -- / 27GA 1.75" THICK MINDR RIB  
 3718 / C7X18 / -- / 27GA 1.75" THICK FLUSH  
 3720 / C7X20 / 240U / 27GA 2" THICK MINDR RIB  
 3722 / C0X22 / -- / 20GA 2" THICK FLUSH  
 3724 / C7X24 / 244U / 24GA 2" THICK MINDR RIB

SHEET:  
 1 OF 4

REVISIONS					
REV. NO.	ZONE:	DATE:	ECN NO.	APPVD:	DESCRIPTION
01	-	3/7/14	-	SH	CORRECTED TYPO ON ELEVATION VIEW.
02	-	05/13/14	-	RJK	NEW IMPACT WINDOW CROSS SECTION SHEET 2.
03	-	03/04/15	-	RJK	CORRECTED FOR 3 CENTER STILES AND FOUR WINDOWS.
04	-	4/15/15	-	SH	ADDED WIND SPEED TABLE.

OPTIONAL GLAZING SHALL BE IMPACT RESISTANT GLAZING. MAXIMUM GLAZING SIZE (DLO) IS 22"x9-7/8". SEE SECTION B-B ON SHEET 2 FOR DETAILS.  
 GLAZING MAY BE INSTALLED IN TOP SECTION (NOT SHOWN) OR INTERMEDIATE SECTION (SHOWN).

(1) 20 GA. GALV. STEEL BACKER PLATE AT EACH INTERMEDIATE HINGE LOCATION. BACKER PLATE ATTACHED WITH DOUBLE SIDED ACRYLIC TAPE TO BACK OF DOOR.

16 GA. DOUBLE END STILE

T-STRUTS SHOWN WITH GLAZING IN TOP SECTION.

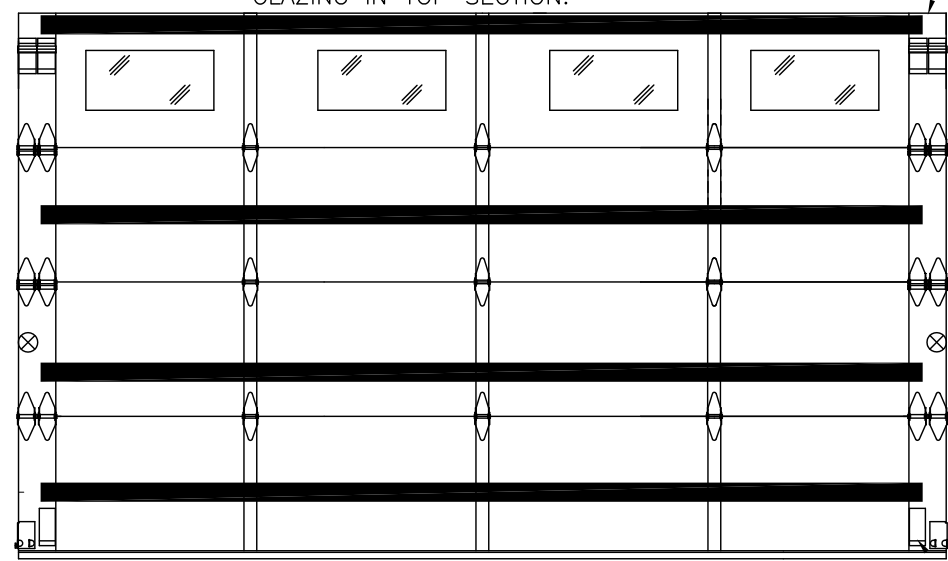
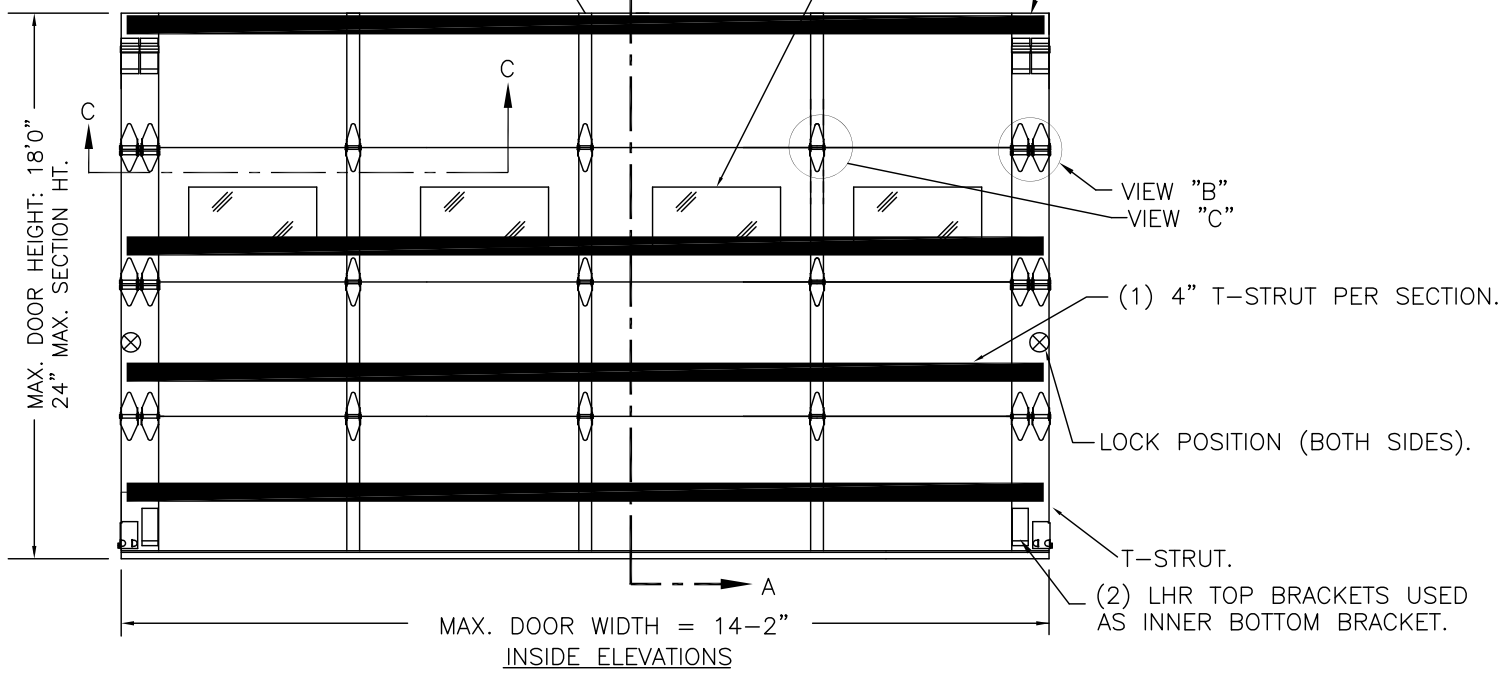

DOOR HEIGHT 'A'	NUMBER OF SECTIONS
UP TO 8'-0"	4
8'-3" THRU 10'-0"	5
10'-3" THRU 12'-0"	6
12'-3" THRU 14'-0"	7
14'-3" THRU 16'-0"	8
16'-3" THRU 18'-0"	9

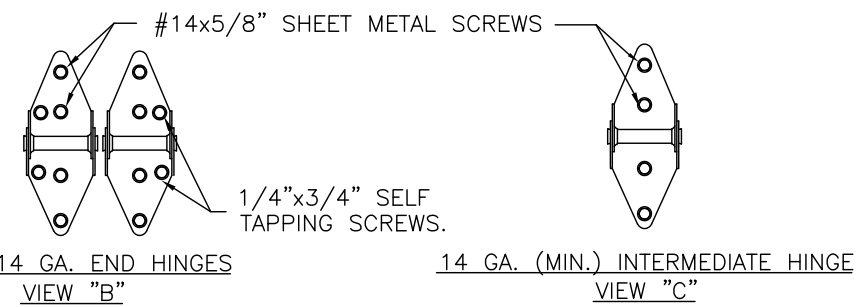

THIS DOOR MEETS OR EXCEEDS THE DESIGN LOADS FOR THE ULTIMATE WIND SPEEDS LISTED BELOW ACCORDING TO THE FLORIDA BUILDING CODE OR THE INTERNATIONAL BUILDING CODE (BASED ON ASCE7-10) FOR THE FOLLOWING CONDITIONS: 1) ENCLOSED BUILDING, 2) DOOR HAS 2' OF WIDTH IN BUILDING'S END ZONE, 3) ANY ROOF SLOPE, AND 4) TESTING IN ACCORDANCE WITH ANSI/DASMA 108. SITE-SPECIFIC CALCULATIONS BY A QUALIFIED DESIGN PROFESSIONAL MAY DIFFER.

ULTIMATE WIND SPEED (MPH)	185	195	200	200	200
EXPOSURE CATEGORY	B, C, D	B, C, D	B, C	B, C	B
MEAN ROOF HEIGHT	25'	15'	25'	15'	30'

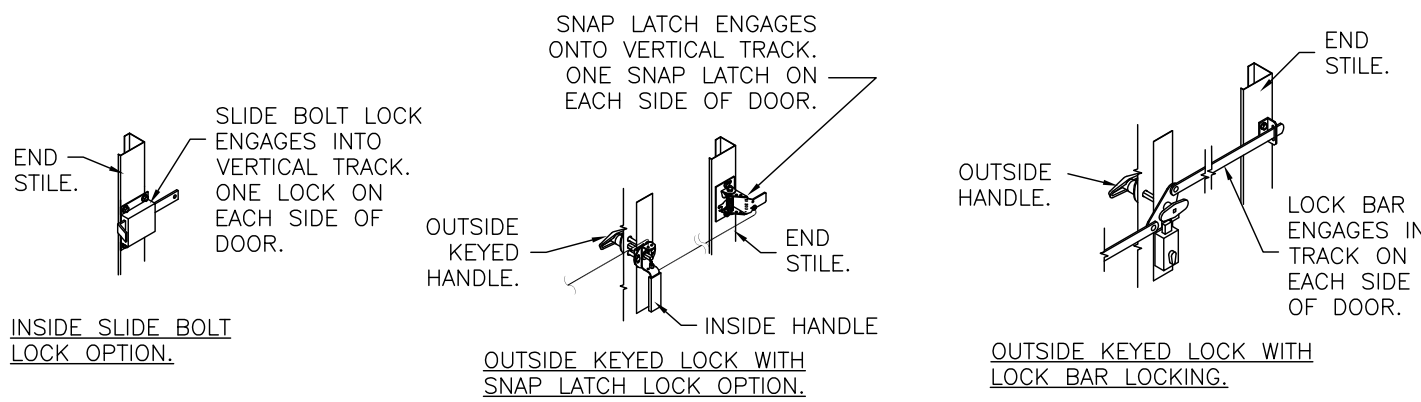
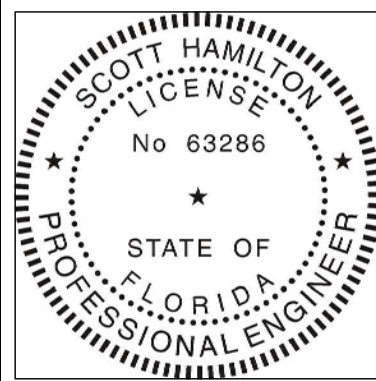

DESIGN LOADS: +52.0 P.S.F. & -58.0 P.S.F.  
 TEST LOADS: +78.0 P.S.F. & -87.0 P.S.F.

Unless Stated Otherwise TOLERANCES are  
 .0 = ±.031  
 .00 = ±.015  
 .000 = ±.005  
 .0000 = ±.001  
 Degrees = ±1/2"



8585 Duke Boulevard  
 Mason, OH 45040 USA  
 Tel. No. 513-770-4800  
 Fax No. 513-770-4853

MANUFACTURING PRODUCT CODE  
 C-DSIU-1D477

PART NO.: N/A

WINDLOAD RATING  
 W8 DP52T

DESCRIPTION: 1-3/4" INTELLICORE DOORS UP TO 14'2"W (SEE TABLE)			
DRAWN BY: SH	DATE: 4/7/14	SCALE: NTS	DWG. SIZE B
CHECKED BY: SH	DATE: 4/7/14	SHEET 1 OF 4	
DWG. NO.: 104842	VER: IBC		

DESIGN ENGINEER:  
 SCOTT HAMILTON, P.E.  
 FLORIDA LICENSE No. 63286

CLOPAY / IDEAL / HOLMES  
 3717 / C7X17 / -- / 27GA 1.75" THICK MINDR RIB  
 3718 / C7X18 / -- / 27GA 1.75" THICK FLUSH  
 3720 / C7X20 / 240U / 27GA 2" THICK MINDR RIB  
 3722 / COX22 / -- / 20GA 2" THICK FLUSH  
 3724 / C7X24 / 244U / 24GA 2" THICK MINDR RIB

SHEET:  
 2 OF 4

REVISIONS					DESCRIPTION
REV. NO.	ZONE:	DATE:	ECN NO.	APPVD:	
	-	-	-	SH	SEE REVISION HISTORY ON SHEET ONE.

**IMPACT-RESISTANT CONSTRUCTION:**  
 SOLID DOORS (NO GLAZING) OR DOORS WITH OPTIONAL IMPACT-RESISTANT GLAZING ARE IMPACT-RESISTANT. OPTIONAL IMPACT RESISTANT ASSEMBLY CONSISTS OF ALUMINUM FRONT FRAME AND SABIC IP LEXAN 9034 (VERSIONS ALSO APPROVED: MR10, 9030, 90318, 90316, 90317, 90311, 90314, 90355) OR BAYER MAKROLON GP (VERSIONS ALSO APPROVED: SL, AR, 15), APPROVED CC1 PLASTICS IN ACCORDANCE WITH IBC/FBC 2606 AND APPROVED C1 PLASTICS IN ACCORDANCE WITH FBC 2612. THE ENTIRE DOOR ASSEMBLY INSTALLED IN COMPLIANCE WITH THIS SECTION MEETS THE WIND LOAD REQUIREMENTS OF THE FLORIDA BUILDING CODE AND INTERNATIONAL BUILDING CODE AND IS LARGE- AND SMALL-MISSILE IMPACT RESISTANT.

SECTION B-B (IMPACT-RESISTANT GLAZING OPTION)

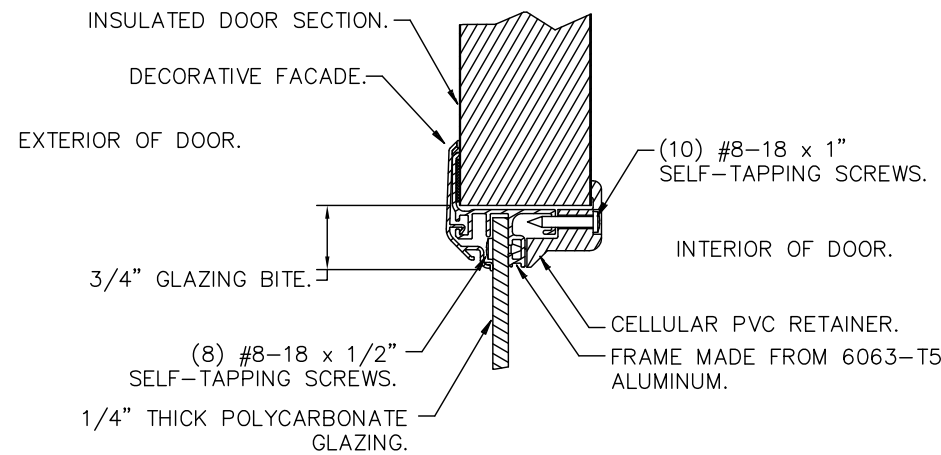

IMPACT-RESISTANT GLAZING DETAILS

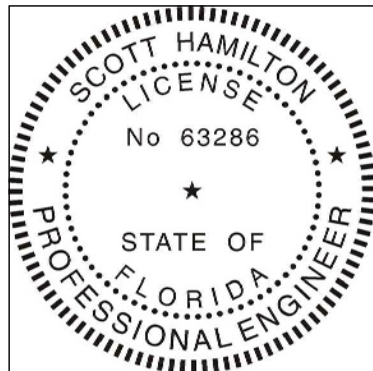

DESIGN ENGINEER:  
 SCOTT HAMILTON, P.E.  
 FLORIDA LICENSE No. 63286

DESIGN LOADS: +52.0 P.S.F. & -58.0 P.S.F.  
 TEST LOADS: +78.0 P.S.F. & -87.0 P.S.F.

Unless Stated Otherwise  
 TOLERANCES are  
 .0 = ±.031  
 .00 = ±.015  
 .000 = ±.005  
 .0000 = ±.001  
 Degrees = ±1/2"

Unless Stated Otherwise  
 DIMENSIONS ARE IN INCHES.

**Glopay**  
 Building Products Company  
 8585 Duke Boulevard  
 Mason, OH 45040 USA  
 Tel. No. 513-770-4800  
 Fax No. 513-770-4853

MANUFACTURING PRODUCT CODE  
 C-DSIU-1D477

PART NO.: N/A

WINDLOAD RATING  
 W8 DP52T

DESCRIPTION: 1-3/4" INTELLICORE DOORS UP TO 14'2"W (SEE TABLE)

DRAWN BY: SH DATE: 4/7/14 SCALE: NTS DWG. B

CHECKED BY: SH DATE: 4/7/14 SHEET 2 OF 4 SIZE B

DWG. NO.: 104842 VER: IBC

CLOPAY / IDEAL / HOLMES
3717 / C7X17 / -- / 27GA 1.75" THICK MINDR RIB
3718 / C7X18 / -- / 27GA 1.75" THICK FLUSH
3720 / C7X20 / 240U / 27GA 2" THICK MINDR RIB
3722 / COX22 / -- / 20GA 2" THICK FLUSH
3724 / C7X24 / 244U / 24GA 2" THICK MINDR RIB

SHEET:  
3 OF 4

REVISIONS					
REV. NO.	ZONE:	DATE:	ECN NO.	APPVD:	DESCRIPTION
	-	-	-	SH	SEE REVISION HISTORY ON SHEET ONE.

D

C

B

A

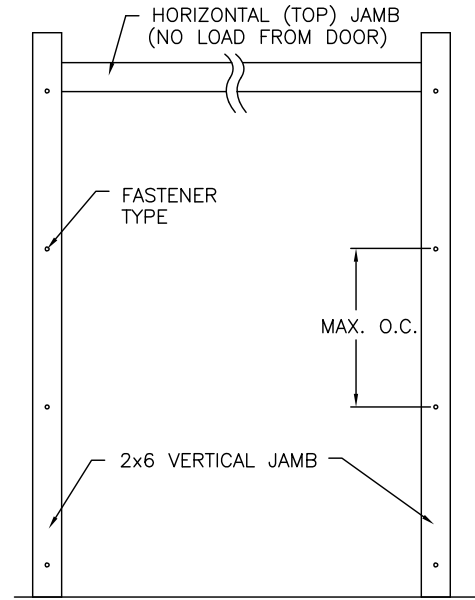

JAMB TO SUPPORTING STRUCTURE ATTACHMENT

- NOTES:
1. ALL THE LOAD FROM THE DOOR IS TRANSFERRED TO THE TRACK AND THEN FROM THE TRACK TO THE 2x6 VERTICAL SYP (GRADE #2 OR BETTER) JAMBS. NO LOAD FROM THE DOOR IS TRANSFERRED TO THE HORIZONTAL (TOP) JAMB.
  2. EACH VERTICAL JAMB SEES A MAXIMUM DESIGN LOAD OF +364 LB & -406 LB. PER LINEAR FOOT OF JAMB.
  3. ALL JAMB FASTENERS MAY BE (BUT ARE NOT REQUIRED TO BE) COUNTERSUNK TO PROVIDE A FLUSH MOUNTING SURFACE.
  4. A 1/3 STRESS INCREASE FOR WIND LOAD WAS NOT USED IN THE CALCULATION OF ALLOWABLE LOADS FOR ANCHORS AND FASTENERS FOR STEEL, CONCRETE AND MASONRY.

NOTE: 2x6 WOOD JAMBS ARE NOT REQUIRED WITH CONTINUOUS ANGLE MOUNT TRACK. HOWEVER, IF DESIRED ON STEEL JAMBS OR CONCRETE OR BLOCK WALLS, APPROVED FASTENERS AS DETAILED BELOW SHOULD BE INCREASED IN LENGTH BY 1-1/2" AND INSTALLED DIRECTLY THROUGH THE ANGLE AND 2x6 WOOD JAMBS INTO THE STEEL JAMBS OR CONCRETE OR BLOCK WALLS. ANCHORS CAN BE (BUT ARE NOT REQUIRED TO BE) COUNTERSUNK TO PROVIDE A FLUSH MOUNTING SURFACE. CONTINUOUS ANGLE TRACK CAN BE ANCHORED DIRECTLY TO GROUT REINFORCED BLOCK WALL OR 3,000 PSI MIN. CONCRETE COLUMN OR STEEL JAMBS.

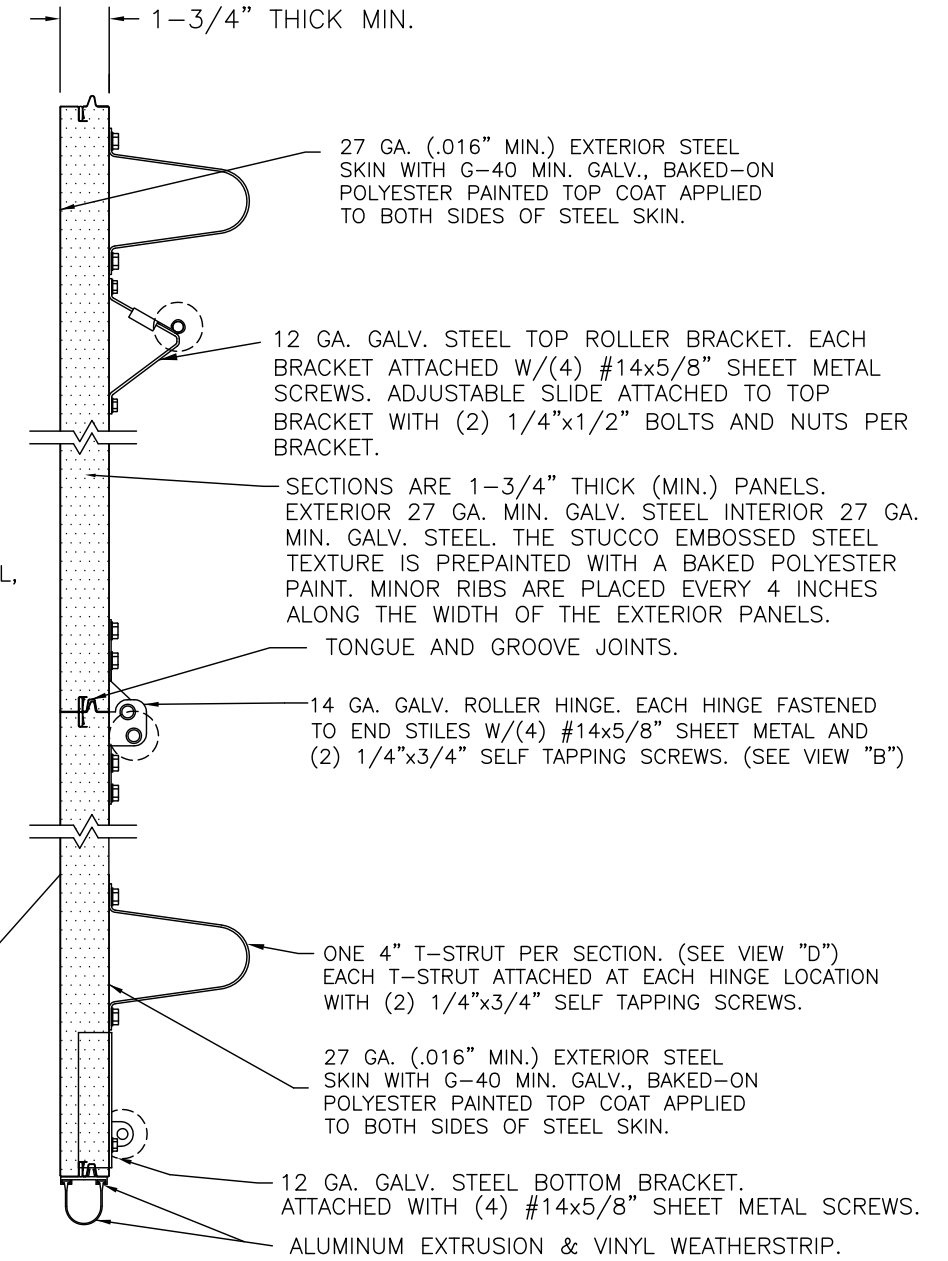
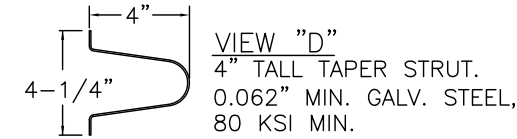

SECTION A-A (SIDE VIEW)

FASTENER ATTACHMENT TO SUPPORTING STRUCTURE SCHEDULES

BUILDING TYPE	FASTENER TYPE	MAXIMUM ON-CENTER DISTANCE BETWEEN FASTENERS*	STEEL WASHERS REQUIRED?
HOLLOW BLOCK WALL	1/4" x 1-1/4" MIN. EMBED ULTRACON CONCRETE ANCHOR	4-1/2"	1" O.D.
GROUT FILLED BLOCK WALL	1/4" x 1-3/4" MIN. EMBED ULTRACON CONCRETE ANCHOR	7-1/2"	1" O.D.
2000 PSI MIN. CONCRETE	1/4" x 1" MIN. EMBED ULTRACON CONCRETE ANCHOR	6-1/2"	1" O.D.
2000 PSI MIN. CONCRETE	1/4" x 1" MIN. EMBED TAPCON CONCRETE ANCHOR	5-1/4"	1" O.D.
2000 PSI MIN. CONCRETE	3/8" x 1-3/4" MIN. EMBED WEJ-IT ANKR TITE SLEEVE ANCHOR	13-3/4"	INCLUDED
4000 PSI MIN. CONCRETE	3/8" x 1-3/4" MIN. EMBED WEJ-IT ANKR TITE SLEEVE ANCHOR	24"	INCLUDED
WOOD FRAME (SYP 0.55 SG)	1/2" x 3" LAG SCREW (ASTM A307, GRADE A) 1-5/8" EMBED INTO STRUCTURE	15"	1" O.D.
14GA STEEL (0.060" MIN.)	1/4"-14 x 1" ITW BUILDEX TEKS SELF-DRILLING FASTENER	6"	1" O.D.
12GA STEEL (0.105" MIN.)	1/4"-14 x 1" ITW BUILDEX TEKS SELF-DRILLING FASTENER	11"	1" O.D.
1/8" STEEL	1/4"-14 x 1" ITW BUILDEX TEKS SELF-DRILLING FASTENER	13"	1" O.D.

\* FIRST (BOTTOM) ANCHOR STARTING AT NO MORE THAN HALF OF THE MAXIMUM ON-CENTER DISTANCE. HIGHEST ANCHOR INSTALLED AT LEAST AS HIGH AS THE DOOR OPENING.  
CLOPAY DOES NOT SUPPLY JAMB ATTACHMENT FASTENERS.  
MINIMUM DISTANCE BETWEEN CENTER OF ANCHOR AND EDGE OF CONCRETE BLOCK: 2-1/2", EXCLUDING STUCCO THICKNESS.

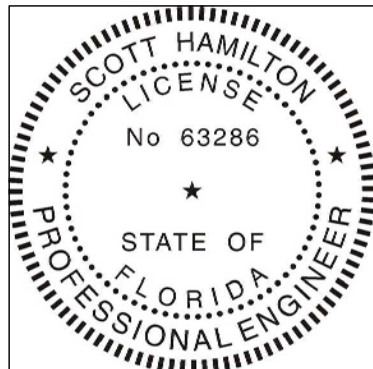

DESIGN ENGINEER:  
SCOTT HAMILTON, P.E.  
FLORIDA LICENSE No. 63286

DESIGN LOADS: +52.0 P.S.F. & -58.0 P.S.F.  
TEST LOADS: +78.0 P.S.F. & -87.0 P.S.F.

Unless Stated Otherwise  
TOLERANCES are  
.0 = ±.031  
.00 = ±.015  
.000 = ±.005  
.0000 = ±.001  
Degrees = ±1/2"  
Unless Stated Otherwise  
DIMENSIONS ARE IN INCHES.



8585 Duke Boulevard  
Mason, OH 45040 USA  
Tel. No. 513-770-4800  
Fax No. 513-770-4853

MANUFACTURING PRODUCT CODE  
C-DSIU-1D477

PART NO.: N/A

WINDLOAD RATING  
W8 DP52T

DESCRIPTION: 1-3/4" INTELLICORE DOORS UP TO 14'2"W (SEE TABLE)

DRAWN BY: SH DATE: 4/7/14 SCALE: NTS DWG. B

CHECKED BY: SH DATE: 4/7/14 SHEET 3 OF 4 SIZE B

DWG. NO.: 104842 VER: IBC

4

3

2

1

CLOPAY / IDEAL / HOLMES
3717 / C7X17 / -- / 27GA 1.75" THICK MINDR RIB
3718 / C7X18 / -- / 27GA 1.75" THICK FLUSH
3720 / C7X20 / 240U / 27GA 2" THICK MINDR RIB
3722 / C0X22 / -- / 20GA 2" THICK FLUSH
3724 / C7X24 / 244U / 24GA 2" THICK MINDR RIB

SHEET:  
4 OF 4

REVISIONS					DESCRIPTION
REV. NO.	ZONE:	DATE:	ECN NO.	APPVD:	
-	-	-	-	SH	SEE REVISION HISTORY ON SHEET ONE.

**2" TRACK CONFIGURATION.**

NOTE DOUBLE TRACK HEADROOM, HI-LIFT TRACK, FOLLOW-THE-ROOF TRACK, AND VERTICAL LIFT TRACK ARE AVAILABLE OPTIONS. TRACK CONFIGURATION ABOVE THE DOOR OPENING DOES NOT AFFECT THE WIND LOAD RATING.

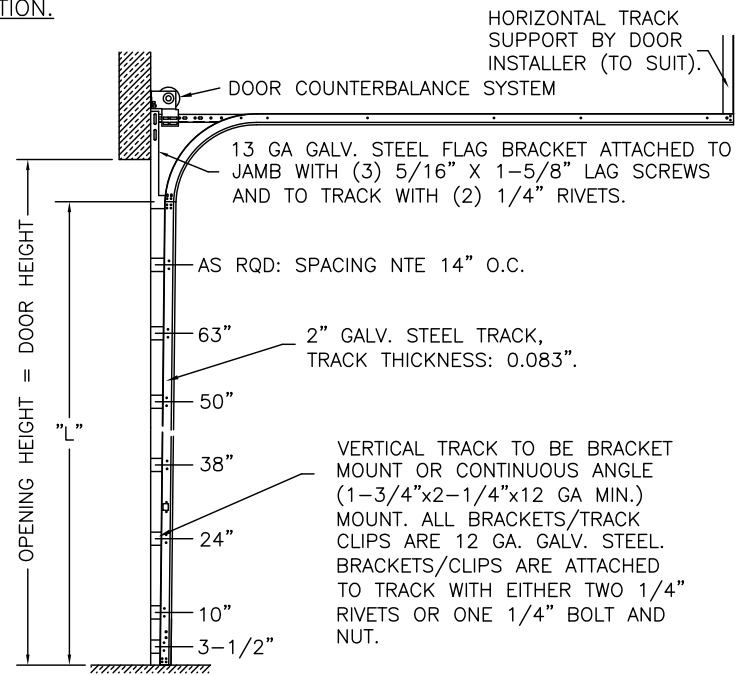

DOOR HEIGHT	"L"
6'-6"	70"
7'-0"	76"
7'-6"	82"
8'-0"	88"
8'-6"	94"
9'-0"	100"
9'-6"	106"
10'-0"	112"
10'-6"	118"
11'-0"	124"
11'-6"	130"
12'-0"	136"
12'-6"	142"
13'-0"	148"
13'-6"	154"
14'-0"	160"
14'-6"	166"
15'-0"	172"
15'-6"	178"
16'-0"	184"
16'-6"	190"
17'-0"	196"
17'-6"	202"
18'-0"	208"

**JAMB CONFIGURATION FOR 2" TRACK.**

**BRACKET MOUNT JAMB CONFIGURATION**

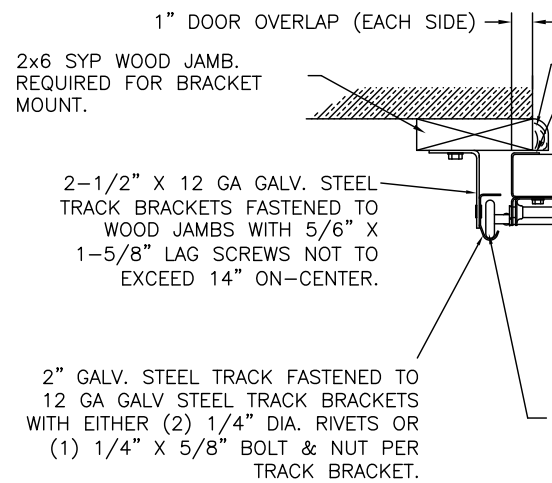

**ANGLE MOUNT JAMB CONFIGURATION**

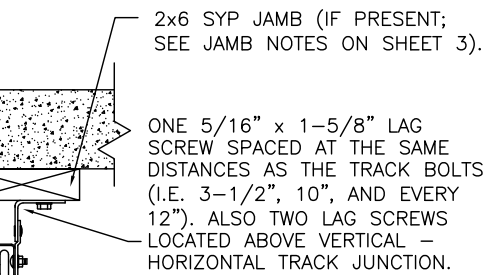

**SECTION C-C**

**PREPARATION OF JAMBS BY OTHERS.**

LHR BRACKET (2-1/2" x 5-3/4" x 12GA) ATTACHED WITH (2) 1/4" x 3/4" SELF TAPPING SCREWS. NOTE THAT LHR BRACKETS ARE ALSO USED WITH "DOUBLE END STILE" AS SHOWN IN ZONE B-3 SHEET 1.

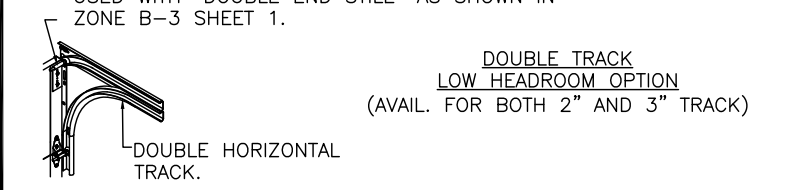

**3" TRACK CONFIGURATION.**

NOTE DOUBLE TRACK HEADROOM, HI-LIFT TRACK, FOLLOW-THE-ROOF TRACK, AND VERTICAL LIFT TRACK ARE AVAILABLE OPTIONS. TRACK CONFIGURATION ABOVE THE DOOR OPENING DOES NOT AFFECT THE WIND LOAD RATING.

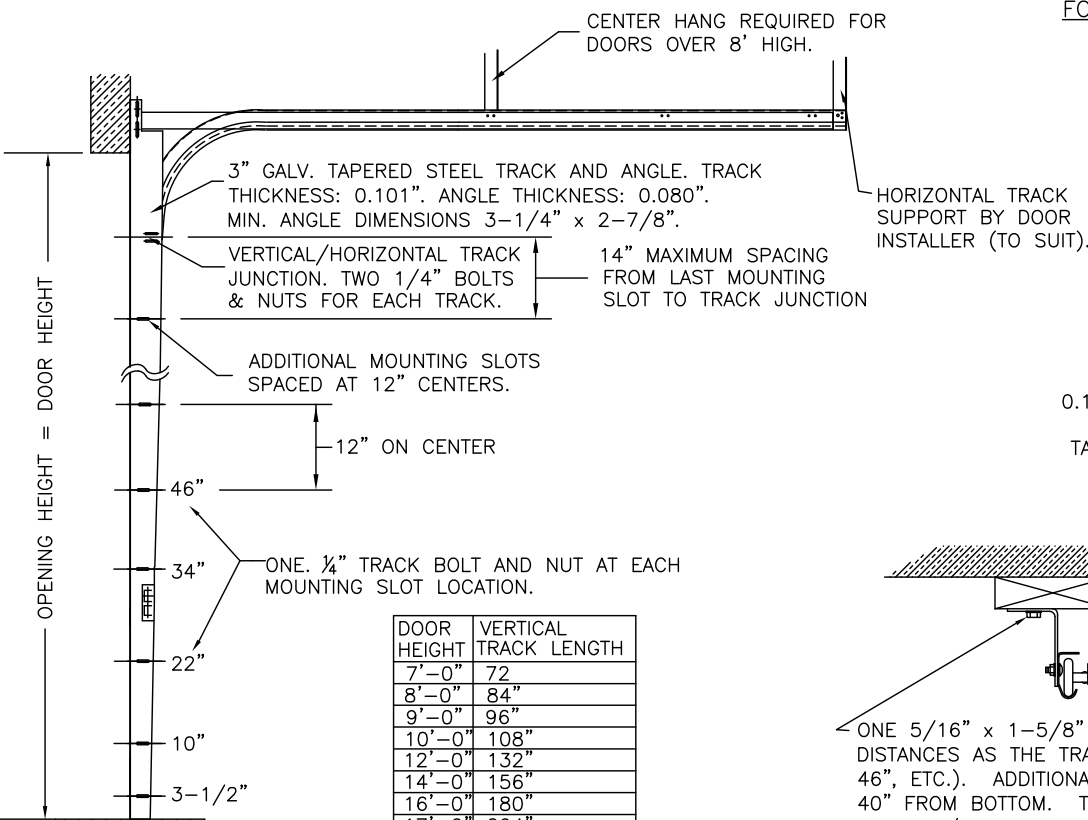

DOOR HEIGHT	VERTICAL TRACK LENGTH
7'-0"	72"
8'-0"	84"
9'-0"	96"
10'-0"	108"
12'-0"	132"
14'-0"	156"
16'-0"	180"
17'-0"	204"
18'-0"	228"

**JAMB CONFIGURATION FOR 3" TRACK.**

**BRACKET MOUNT JAMB CONFIGURATION**

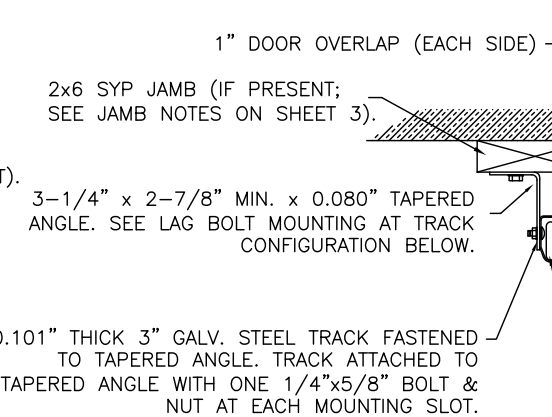

**SECTION C-C**

**PREPARATION OF JAMBS BY OTHERS.**

DESIGN LOADS: +52.0 P.S.F. & -58.0 P.S.F.  
TEST LOADS: +78.0 P.S.F. & -87.0 P.S.F.

Unless Stated Otherwise TOLERANCES are  
.0 = ±.031  
.00 = ±.015  
.000 = ±.005  
.0000 = ±.001  
Degrees = ±1/2"

Unless Stated Otherwise DIMENSIONS ARE IN INCHES.

**Glopay**  
Building Products Company  
8585 Duke Boulevard  
Mason, OH 45040 USA  
Tel. No. 513-770-4800  
Fax No. 513-770-4853

MANUFACTURING PRODUCT CODE  
C-DSIU-1D477

PART NO.: N/A

WINDLOAD RATING  
W8 DP52T

DESCRIPTION: 1-3/4" INTELLICORE DOORS UP TO 14'2"W (SEE TABLE)

DRAWN BY: SH DATE: 4/7/14 SCALE: NTS DWG. B

CHECKED BY: SH DATE: 4/7/14 SHEET 4 OF 4 SIZE B

DWG. NO.: 104842 VER: IBC

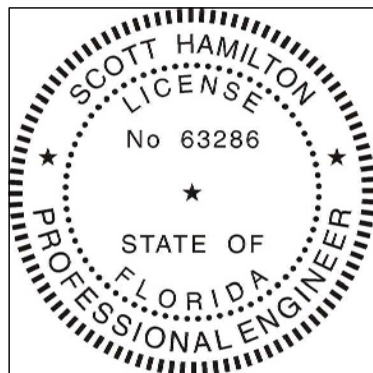

DESIGN ENGINEER:  
SCOTT HAMILTON, P.E.  
FLORIDA LICENSE No. 63286