

CLOPAY / IDEAL / HOLMES
 3717 / C7X17 / -- / 27GA 1.75" THICK MINOR RIB
 3718 / C7X18 / -- / 27GA 1.75" THICK FLUSH
 3720 / C7X20 / 240U / 27GA 2" THICK MINOR RIB
 3722 / C0X22 / -- / 20GA 2" THICK FLUSH
 3724 / C7X24 / 244U / 24GA 2" THICK MINOR RIB

SHEET:
1 OF 2

REVISIONS					
REV. NO.	ZONE:	DATE:	ECN NO.	APPVD:	DESCRIPTION
00	-	1/12/15	-	S.H.	INITIAL RELEASE
01	-	4/15/15	-	SH	REVISED FOR RELEASE.

MAX. 14'-2" WIDE X 18'-0" HIGH

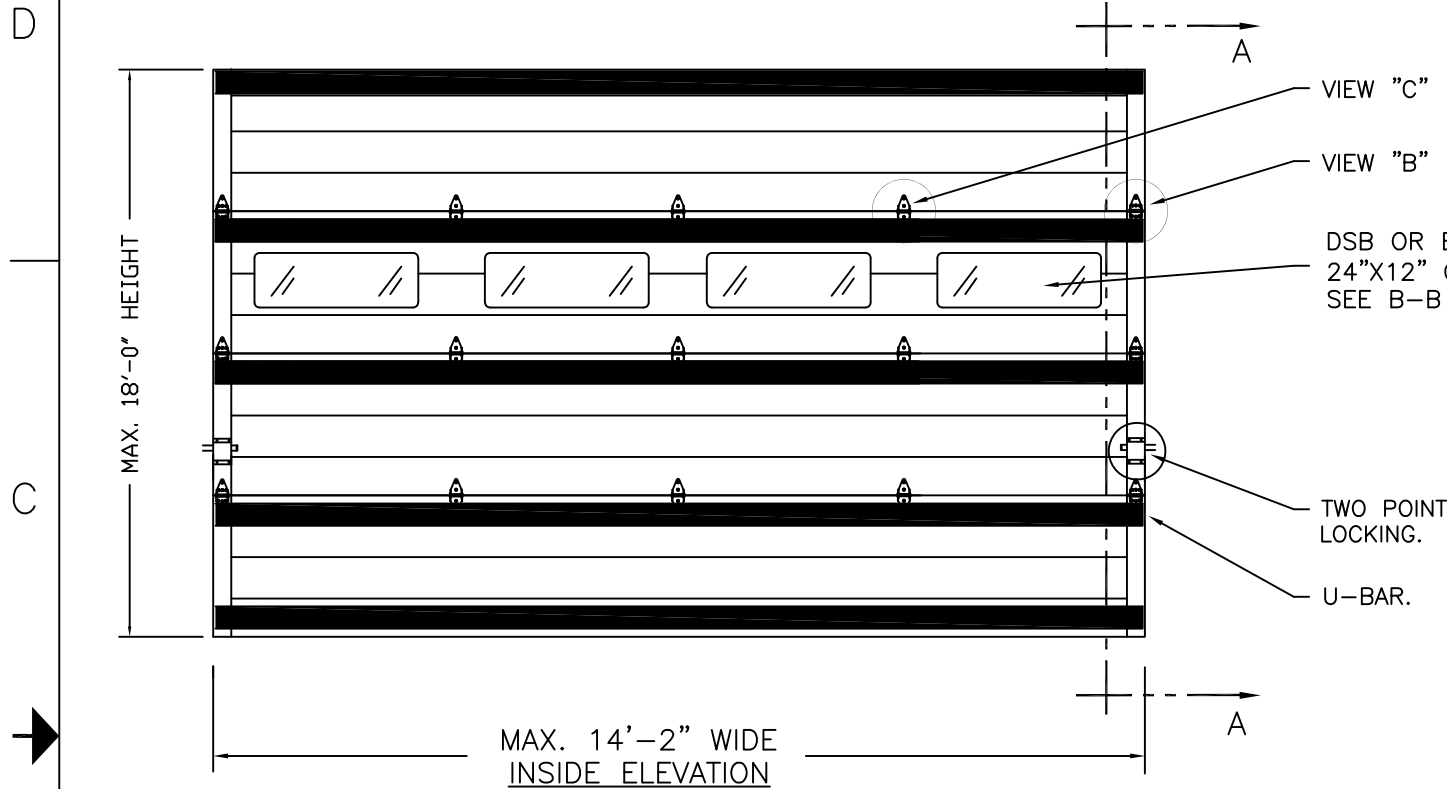

DSB OR BETTER 24"x8" AND 24"x12" GLAZING IS AVAILABLE. SEE B-B FOR DETAILS.

TWO POINT LOCKING.
U-BAR.

MAX. 14'-2" WIDE INSIDE ELEVATION

DOOR HEIGHT 'A'	NUMBER OF SECTIONS
UP TO 8'-0"	4
8'-3" THRU 10'-0"	5
10'-3" THRU 12'-0"	6
12'-3" THRU 14'-0"	7
14'-3" THRU 16'-0"	8
16'-3" THRU 18'-0"	9

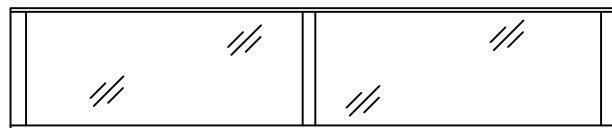

OPTIONAL ALUMINUM FULL VISION WINDOW LITE SECTIONS AVAILABLE (1/8" DSB, 1/8" ACRYLIC, 1/4" WIRE, 1/2" INSUL.). FULL VISION SECTIONS TO HAVE SAME REINFORCEMENT AS OTHER SECTIONS. OPTIONAL ACRYLIC IS PLASKOLITE OPTIX, AN APPROVED CC2 PLASTIC IN COMPLIANCE WITH IBC/FBC 2606.

SECTION B-B (STANDARD GLAZING OPTION)

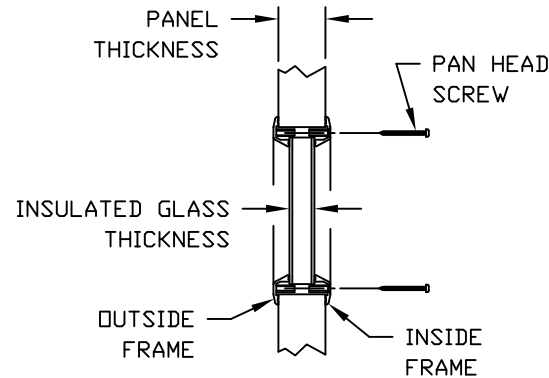

SECTION A-A (SIDE VIEW)

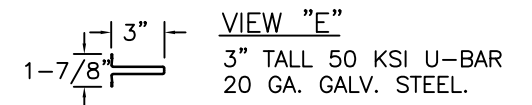
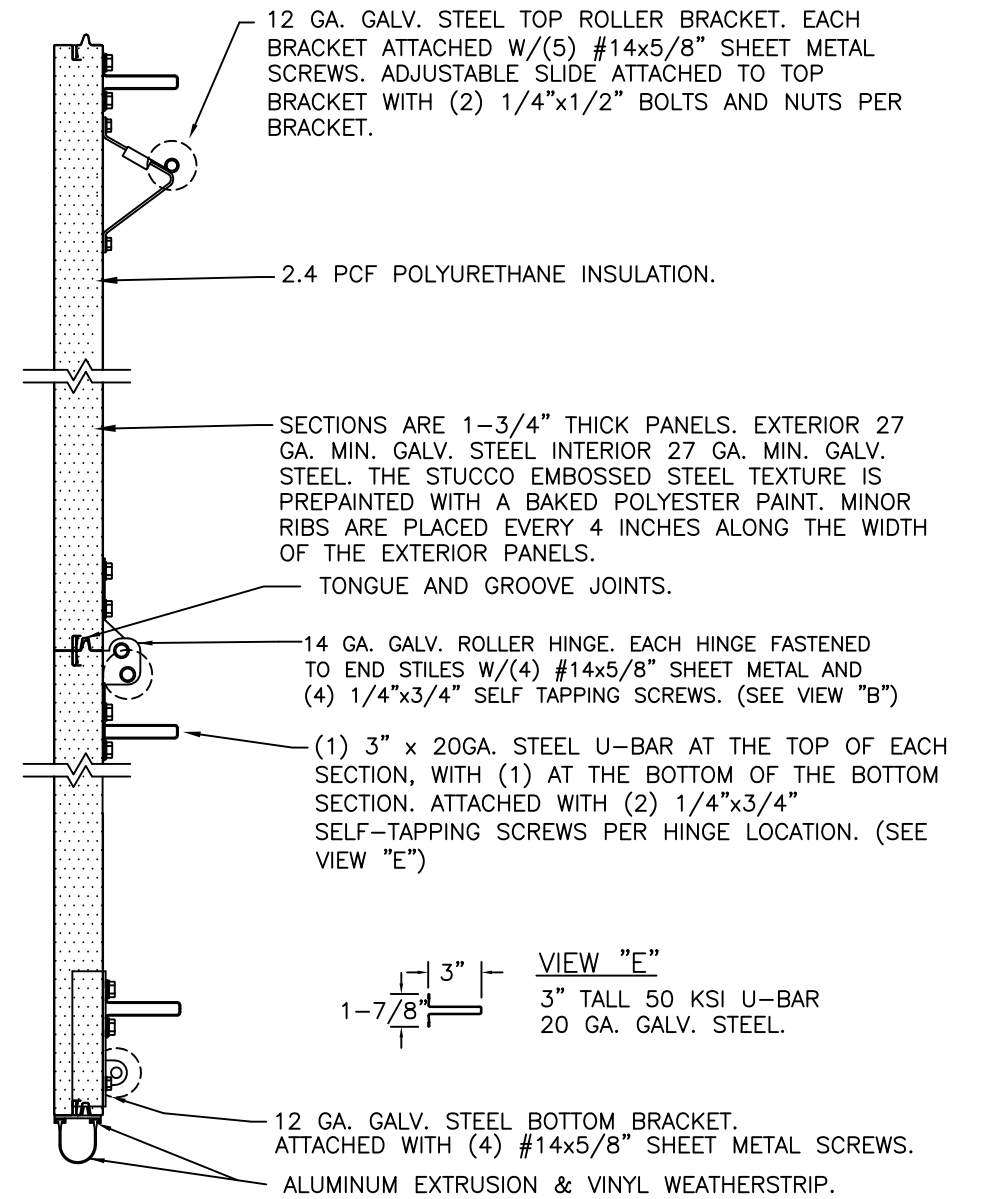

THIS DOOR MEETS OR EXCEEDS THE DESIGN LOADS FOR THE ULTIMATE WIND SPEEDS LISTED BELOW ACCORDING TO THE FLORIDA BUILDING CODE OR THE INTERNATIONAL BUILDING CODE (BASED ON ASCE7-10) FOR THE FOLLOWING CONDITIONS: 1) ENCLOSED BUILDING, 2) DOOR HAS 2' OF WIDTH IN BUILDING'S END ZONE, 3) ANY ROOF SLOPE, AND 4) TESTING IN ACCORDANCE WITH ANSI/DASMA 108. SITE-SPECIFIC CALCULATIONS BY A QUALIFIED DESIGN PROFESSIONAL MAY DIFFER.

ULTIMATE WIND SPEED (MPH)	120	125	135	140	155
EXPOSURE CATEGORY	B, C, D	B, C, D	B, C	B, C	B
MEAN ROOF HEIGHT	25'	15'	25'	15'	30'

DESIGN LOADS: +25.0 P.S.F. & -25.0 P.S.F.
TEST LOADS: +37.5 P.S.F. & -37.5 P.S.F.

Unless Stated Otherwise TOLERANCES are
 .0 = ±.031
 .00 = ±.015
 .000 = ±.005
 .0000 = ±.001
 Degrees = ±1/2"

Unless Stated Otherwise DIMENSIONS ARE IN INCHES.

Glopay
Building Products Company

8585 Duke Boulevard
Mason, OH 45040 USA
Tel. No. 513-770-4800
Fax No. 513-770-4853

MANUFACTURING PRODUCT CODE
C-DSIU-1D477
PART NO.: N/A

WINDLOAD RATING
W4 DP25

DESCRIPTION: 1-3/4" INTELLICORE DOORS UP TO 14'2"W (SEE TABLE)

DRAWN BY: S.H. DATE: 8/18/14 SCALE: NTS DWG. B

CHECKED BY: S.H. DATE: 8/18/14 SHEET 1 OF 2 SIZE B

DWG. NO.: 104956 VER: IBC

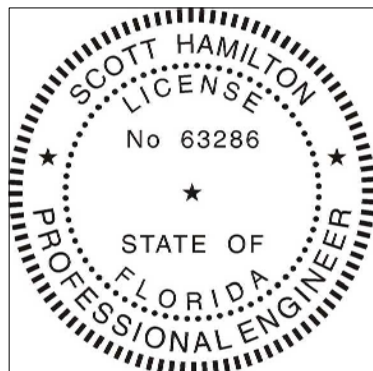

DESIGN ENGINEER:
SCOTT HAMILTON, P.E.
FLORIDA LICENSE No. 63286

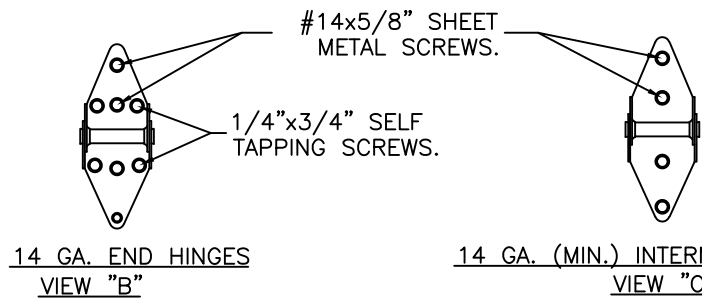

14 GA. END HINGES
VIEW "B"

14 GA. (MIN.) INTERMEDIATE HINGE
VIEW "C"

CLOPAY / IDEAL / HOLMES
 3717 / C7X17 / -- / 27GA 1.75" THICK MINOR RIB
 3718 / C7X18 / -- / 27GA 1.75" THICK FLUSH
 3720 / C7X20 / 240U / 27GA 2" THICK MINOR RIB
 3722 / COX22 / -- / 20GA 2" THICK FLUSH
 3724 / C7X24 / 244U / 24GA 2" THICK MINOR RIB

SHEET:
2 OF 2

REVISIONS					
REV. NO.	ZONE:	DATE:	ECN NO.	APPVD:	DESCRIPTION
00	-	-	-	-	SEE REVISION HISTORY ON SHEET ONE.

2" TRACK CONFIGURATION.

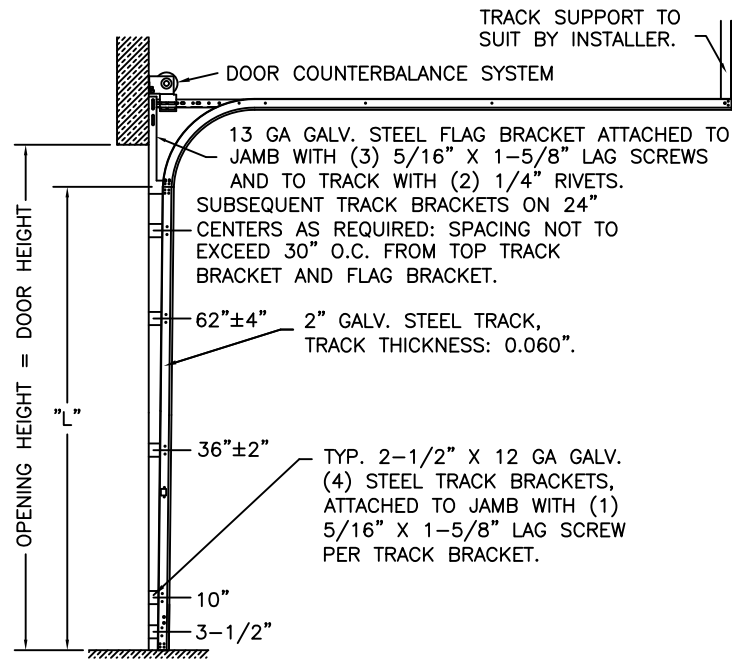

DOOR HEIGHT	"L"
6'-6"	70"
7'-0"	76"
7'-6"	82"
8'-0"	88"
8'-6"	94"
9'-0"	100"
9'-6"	106"
10'-0"	112"
10'-6"	118"
11'-0"	124"
11'-6"	130"
12'-0"	136"
12'-6"	142"
13'-0"	148"
13'-6"	154"
14'-0"	160"
14'-6"	166"
15'-0"	172"
15'-6"	178"
16'-0"	184"
16'-6"	190"
17'-0"	196"
17'-6"	202"
18'-0"	208"

NOTE 3" TRACK, DOUBLE TRACK HEADROOM, HI-LIFT TRACK, FOLLOW-THE-ROOF TRACK, AND VERTICAL LIFT TRACK ARE AVAILABLE OPTIONS. TRACK CONFIGURATION ABOVE THE DOOR OPENING DOES NOT AFFECT THE WIND LOAD RATING.

JAMB CONFIGURATION.

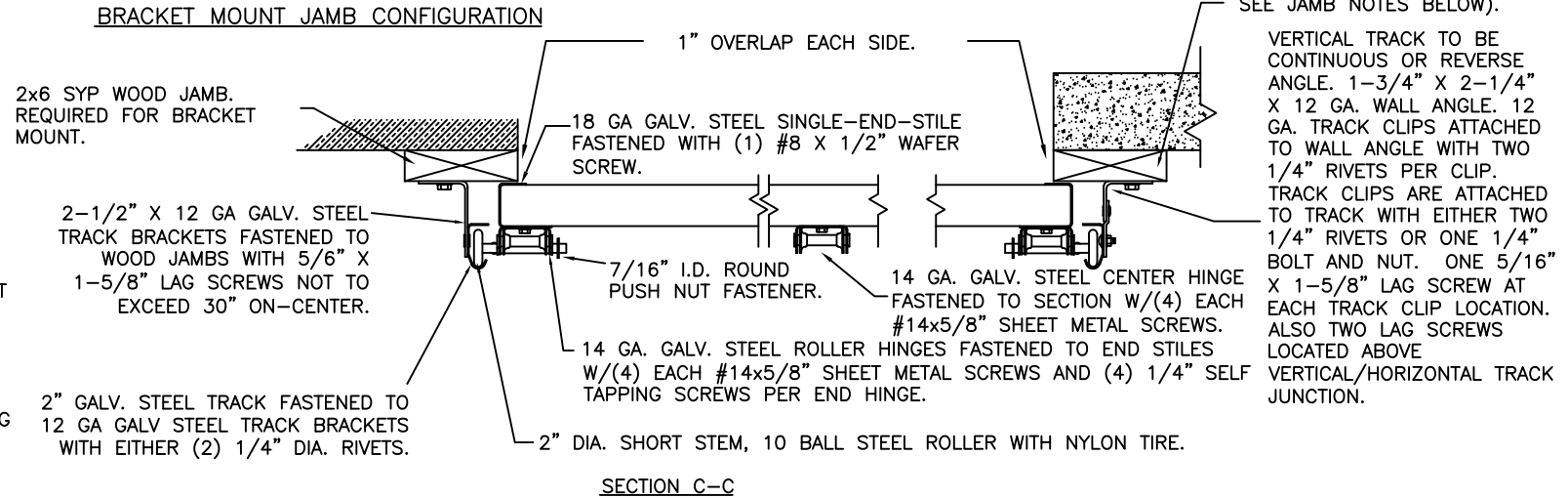

PREPARATION OF JAMBS BY OTHERS.

VERTICAL JAMB ATTACHMENT (WOOD FRAME BUILDINGS):

3/8"x3" LAG SCREWS ON 24" CENTERS. 1-1/8" O.D. WASHER REQUIRED. LAG SCREWS MAY BE COUNTERSUNK (BUT NOT REQUIRED) TO PROVIDE A FLUSH MOUNTING SURFACE. HORIZONTAL JAMBS DO NOT TRANSFER LOAD.

VERTICAL JAMB ATTACHMENT (C-90 BLOCK OR 2,000 PSI MIN. CONCRETE COLUMN):

3/8"x3" SLEEVE ANCHOR BOLTS ON 23" CENTERS (2,000 PSI MIN. CONCRETE). WASHERS INCLUDED WITH SLEEVE ANCHORS.

OR

1/4"x3" TAPCON SCREWS ON 19" CENTERS (2,000 PSI MIN. CONCRETE) OR 11" CENTERS (C-90 BLOCK). 1" O.D. WASHERS REQUIRED WITH TAPCONS.

ANCHORS MAY BE COUNTERSUNK (BUT NOT REQUIRED) TO PROVIDE A FLUSH MOUNTING SURFACE. HORIZONTAL JAMBS DO NOT TRANSFER LOAD.

OTHER JAMB CONFIGURATIONS: REFER TO DASMA TDS-161. A LICENSED DESIGN PROFESSIONAL MAY ALSO BE EMPLOYED TO APPROVE ALTERNATE FASTENERS AND/OR JAMB CONFIGURATIONS.

NOTE: 2x6 WOOD JAMBS ARE NOT REQUIRED WITH CONTINUOUS ANGLE MOUNT TRACK. HOWEVER, IF DESIRED ON STEEL JAMBS OR CONCRETE OR BLOCK WALLS, APPROVED FASTENERS AS DETAILED BELOW SHOULD BE INCREASED IN LENGTH BY 1-1/2" AND INSTALLED DIRECTLY THROUGH THE ANGLE AND 2x6 WOOD JAMBS INTO THE STEEL JAMBS OR CONCRETE OR BLOCK WALLS. ANCHORS CAN BE (BUT ARE NOT REQUIRED TO BE) COUNTERSUNK TO PROVIDE A FLUSH MOUNTING SURFACE. CONTINUOUS ANGLE TRACK CAN BE ANCHORED DIRECTLY TO GROUT REINFORCED BLOCK WALL OR 3,000 PSI MIN. CONCRETE COLUMN OR STEEL JAMBS.

PREPARATION OF JAMBS BY OTHERS

NOTE: THE DESIGN OF THE SUPPORTING STRUCTURAL ELEMENTS SHALL BE THE RESPONSIBILITY OF THE PROFESSIONAL OF RECORD FOR THE BUILDING OR STRUCTURE AND IN ACCORDANCE WITH CURRENT BUILDING CODES FOR THE LOADS LISTED ON THIS DRAWING.



DESIGN ENGINEER:
SCOTT HAMILTON, P.E.
FLORIDA LICENSE No. 63286

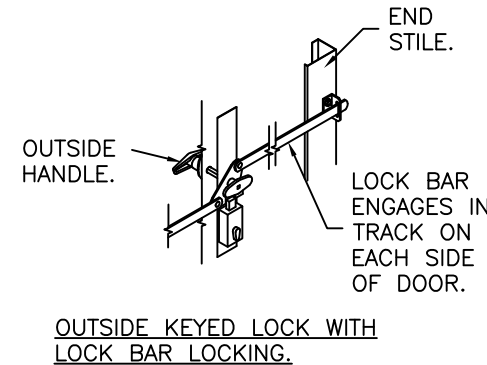
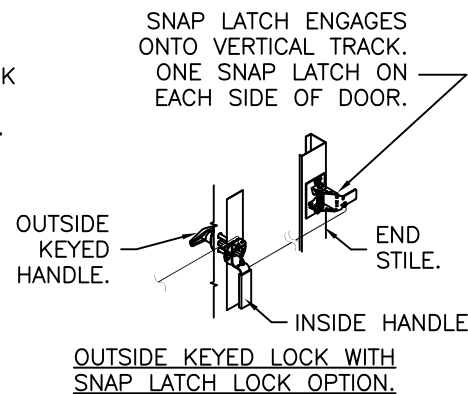
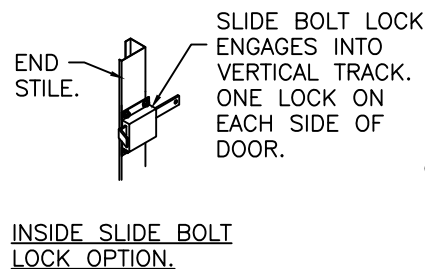

DESIGN LOADS: +25.0 P.S.F. & -25.0 P.S.F.
 TEST LOADS: +37.5 P.S.F. & -37.5 P.S.F.

Unless Stated Otherwise TOLERANCES are
 .0 = ±.031
 .00 = ±.015
 .000 = ±.005
 .0000 = ±.001
 Degrees = ±1/2"
 Unless Stated Otherwise DIMENSIONS ARE IN INCHES.

Glopay
 Building Products Company
 8585 Duke Boulevard
 Mason, OH 45040 USA
 Tel. No. 513-770-4800
 Fax No. 513-770-4853

MANUFACTURING PRODUCT CODE
C-DSIU-1D477

PART NO.: N/A

WINDLOAD RATING
W4 DP25

DESCRIPTION: 1-3/4" INTELLICORE DOORS UP TO 14'2"W (SEE TABLE)

DRAWN BY: S.H. DATE: 8/18/14 SCALE: NTS DWG. B

CHECKED BY: S.H. DATE: 8/18/14 SHEET 2 OF 2 SIZE B

DWG. NO.: 104956 VER: IBC