

INSTALLATION & MAINTENANCE

Steel Residential Garage Door Instructions

Model: _____ Serial No.: _____

(Provided on label on interior door surface)

Size: _____ Register your product online at <http://warranty.clopaydoor.com>

Homeowners Should Retain This Booklet for Future Reference
This Manual Contains Important Safety Information

Installed By: _____

**GALLERY™**
COLLECTION



 **Clopay®** BUILDING PRODUCTS
A Griffon Company

CONSUMER HOTLINE • 1-800-2CLOPAY • 1-800-225-6729

Hours of Operation (ET): Mon. – Fri., 8:30 AM - 7 PM; Sat. 8:30 AM - 5 PM.

Clopay® Pro-Series® Limited Warranty

Steel Door Limited Warranty Information

We will repair or replace (at our option) any garage door section or hardware that is defective in material or workmanship pursuant to the terms of this limited warranty. This warranty extends to and benefits only the original purchaser of the garage door. This warranty does not apply to commercial, industrial or any other non-residential installation.

We will provide, at no cost to you, sections/section components, hardware, springs/spring components or windows to repair or replace defective sections, hardware, springs/spring components or windows. All labor costs associated with the removal and reinstallation of any repaired section/section components, hardware or spring/spring components, and the installation of replacement sections/section components, hardware, spring/spring components, or windows will be your responsibility. We reserve the right to inspect and/or verify any claimed defect.

The applicable limited warranty periods are as follows:

Model #	Paint System	Hardware/ Springs	Sections	Window
GD4L, G4L, GD4LV, G4LV, GD4S, GS, GD4SV, G4SV, GR4L, GR4LV, GR4S, GR4SV	Limited Lifetime	3 yrs.	5 yrs.	10 yrs.
GR5S, GR5SV	10 yrs.	3 yrs.	5 yrs.	10 yrs.
GD5S, G5S, GD5SV, G5SV	15 yrs.	3 yrs.	5 yrs.	10 yrs.

Terms and limitations of the limited warranty are further detailed below:

Paint System Limited Warranty

Clopay warrants the sections of the Models listed above against rust **through** due to the paint finish cracking, checking or peeling (losing adhesion) as follows: (a) in residential single family installations for the years designated above from the date of delivery to the original purchaser; (b) in all other residential installations (including installations on facilities owned in common by condominium associations or similar organizations), for ten (10) years from date of delivery to the original purchaser, pursuant to the terms of this limited warranty.

Hardware/Spring & Spring Component/Sections/Section Components Limited Warranty

We will repair or replace (at our option) any garage door hardware, section/section components, spring and/or spring component that is defective in material or workmanship for the term defined in the chart above, pursuant to the terms of this limited warranty. In addition, we will repair or replace (at our option) any garage door section/section component that is defective in material or workmanship.

Decorative Windows – 10 Year Limited Warranty

Designer windows, snap-in inserts, clear acrylic windows and window frames are warranted for ten (10) years from date of purchase against manufacturing defects and excessive discoloration. This warranty does not cover any damage or loss caused by harmful chemical action, abrasive cleansers, or breakdowns due to climate extremes or environmental conditions. No warranty is available for single pane glass.

WE WILL NOT PAY FOR ANY DAMAGES, INCLUDING INCIDENTAL OR CONSEQUENTIAL DAMAGES, CAUSED BY OR RESULTING FROM DEFECTIVE GARAGE DOOR SECTIONS OR HARDWARE. Some states do not allow the exclusion of incidental or consequential damages, so the above limitation may not apply to you.

Our warranty shall not extend to or cover deterioration due to damage or rust to the garage door caused by fire, an act of God, other accident or casualty, vandalism, radiation, harmful fumes or foreign substances in the atmosphere, or occurring as a result of any physical damage or the failure of paint that is not applied per the manufacturer's specifications after the garage door left our factory, or failure to follow all installation and maintenance instructions. Nor shall our warranty extend to or cover any damages due to normal wear and tear, or claims with respect to any products that in any way or degree have been altered, processed, misused or improperly handled or installed.

If your garage door does not conform to this warranty, notify us in writing at the following address promptly after discovery of the defect. Clopay Building Products, Attn: Consumer Services Dept., 1400 West Market Street, Troy, Ohio 45373. Additional copies of our installation and maintenance instructions may be obtained by calling 1-800-225-6729.

WE MAKE NO OTHER WARRANTIES, REPRESENTATIONS, OR COVENANTS, EXPRESS OR IMPLIED, WITH RESPECT TO THIS PRODUCT, INCLUDING BUT NOT LIMITED TO WARRANTIES, REPRESENTATIONS OR COVENANTS AS TO WORKMANSHIP, DESIGN, CAPACITY, QUALITY, CONDITION, MERCHANTABILITY, OR FITNESS FOR ANY PURPOSE OF THE PRODUCT, EXCEPT FOR ANY "IMPLIED WARRANTY" AS THAT TERM IS DEFINED IN THE MAGNUSON-MOSS WARRANTY-FEDERAL TRADE COMMISSION IMPROVEMENT ACT, SUCH IMPLIED WARRANTIES TO BE LIMITED IN DURATION TO A PERIOD OF ONE YEAR FROM THE DATE OF PURCHASE.

This warranty gives you specific legal rights, and you may also have other rights that vary from state to state.



© Clopay Building Products Company, Inc.
A Griffon Company, Inc. 2008

Table of Contents

Introduction and Opening Preparation

STEP 1 – Things to Know Before You Begin.....	3
STEP 2 – Read Safety Information	4
STEP 3 – Check Headroom, Backroom, Sideroom.....	5
STEP 4 – Removing the Existing Door Springs	6
STEP 5 – Removing Door Sections and Track.....	7
STEP 6 – Preparing the Opening	7

Preparing the New Door

Typical Garage Door Installation Illustration	8
Hardware Components	9

Installing the New Door

STEP 7 – Preparing Bottom Section	10
STEP 8 – Lift Handle Attachment.....	12
STEP 9 – Installing Door Sections.....	13
STEP 10 – Reinforcing the Top Section for Opener Attachment	14
STEP 11 – Assembling and Installing Track	15
STEP 12 – Lock Installation (if included).....	17
STEP 13 – Pull Rope.....	17
STEP 14 – Spring Installation.....	17
STEP 15 – Attaching an Automatic Opener.....	18

Maintenance/Adjustments/Options

Painting and Windows	19
Maintenance	20
Checking and Adjusting the Door	20
Replacement Parts.....	20

STEP 1 – Things to Know Before You Begin

- Read the instructions completely before starting the installation of the door. Becoming familiar with the components before assembling the door will reduce the installation time.
- Be sure all hardware components for your new door are included before removing existing door (see pages 8,9). If your door is missing any parts, call the toll-free Consumer Services number listed on the front of this manual.
- Allow enough time to do the work; removing an existing door will take approximately 1-3 hours.
- An assistant may be required for lifting the unsprung door. It can weigh from 100 to 500 pounds.
- A typical installation takes between 9 and 12 hours to complete.
- Keep in mind when planning the installation that the garage will be open and unsecured when disassembling the old and assembling the new door.
- If the garage door is the only opening in the structure make sure everything you need is inside. You will have no way of leaving the garage until the track is assembled and installed. This will take approximately 5 hours.
- To avoid damage to the door, you must reinforce the top section of the door in order to provide a strengthened mounting point for attachment of an automatic opener (see page 14).
- Low Headroom doors require special instructions. Options for doors with low headroom can be found on page 5. Purchase of additional hardware may be required. Check headroom requirements in the chart on page 5 before beginning.
- To avoid installation problems which could result in personal injury or property damage, never reuse old track or hardware.
- Doors installed in high windload regions (Florida and other high wind prone areas) may require additional reinforcement beyond what is detailed in these instructions. Please refer to supplemental instructions for these areas.
- Express warranties apply only to doors installed using original, factory-supplied sections, parts, and hardware installed in strict accordance with these instructions.

Tools Needed

- “C” Clamps or Locking Pliers
- Hammer
- Screwdriver
- Tape Measure
- Level
- Socket wrench kit
- Pliers
- Drill, 1/4", 3/16", & 3/8" drill bits, and 7/16" socket bit
- Step ladder
- Saw horses (with carpet or other soft material on top surface; 2 needed for doors up to and including 9'0" wide, 3 needed for doors over 9'0" wide) or other supports for placing section on while assembling
- Hacksaw
- Wood Saw
- T-Square
- Additional tools may be required; see the Spring Supplement for more information.

Additional Material Required

- Light household oil
- 1-1/4" x 1-1/4" Minimum punched angle
 - 13 ga. (3/32") minimum thickness for Operator Reinforcement (see page 14)
 - 16 ga. (1/16") minimum thickness for rear track hangers on doors weighing up to 300 lbs. that use torsion springs, or doors weighing up to 150 lbs. that use extension springs. If your door exceeds these weight limitations, or if you do not know the weight of your door, 13 ga. angle should be used. (See page 16)
- Eight 3/8" x 1" bolts and nuts for rear track hangers
- Six 5/16" x 11/2" lag screws for rear track hangers
- Ten 10d 3" nails
- Stop Molding
- Wood Block
- Rope

STEP 2 – READ THIS SAFETY INFORMATION IMPORTANT!

To Protect Yourself From Injury You Must Carefully Read The Following Safety Information and Warnings Before You Install Or Use Your New Garage Door

- You can install your new garage door yourself IF...
 - a) you have help (it may weigh up to 500 lbs.);
 - b) you have the right tools and reasonable mechanical aptitude or experience; and
 - c) you follow these instructions very carefully.
- Garage doors use springs to balance them. There are two types of springs installed — extension or torsion. Each of these is available in either a standard or EZ-Set™ assembly option. Please look at the drawings on page 8 to see which springs your old door has.
- **If your old door uses torsion springs, do not attempt to remove the door or the springs yourself.** Have a qualified door repair service remove them. Attempting to remove a torsion spring assembly without proper training or tools may result in an uncontrolled release of spring forces which can cause serious or fatal injury.
- **Only the track specified and supplied with the door should be used.**
- The brackets at the bottom corners of your garage door are under great tension. **Do not attempt to loosen any bracket fasteners except when and as directed in detail in the following instructions.** Otherwise, the bracket could spring out with dangerous force.
- **Do not permit children to play beneath or with any garage door or electric operating controls.**
- In removing a garage door that has extension springs, follow the instructions carefully, including the use of “C” clamps or locking pliers on both sides of the door in order to keep the door from moving once the springs are removed.
- Keep hands and fingers clear of section joints, track, and other door parts when the door is opening and closing to avoid injury. The lift handles are located for safe operation as well as easy use.
- Bolts must be installed at the rear end of horizontal tracks. These act to stop the rollers and keep the door from rolling off the back of the track.
- Track installations must use sway braces on the rear track hangers to prevent sideways movement. If the tracks are not firmly stabilized they might spread, allowing the door to fall and cause severe injury and damage.
- Springs, cables, and bottom fixtures are under strong spring tension. **Do not attempt to loosen any fasteners on these components.** You could suddenly release spring forces and risk severe injury.
- If the garage door and/or any of the supporting track are damaged, operating the door could be hazardous. Call an authorized representative of the manufacturer or professional door repair service promptly.
- If repairs are ever required to your door, safety and trouble-free operation can be best assured by using original replacement parts.
- Once you have completed the installation of your new garage door, please be sure that your garage complies with all applicable ventilation requirements before you enclose any vehicles in the garage. Good ventilation avoids fire and health hazards caused by fumes accumulating within a well-sealed garage.
- Clopay Building Products Company disclaims all liability for any installation that is not in compliance with applicable state or county building codes.
- Doors equipped with automatic door operators can cause serious injury or death if not properly adjusted and operated. To ensure safety of these doors:
 - a) test the sensitivity of the operator's safety reverse mechanism monthly;
 - b) if your door has a pull down rope, you must remove the pull down rope;
 - c) make sure the door remains unlocked;
 - d) do not allow children to play with the controls.



WARNING

In the interest of safety this symbol means **WARNING** or **CAUTION**. Personal injury and/or property damage may occur unless instructions are followed carefully.

STEP 3 – Check Headroom/ Backroom/ Sideroom

Headroom is the space needed above the top of the door for the door, the overhead tracks, and the springs. Measure to check that there are no obstructions in your garage within that space. The normal headroom space requirement is shown in Table 3-A. The backroom distance is measured from the back of the door into the garage, and should be at least 18" more than the height of the garage door. A minimum sideroom of 3-3/4" (5-1/2" for EZ-Set™ Extension Spring) should be available on each side of the door on the interior wall surface to allow for attachment of the vertical track assembly. The rough opening should be the same size as the door. (FIG. 3-A)

Track Radius: The radius of your track can be determined by measuring the dimension "R" in FIG. 3-B. If dimension "R" measures 11" to 12", then you have a 12" radius track. If "R" equals 14" to 15", then you have a 15" radius track. (FIG. 3-B)

Headroom requirements

The standard headroom space requirement is shown in Table 3-A at right. (See page 8 if you have a question on which type of spring you have.)

Low Headroom? If you have restricted headroom, several remedies are available. See Table 3-B for various options.

NOTE: Installation of the various Low Headroom Options differs from the installation of a standard headroom door. Supplemental instructions are included with the hardware of each Low Headroom Option.

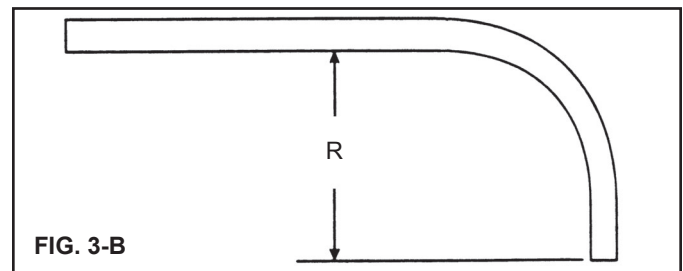
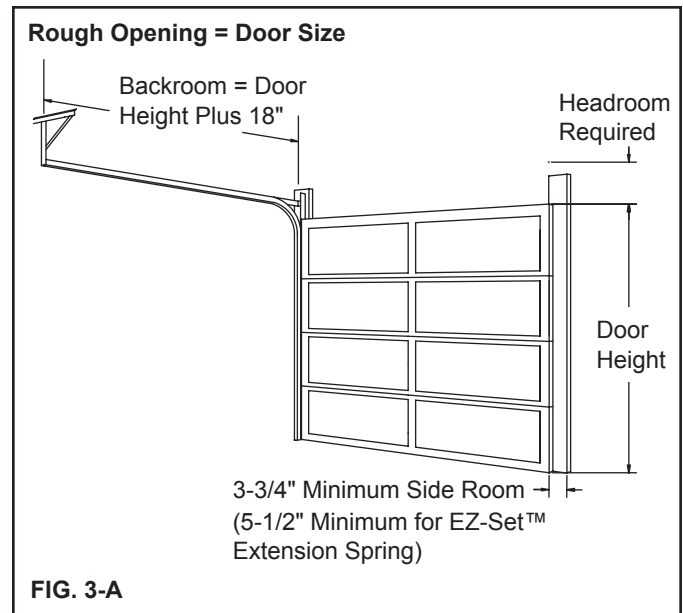

Table 3-A: Standard Headroom Requirement Chart

Spring Type	Track Radius	Headroom Required
EZ-Set™ Extension Spring or Extension Spring	12"	10"
EZ-Set™ Extension Spring or Extension Spring	15"	12"
EZ-Set™ Torsion Spring or Torsion Spring	12"	12"
EZ-Set™ Torsion Spring or Torsion Spring	15"	14"

Table 3-B: Low Headroom Options*

Spring Type	Low Headroom Option	Reduces Required Headroom to:	How can I get this option?
Extension and EZ-Set™ Extension	Low Headroom Track	4-1/2"	Order Low Headroom Track.
Extension and EZ-Set™ Extension	Low Headroom Conversion Kit (Modifies Standard Track)	4-1/2"	Available at most retail stores.
Extension and EZ-Set™ Extension	Quick Turn Bracket	8" on 12" Radius Track	Order Quick Turn Bracket Set.
EZ-Set™ Torsion	Low Headroom Track (Front Mount Spring)	9-1/2"	Order Low Headroom Track.
EZ-Set™ Torsion	Low Headroom Conversion Kit (Modifies Standard Track)	9-1/2"	Available at most retail stores.
Torsion	Low Headroom Track (Front Mount Spring)	9-1/2"	Available from and should be installed by professional installer only.
Torsion	Low Headroom Track (Rear Mount Spring)	4-1/2"	Available from and should be installed by professional installer only.

*About 3" of additional headroom height at the center plus additional backroom is needed to install an automatic garage door opener. Check door opener instructions.

STEP 4 – Removing the Existing Door Springs



WARNING

Garage doors use springs to balance the door weight. There are two types of springs used — extension and torsion. Each of these is available in either a standard or EZ-Set™ assembly option. Please look at the drawings on page 8 to see which springs your old door has installed. **If your present door uses standard torsion springs, do not attempt to remove the door or the springs yourself.** They should be removed by a qualified door service professional. Attempting to remove a torsion spring assembly without proper training and tools may result in an uncontrolled release of spring forces which can cause serious or fatal injury.

Extension springs and EZ-Set™ Springs are shown on a sectional garage door in the illustration on page 8 to see which springs your door has. The following instructions detail how to remove these springs.



WARNING

Serious injury could result if spring tension has not been released before other work begins.

Removing Extension Springs



WARNING

Use two or more helpers to assist you in lowering the door.

Step 4-1a: Raise the door to the full open position. Place “C” clamps or locking pliers tightly on both sides of the track under the door so the door is held securely in place. With the door fully open, most spring tension has been removed. (FIG. 4-A) Do not attempt to remove or adjust extension springs with door in the down position. Use “C” clamps to keep the door from moving or falling once the springs are removed.

Step 4-2: Detach the cable at both ends. Disassemble and remove the springs and cable completely from the door.

NOTE: Wood blocks should be placed underneath the door when closing to prevent fingers from being trapped.

Step 4-3: Remove the “C” clamps from the track and carefully close the door.

Some large doors might weigh as much as 500 pounds when the spring tension is removed. The weight of the door will not be apparent when you first begin to close the door. The door will feel progressively heavier as it is lowered until its full weight (as much as 500 pounds) is realized about one foot from the floor. A single car door may weigh as much as 200 pounds. (FIG. 4-B)



WARNING

To avoid injury, keep hands and fingers clear of section joints, track, and other door parts while the door is opening and closing.

Removing EZ-Set™ Extension or Torsion Springs

Step 4-1b: With the door in the DOWN position, position a drill with a 7/16” socket bit over the worm drive. Using the reverse (counter-clockwise) direction on the drill, remove all the tension from the spring (repeat for each side). After spring tension has been removed, detach the lift cables at both ends. Disassemble and remove the springs and cable completely from the door. (FIG. 4-C)

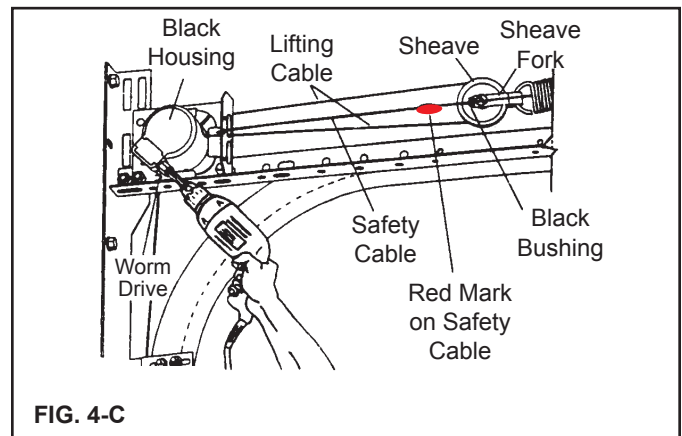
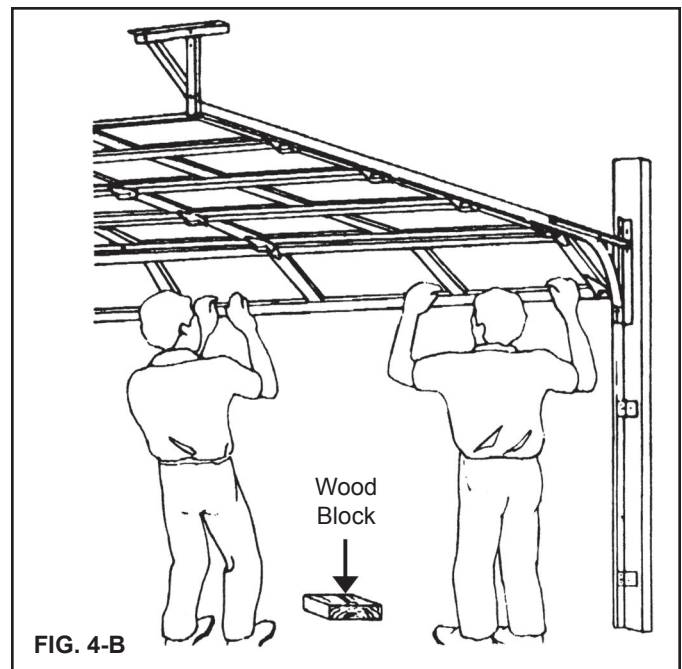
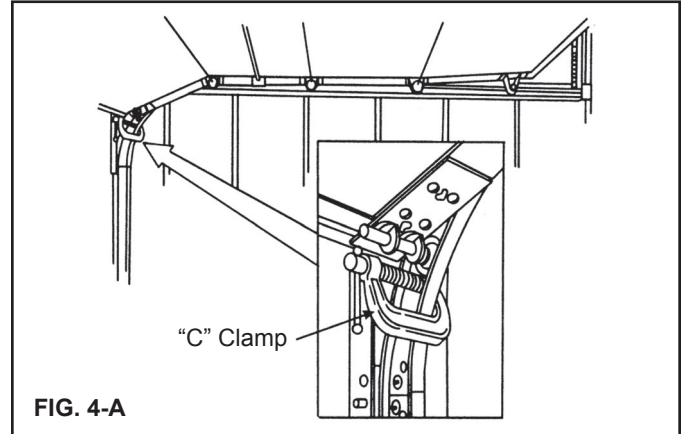

STEP 5 - Removing Door Sections & Track

Step 5-1: The door can now be disassembled. Starting with the top section, remove the hardware and unstack the sections one at a time. (FIG. 5-A)

Step 5-2: After all sections have been removed from the opening, detach all remaining track and hardware from the jambs. The hangers that attach the rear ends of the overhead track to the ceiling (called rear track hangers) in many cases can be reused on the new door if made of 13 gauge (3/32") or heavier steel and is not loose or unstable. (FIG. 5-B)



WARNING

To avoid installation problems which could result in personal injury or property damage, use only the track specified and supplied with the door. Do not attempt to reuse old track.

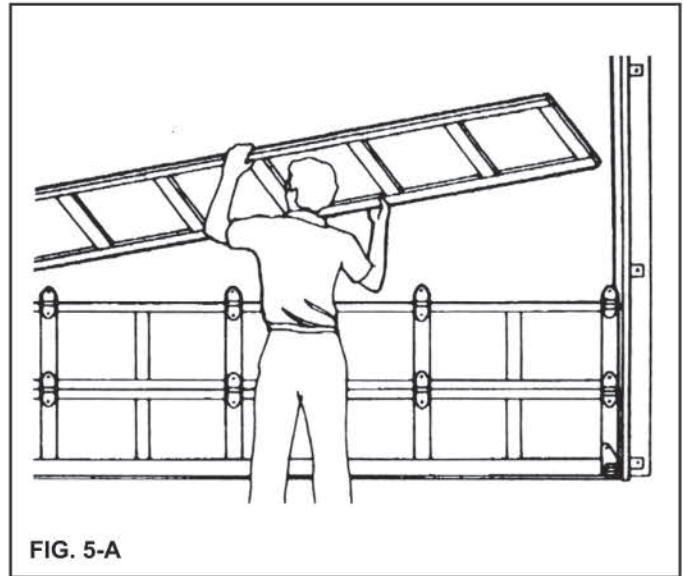

FIG. 5-A

STEP 6 - Preparing the Opening

Step 6-1: On the inside of the garage your opening should be framed with wood jambs, 2" x 6" if possible. The side jambs should extend to approximately the same height as the headroom required. If you have just removed an old door, the jambs should be inspected for the condition of the wood. If the wood is rotten, it should be replaced now. The jambs should be plumb and the header should be level. If there are any bolts fastening the jambs to the wall, the heads should be flush so they don't interfere with the installation of your new door. (FIG. 6-A)

NOTE: Rough opening (without stop molding) = Door size

Step 6-2: Door stop molding should be temporarily nailed to the edges of the jambs flush with the inside. (FIG. 6-B)

Stop molding featuring a built-in weather seal is offered as an option.

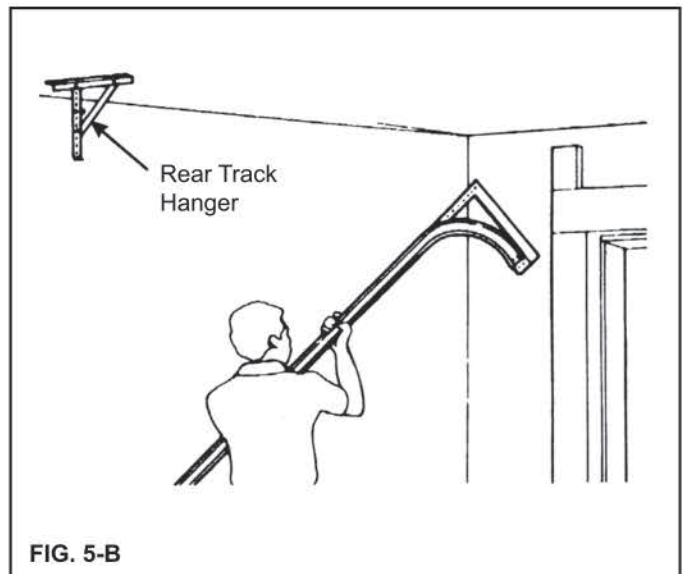

FIG. 5-B

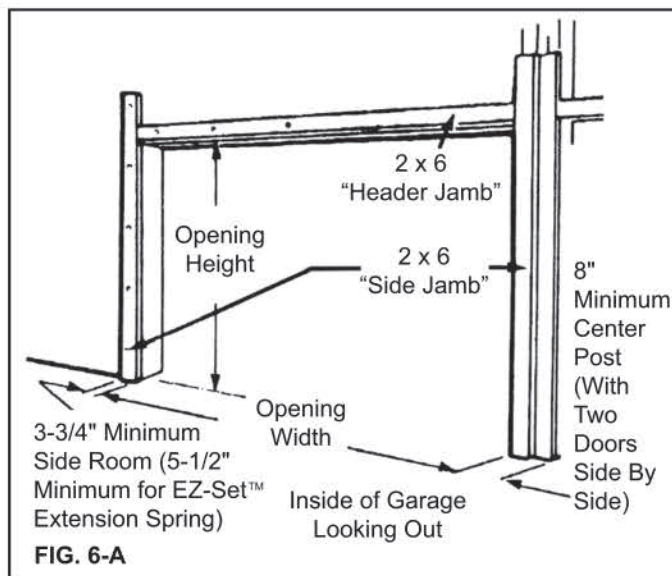

FIG. 6-A

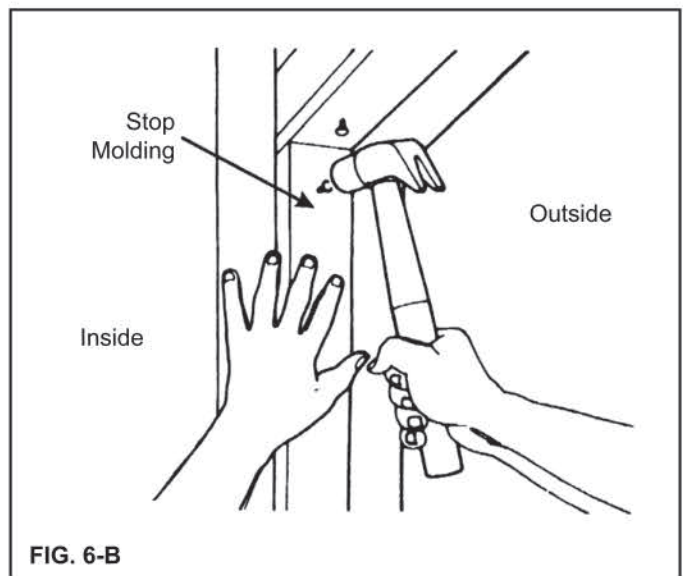
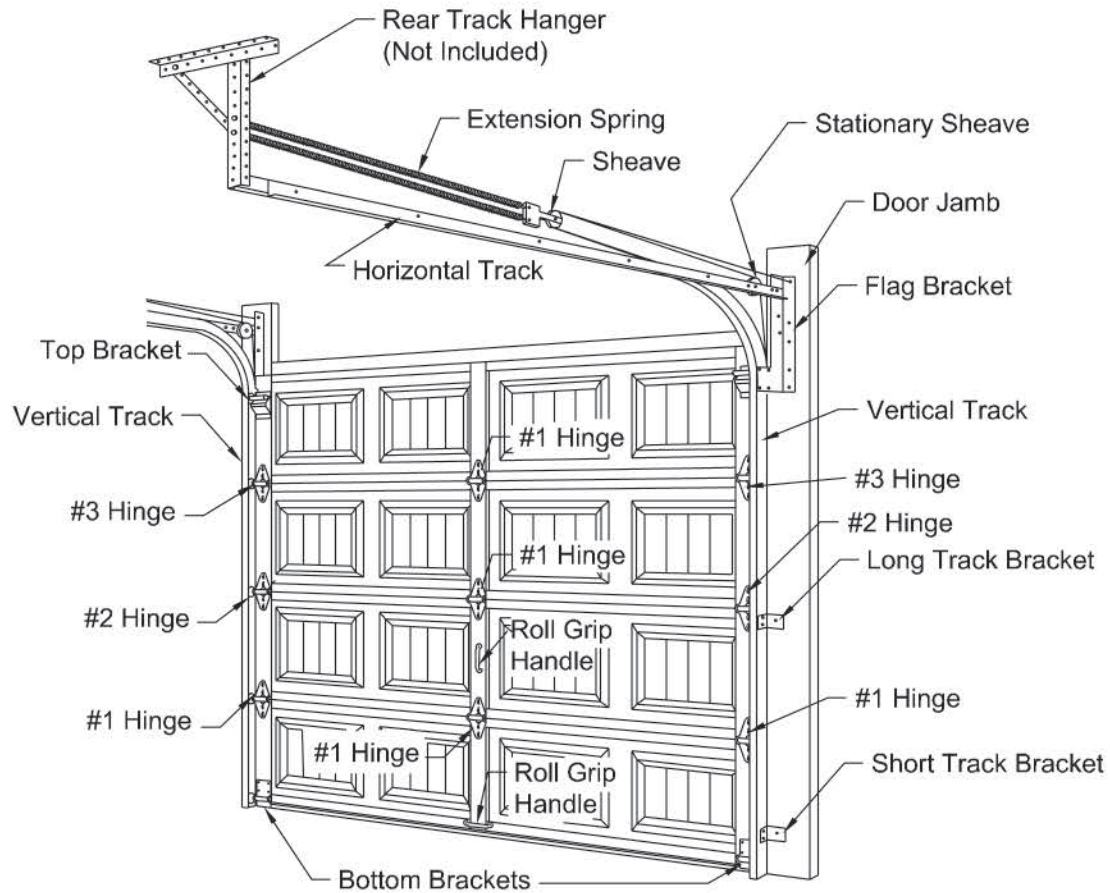
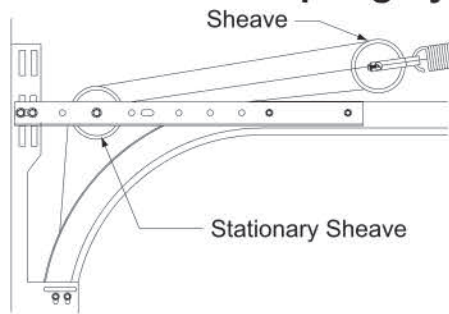

FIG. 6-B

Extension Spring System Shown on Complete Door



Standard Extension Spring System



Standard Torsion Spring System

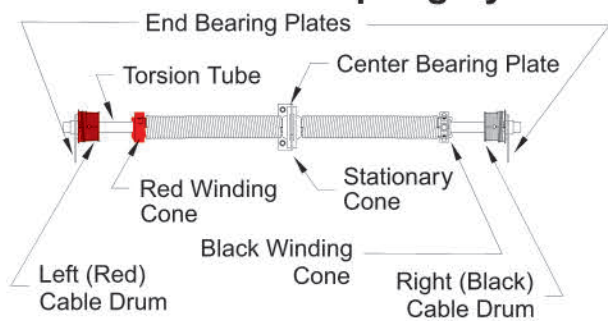

EZ-Set™ Extension Spring System

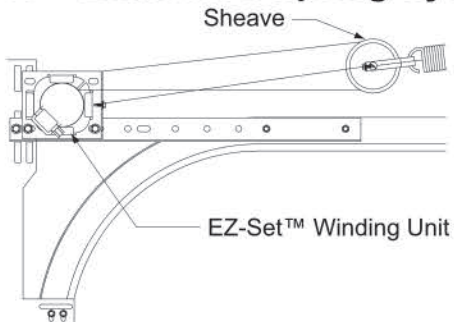

EZ-Set™ Torsion Spring System

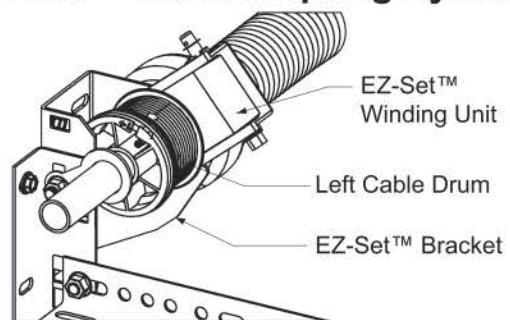









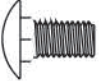



NOTE: The above illustration represents a composite of many of the features found on a variety of garage doors. While not representative of any one door, it provides a handy reference for the location of specific components

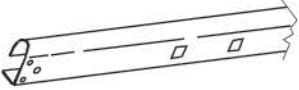



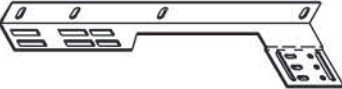



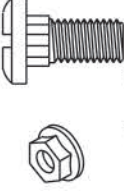
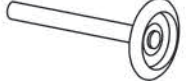

Hardware Components

NOTE: All doors will receive (1) spring kit and (1) or more springs. Separate spring installation supplemental instructions should be included with door hardware. This supplement contains a list of all spring related hardware along with instructions on proper spring installation.

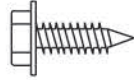
All doors will receive (2) of these items:

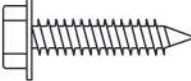
	Track Bracket (Longer)		3/8"-18 x 3/4" Lg. Carriage Bolt		3/8" Washer
	Track Bracket (Shorter)		Top Bracket		Curved Horizontal Track
	#2 Hinge		Bottom Bracket (1) Pair		Vertical Track
	#3 Hinge		Horizontal Angle		Cable Assembly
	Track Bracket (Longest, 8'0" Doors Only)		Flag Bracket (1) Pair		3/8" Hex Nut

(While not representative of any one model, the quantities below can be used as a guide. In some instances, extra screws/bolts are provided in the event of strip out or loss of parts. Other door sizes not shown below may have different hardware amounts.)

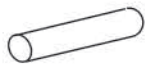
Description:	Qty.	Description:	Door Size:	Qty.	
	Single Car Doors 8' - 9'W x 7'0"H		Rollers	4 Section Doors	16
	Double Car Doors 16'W x 7'0"H				22
	Single Car Doors 8' - 9'W x 8'0"H		#1 Hinge	Single Car Doors 8' - 9'W x 7'0" - 8'0"H Double Car Doors 16'W x 7'0" - 8'0"H	20
	Double Car Doors 16'W x 8'0"H				26
	Single Car Doors 8' - 9'W		Roll Grip Handle	Single Car Doors 8' - 9'W Double Car Doors 16'W	1
	Double Car Doors 16'W				11
	Single Car Doors 8' - 9'W		Horizontal Spade Handle	Single Car Doors 8' - 9'W Double Car Doors 16'W	56
	Double Car Doors 16'W				90
	Single Car Doors 8' - 9'W		5/16" x 1-5/8" Lag Bolt	6'0" - 7'0" Doors Over 7'0" Doors	0
	Double Car Doors 16'W				1
	All Doors		Black Head Carriage Bolt	Single Car Doors 8' - 9'W Double Car Doors 16'W	1
					6
	Single Car Doors 8' - 9'W		Backup Plate	Single Car Doors 8' - 9'W Double Car Doors 16'W	2
	Double Car Doors 16'W				4
	Single Car Doors 8' - 9'W	Keyed Lock Kit (Parts are detailed in Lock instructions)	All Doors	0 or 1	6
	Double Car Doors 16'W				10

*More struts may be required in high windload areas.

STEP 7 - Preparing Bottom Door Section

Step 7-1: Spread the hardware on the garage floor in groups so that you can easily find the parts.

Step 7-2: Find the section with the aluminum weatherstrip retainer fastened to one edge. The aluminum weatherstrip retainer is on the bottom edge of the bottom section. Place the section on saw horses face down. (FIG. 7-A) Be sure to cover saw horses with carpet or cloth so as not to scratch section.

Step 7-3: Bend and break apart bottom brackets by hand along end tabs as shown. (FIG. 7-B) **Be sure to remove connecting tab.**

Step 7-4: Insert safety tabs on bottom bracket into slots on end stile of door. Slide bottom bracket up to fully engage tabs. (FIG. 7-C) Attach all hardware with #14 x 5/8" sheet metal screws. Attach the bottom brackets with two screws to the bottom corners of the section. Screws go into the end stiles. Hook the looped ends of the steel lift cable over the buttons on the bottom brackets. (If your door came with standard extension springs, the lift cables are the longer and smaller diameter of the two sets of cable. If your door came with EZ-Set™ Extension Springs, do NOT attach lift cables at this time! Do NOT use the shorter safety containment cables as lift cables, as this can cause improper door function). (FIG. 7-D)



WARNING

Failure to properly engage safety tabs on bottom bracket into slots on edge of door can result in severe injury when spring tension is applied.

Step 7-5: Hinges are identified by number 1, 2, 3 (and sometimes 4, on 5 section doors only). This number is stamped on the hinge. Attach a number 1 hinge at each center stile location along the top edge of the section using #14 x 5/8" sheet metal screws. The number is stamped on the side of the hinge that is to be attached to the section. (FIG. 7-E)

NOTE: If Table 7-A below shows a need for a reinforcing strut on the bottom section, it should be attached just above bottom brackets. Use 1/4" x 3/4" self tapping screws to attach strut as shown in the illustration. When pre-drilled holes in strut do not line up vertically with stiles, you will be required to drill (2) 3/16" pilot holes through the strut and the stile at each end stile and each center stile, or use a drill or impact wrench with a 7/16" socket to drive self-tapping screws through strut and stile. (FIG. 7-E)

Table 7-A - Sections Requiring Struts

Door Width	Bottom Section	3rd Section	Top Section
15 & 16 ft.	-	-	✓
17 & 18 ft.	✓	✓	✓
Over 18 ft. 2 in. – One strut per section			

NOTE: Doors installed in high windload regions (Florida and other high wind prone areas) may require additional reinforcement beyond what is detailed in these instructions. Please refer to supplemental windload instructions for these areas.

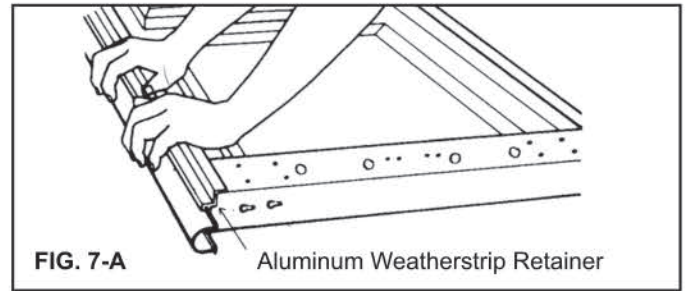

FIG. 7-A Aluminum Weatherstrip Retainer

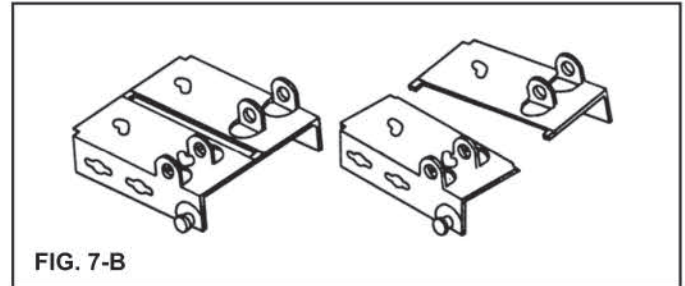

FIG. 7-B

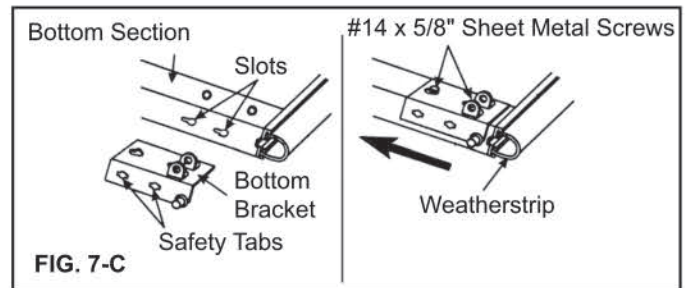

FIG. 7-C

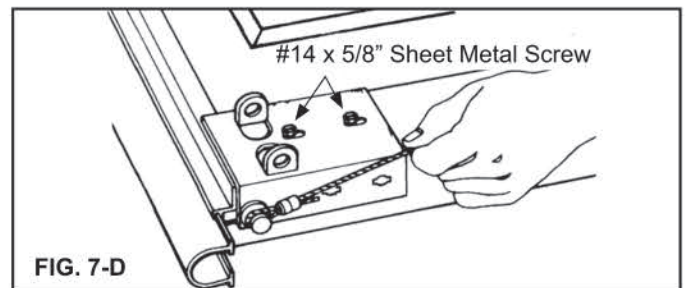

FIG. 7-D

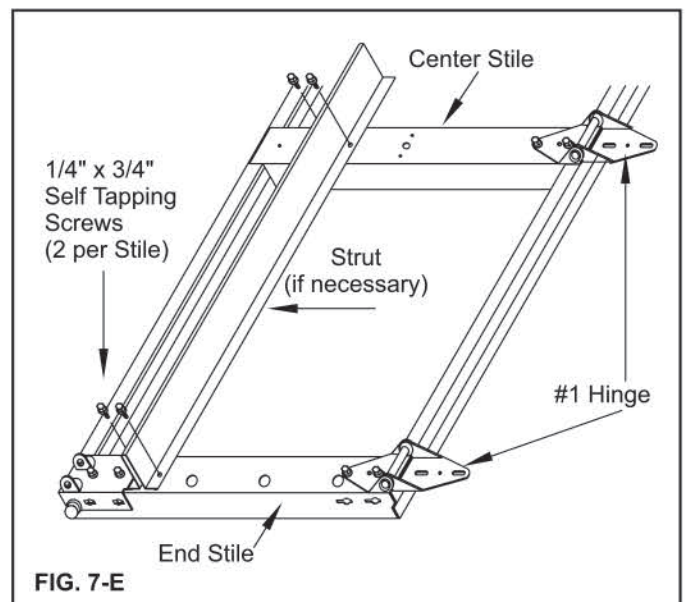

FIG. 7-E

Step 8 – Lift Handle Attachment

Bottom Section

Step 8-1: Using the supplemental templates provided in the handle bag, determine the handle configuration for your door size.

Step 8-2: From the front of the door section, find the center of the distance between embosses. According to the template provided in the bottom handle packaging (FIG T1) line up the center lines and the bottom of section. Drill two 1/2" holes where indicated through the front skin of the section and insulation (if applicable), but STOP BEFORE drilling through the back skin.

Step 8-3: Flip over the section. From the back of the door drill two 5/16" holes, through the aluminum astragal retainer, using the template provided. (FIG T2)

Step 8-4: Slide the black headed 1/4" carriage bolt (1) through the horizontal spade handle (9), the handle spacer (3), the front of the section, the back of the section, the roll grip handle (8), and finally secure with 1/4" flange nut (5). (FIG. 8-A)

Step 8-5: Repeat Step 8-2 through 8-4 for second bottom handle (if applicable.)

Second Section (to be installed at the completion of Step 9-4. Not Required on Doors with Outside Keyed Lock)

Step 8-6: On the back of the provided template find your door handle configuration. Use the template that is on the other side to drill the holes in your second section, it will be either FIG T3 or FIG T4.

Step 8-7: From the front of the door section, find the center of the distance between embosses and the middle of the section height. According to the template found in Step 8-6 line up the vertical and horizontal center lines. Drill the indicated 1/2" holes through the section and insulation (if applicable.)

Step 8-8: If you have a single handle as shown in FIG 8-B, skip to Step 8-7. Attach the handle backer plate (4) to the stile with two 3/4" hex head sheet metal screws (7) going into the center stile. The top sheet metal screw will also pass through the top hole of the roll bar handle (8). (FIG 8-A)

Step 8-9: Slide the black headed 1/4" carriage bolt (1) through the vertical spade handle (2), the handle spacer (3), the front of the section, the back of the stile or the handle backer plate (7), roll bar handle (8 if applicable) and finally secure with 1/4" flange nut (5). (FIG. 8-A or FIG. 8-B)

Step 8-10: Take a 3/4" hex head self-tapping screw (6) and drill it through the open hole of the roll bar handle (8) into the stile by passing through the hole in the handle backer plate (4 if applicable.) (FIG. 8-A or FIG. 8-B)

Step 8-11: Repeat Step 8-7 through 8-10 for second handle set (if applicable.)

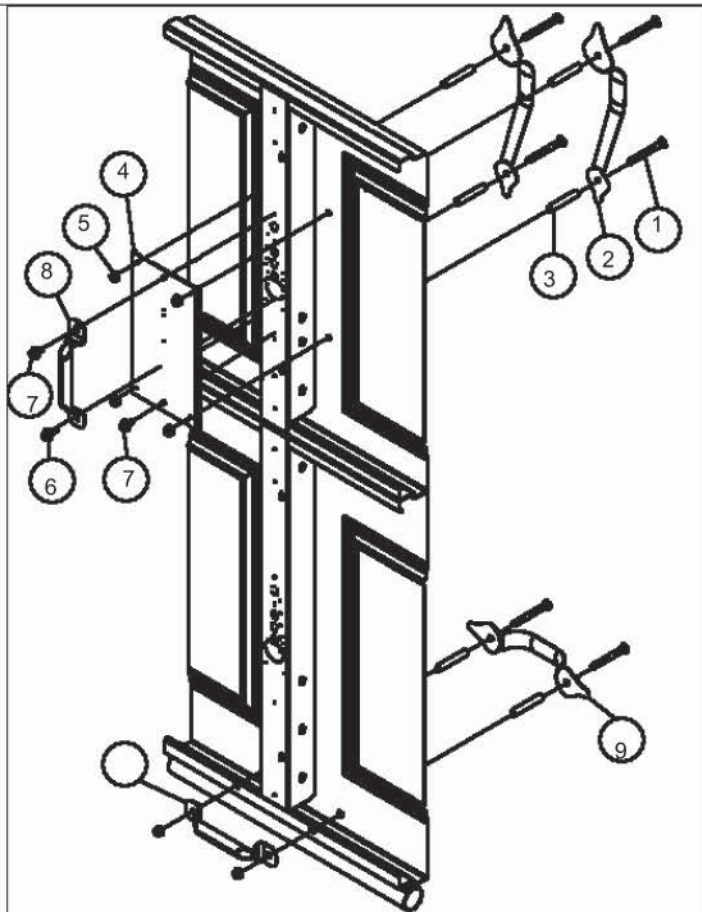

FIG. 8-A

Item No.	Description
1	1/4" x2-1/2" Black Head Carriage Bolt
2	Black Vertical Spade Handle
3	1/2" OD x 2" Long Handle Spacer
4	Handle Backer Plate
5	1/4-20 Serrated Flange Nut
6	#14 x 3/4" Hex Head Self Tapping Screw
7	#14 x 3/4" Hex Head Sheet Metal Screw
8	Roll Grip Handle
9	Black Horizontal Spade Handle

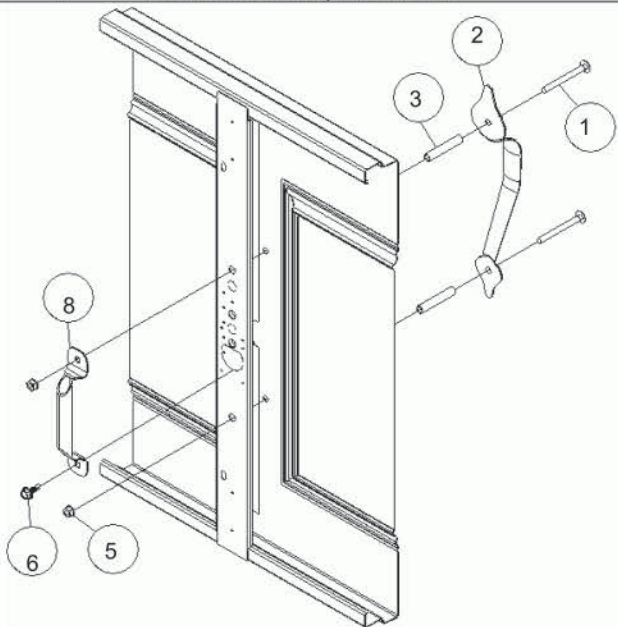

FIG. 8-B

STEP 9 - Installing Door Sections

Step 9-1: Place the section in the opening so that it is against the stop molding and centered from side to side. Place a level on the section and use a piece of wood under one end or the other (if necessary) to make the section level. (FIG. 9-A)

Step 9-2: Remove the level and drive a 3" nail in the jambs at each end and bend it over the edge of the section to hold the section in place. (FIG. 9-B)

NOTE: These nails are all that will hold the stacked door section in place until the tracks are secured to the back jambs. Be sure the nails hold the sections firmly in position.

Step 9-3: With the Table 9-A below, determine the order in which you will attach the remaining sections.

NOTE: If a lock assembly was ordered with the door, the holes for the lock may be predrilled. (Lock templates are included in the lock instructions for doors without predrilled holes.)

Table 9-A - Section Order for Various Door Heights

Door Height	1st (Bottom) Section	2nd (Lock) Section	3rd Section*	4th Section
6'0"	24"	24"	24"	-
6'3"	18"	18"	18"	21"
6'6"	21"	18"	18"	21"
6'9"	21"	21"	18"	21"
7'0"	21"	21"	21"	21"
7'3"	21"	21"	21"	24"
7'6"	24"	21"	21"	24"
7'9"	24"	24"	21"	24"
8'0"	24"	24"	24"	24"

* Section with general safety label.

Step 9-4: Place the next section face down on the saw horses. If your door is predrilled for a lock, this section will be the one with holes in the center of the panel face. Identify the bottom edge as shown in the illustration. (FIG. 9-C)

Attach a number 2 hinge to each end at the top edge using #14 x 5/8" sheet metal screws. Remember that the number is stamped on the side of the hinge that is to be attached to the section. Attach a number 1 hinge to at each center stile location along the top edge of the section.

Step 9-5: Keyed Lock Installation. If you wish to install a keyed lock, begin the lock installation now according to the supplemental instructions included with the lock hardware. If your door did not come with a keyed lock, install lift handle as shown on previous page.

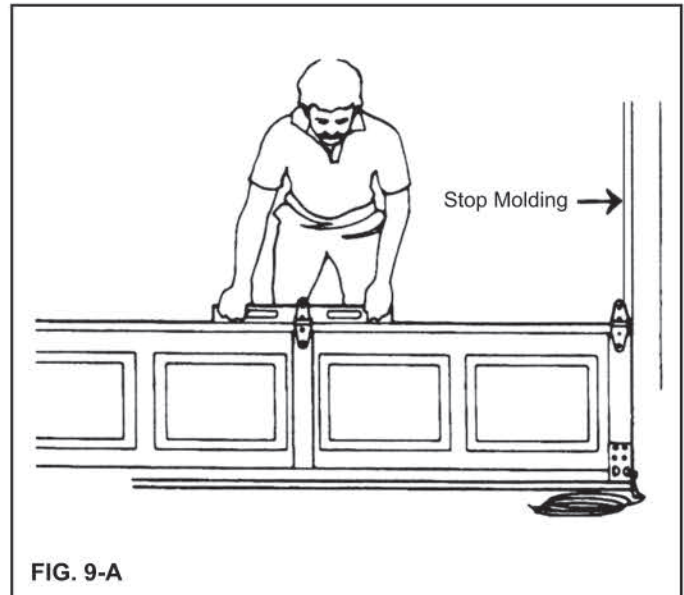

FIG. 9-A

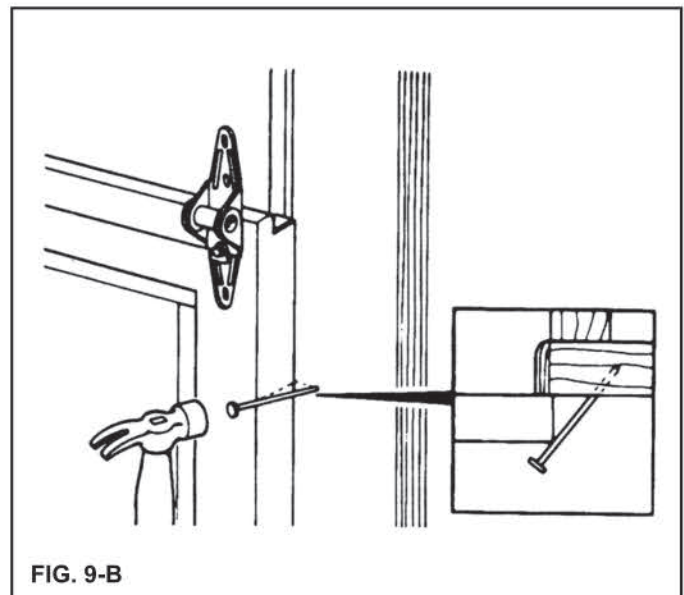

FIG. 9-B

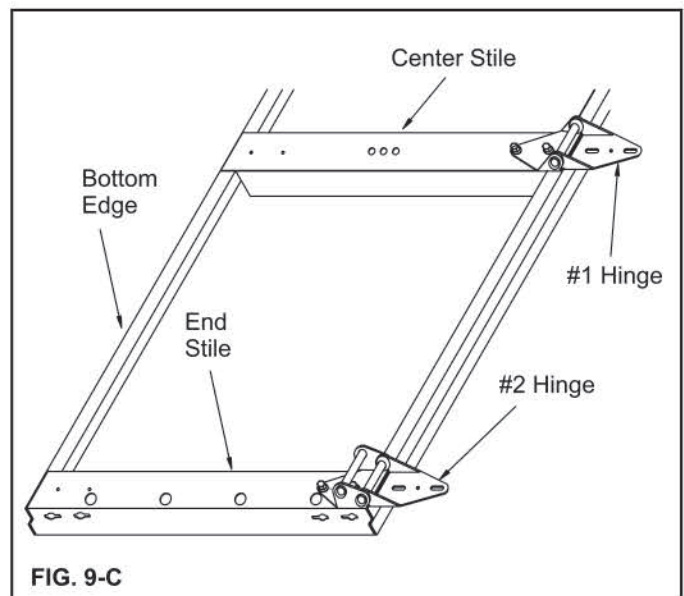

FIG. 9-C

STEP 9 - Installing Door Sections (Continued)

Step 9-6: Place the second section on top of the first section. Drive a 3" nail in the jambs at each end and bend it over the edges of the section to hold the section in place. Attach the hinges from the top of the first section to the bottom of the second. (FIG. 9-D)

Step 9-7: Place the third section on saw horses. Attach #3 hinges to the ends at the top edge and #1 hinges to all other stiles along the top edge using #14 x 5/8" sheet metal screws. (FIG. 9-E)

NOTE: If your door was supplied with more than 1 strut (consult Table 7-A on bottom of page 10), use 1/4" x 3/4" self tapping screws to attach strut as shown in the illustration. When pre-drilled holes in strut do not line up vertically with stiles, you will be required to drill (2) 3/16" pilot holes through the strut and the stile at each end stile and each center stile, or use a drill or impact wrench with a 7/16" socket to drive self-tapping screws through strut and stile. (FIG. 9-E)

Step 9-8: Place the third section on top of the other sections and nail in place as before. Attach the hinges from the top of the previous section to the bottom of this section. (FIG. 9-D)

Step 9-9: Place the last section on the saw horses. Attach the top roller brackets as shown. The top roller brackets are to be attached with three (insulated doors) or four (non-insulated doors) #14 x 5/8" sheet metal screws. The top of the bracket should be located 3-1/4" down from the top of the door. The bottom of the bracket goes in smaller holes 6-1/4" from top of section. (FIG. 9-F)

If your door was supplied with any struts (consult Table 7-A on bottom of page 10), use 1/4" x 3/4" self tapping screws to attach strut as shown in the illustration. When pre-drilled holes in strut do not line up vertically with stiles, you will be required to drill (2) 3/16" pilot holes through the strut and the stile at each end stile and each center stile, or use a drill or impact wrench with a 7/16" socket to drive self-tapping screws through strut and stile. (FIG. 9-F)

Step 9-10: Place a roller in the top and bottom brackets and in the tubes in each of the hinges at the ends of each section. Some hinges have two tubes. Place the roller in the tube that is farthest from the face of the door. (FIG 9-G)

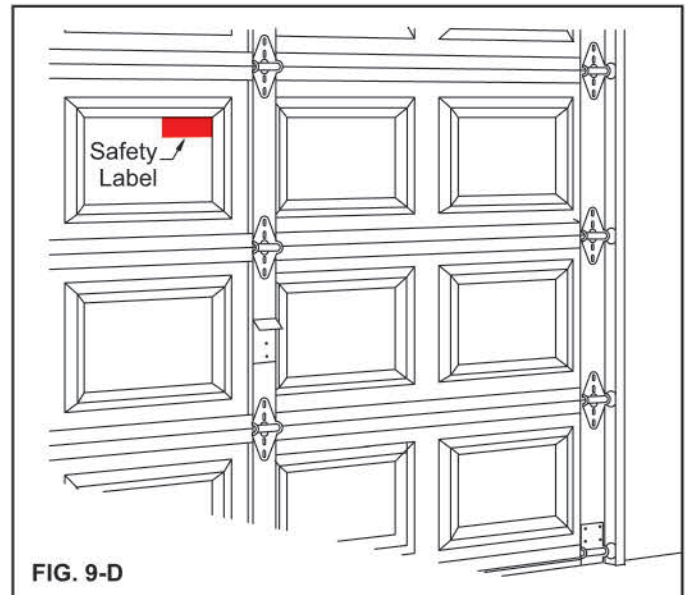

FIG. 9-D

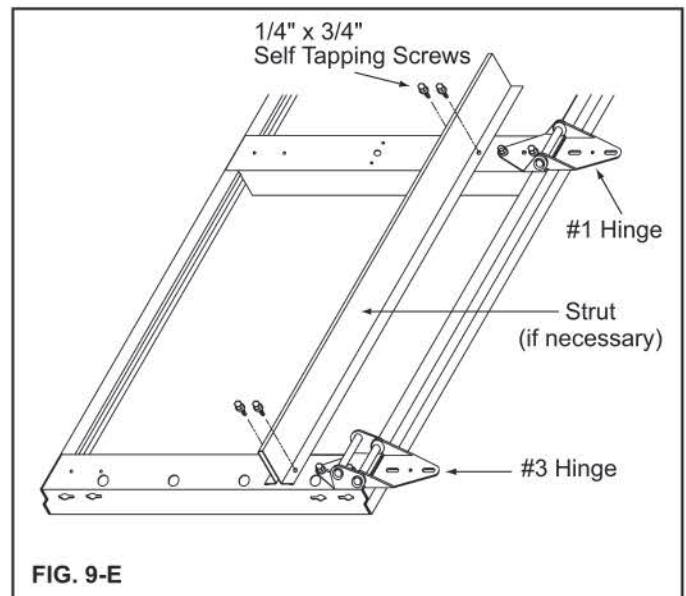

FIG. 9-E

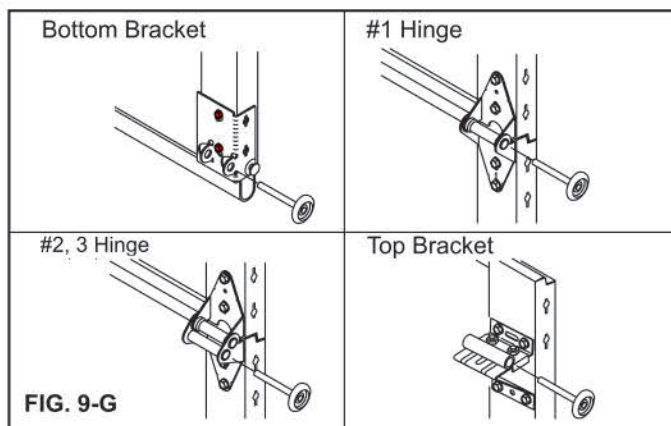

FIG. 9-G

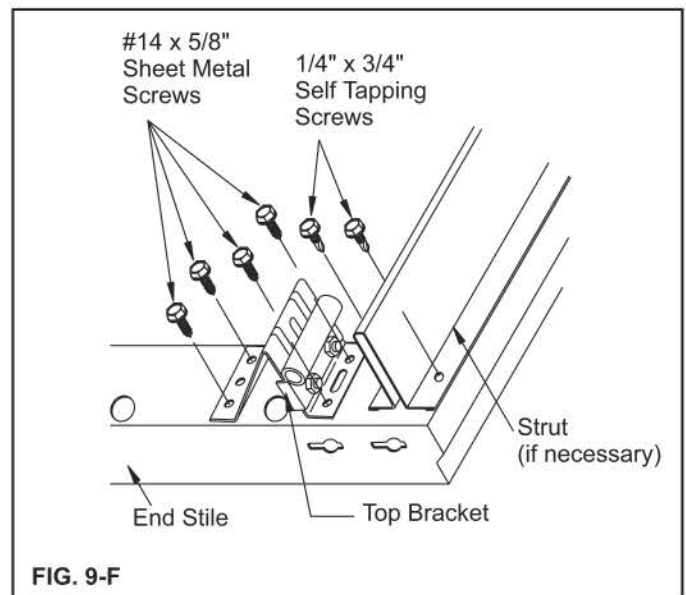

FIG. 9-F

STEP 10 - Reinforcing the Top Section for Opener

To avoid damage to your door, you must reinforce the top section of the door in order to provide a mounting point for the opener to be attached. You will need one (1), two (2), or three (3) pieces of 1-1/4" x 1-1/4" minimum punched angle at least 13 gauge or 3/32" thick from your local hardware or building supply store. Figures 10-B to 10-E show how punched angle is to be affixed to door.

Horizontal Angle Attachment

Attach the horizontal punched angle (the longer piece) to the top section as shown in Figure 10-A. Angle iron may need to be trimmed depending on door section height and distance between center stiles. Some doors with struts may not need a horizontal angle; see Figures 10-B to 10-E to identify the attachment method for your specific door.

Do NOT install the bracket supplied with the opener. Failure to reinforce the door, as illustrated, will void your warranty.

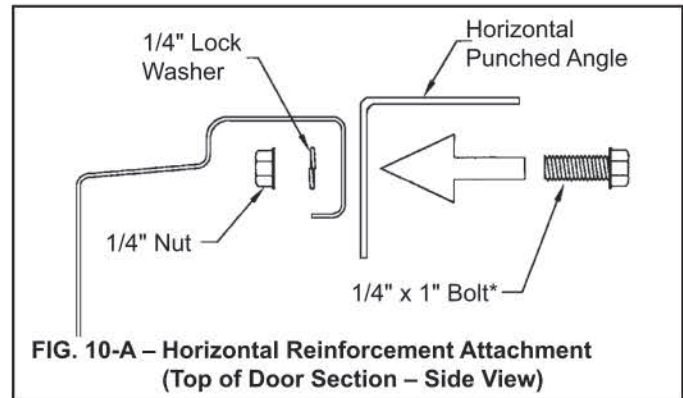
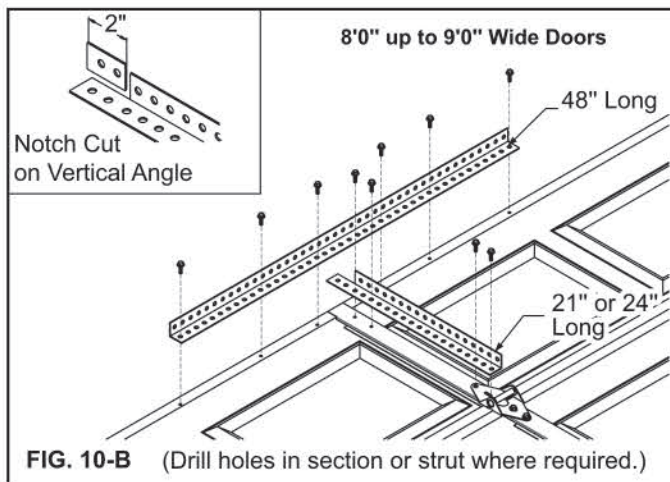

FIG. 10-A – Horizontal Reinforcement Attachment (Top of Door Section – Side View)

*Fully-insulated doors use 1/4" x 3/4" self tapping screw.

NOTE: An opener bracket kit specifically designed for opener attachment may be purchased as an option (silver galvanized or white powder coated). Instructions are provided with the kit.

NOTE: Operator may be attached up to 2 feet off center. (Doors with Torsion Springs Only)



Required materials:

- (1) 21" or 24" and (1) 48" length of angle iron,
- (6) 1/4"x1" bolts, (6) 1/4" lock washers, (6) 1/4" nuts, and
- (4) #14 x 5/8" sheet metal screws.

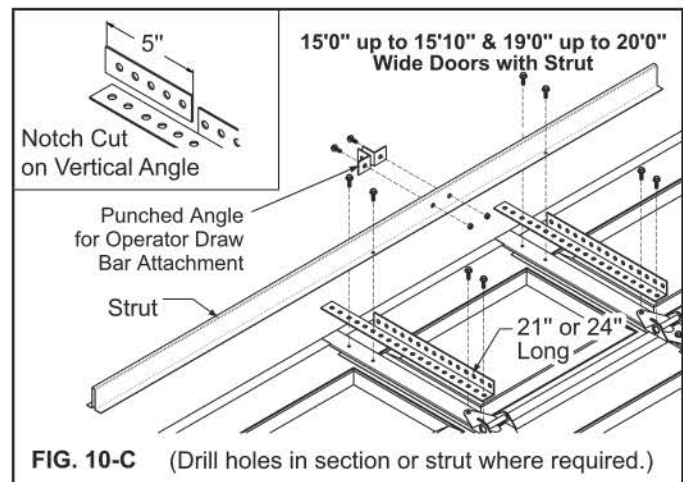

Required materials:

- (2) 21" or 24" lengths of angle iron,
- (2) 3/8"x1-1/4" bolts, (2) 3/8" lock washers, (2) 3/8" nuts,
- (4) #14 x 5/8" sheet metal screws, and
- (4) 1/4" x 3/4" self tapping screws.

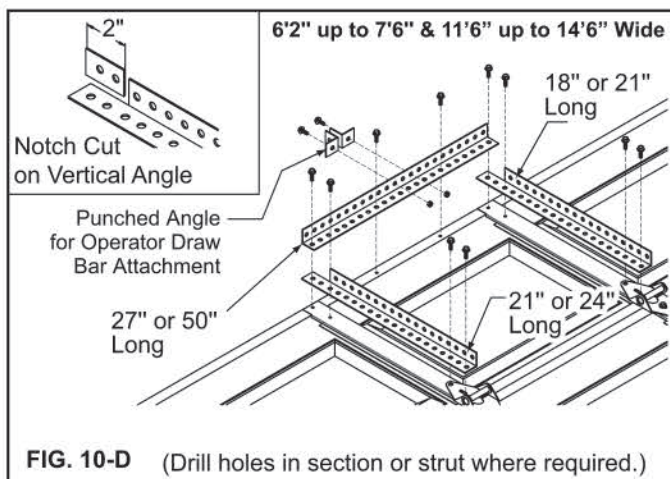

Required materials:

- (2) 21" or 24" and (1) 27" or 50" length of angle iron
- (4) 1/4"x1" bolts, (4) 1/4" lock washers, (4) 1/4" nuts, and
- (8) #14 x 5/8" sheet metal screws.

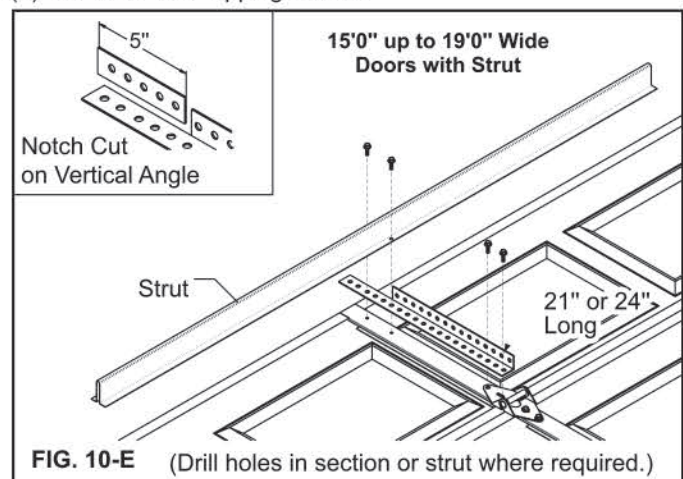

Required Materials:

- (1) 21" or 24" length of angle iron,
- (2) #14 x 5/8" sheet metal screws, and
- (2) 1/4" x 3/4" self tapping screws.

STEP 11 – Assembling and Installing the Track

Before assembling brackets to vertical track be sure to read Step 11-1 and Step 11-2. Refer to illustration for placement of brackets on track.

NOTE: Brackets may already be riveted in place. If additional adjustment is required, the rivets can be drilled out and the brackets can be reattached with track bolts and flange nuts (available through the toll-free Consumer Services number, see outside cover).



WARNING

To avoid installation problems that could result in injury or property damage, use only track provided with new door.

Step 11-1: Loosely fasten the track brackets to the vertical track using one 1/4" x 5/8" track bolt and 1/4" flange nut as shown with the head of the bolt inside the track. There are two sizes of brackets for 7' high doors, and three sizes for 8' high doors. The shortest track brackets should be installed ten inches from the bottom of the track with the flange facing the flat side of the track, one on the left and one on the right. The next larger sized pair of brackets should be installed centered on the track. If you have an 8' high door, the remaining pair of brackets should be installed ten inches from the top of the vertical track. The flat side of the track goes toward the wall. (FIG. 11-A)

Step 11-2: Loosely attach the flag bracket to the top of the track with two 1/4" x 5/8" track bolts and 1/4" flange nuts with the head of the bolts in the track. Make sure bolts and nuts are attached through the proper holes in flag bracket for your door thickness. (FIG. 11-C)

(Refer to FIG. 11-B to determine proper bolt placement.)

NOTE: If additional adjustment is required, horizontal slots in flag brackets can be used for attachment to vertical track.

Step 11-3: Place the track over the rollers on the door. Move the track close to the door so that the rollers are all the way into the hinges. Do not force the track too tightly or the door will bind. This should leave about 1/2" between the edge of the door and the track. Pilot holes of 3/16" are required at each lag screw location before installing the lag screw. Lift track about 1/2" from the floor and fasten the flag bracket and track brackets to the jamb with 5/16" x 1-5/8" lag screws. The flag bracket requires three screws, one each in the top, middle, and bottom holes. Do this for both sides of the door. When the track brackets and flag brackets are securely fastened to the jamb, tighten the track bolts and flange nuts connecting the flag brackets to the tracks. (FIG. 11-D)

NOTE: The tops of the vertical tracks must be level with each other. Check this by measuring from the top of the door sections to the top of the track on both sides. If they are not equal, cut some material off the bottom of one track to lower it or raise the other track.

Do not raise the vertical track beyond the bottom rollers on the bottom section of door.

NOTE: Do not attach any brackets directly to drywall. All track brackets, flag brackets, and spring brackets should only be attached directly to wood bucks.

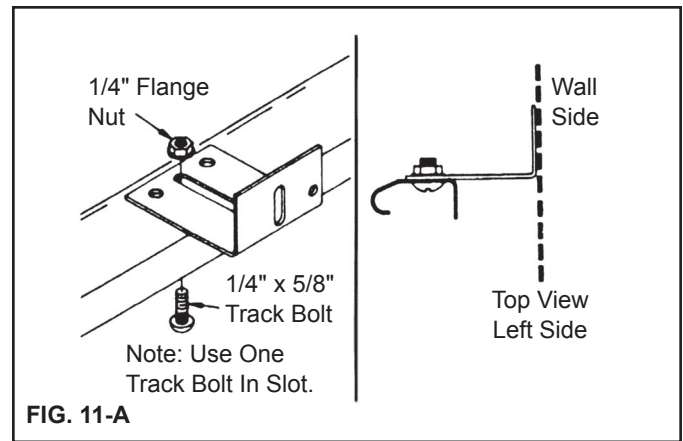

FIG. 11-A

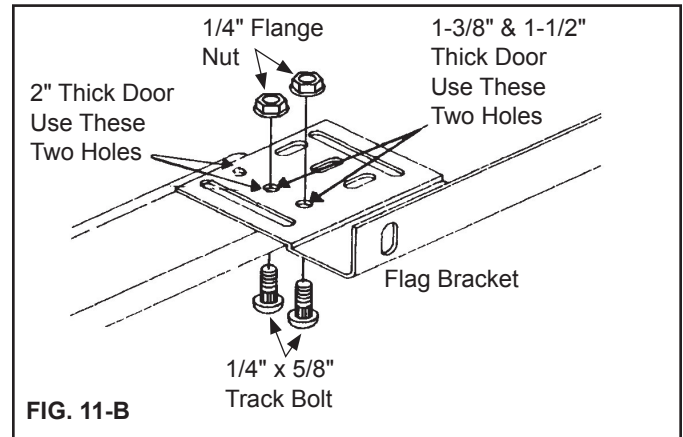

FIG. 11-B

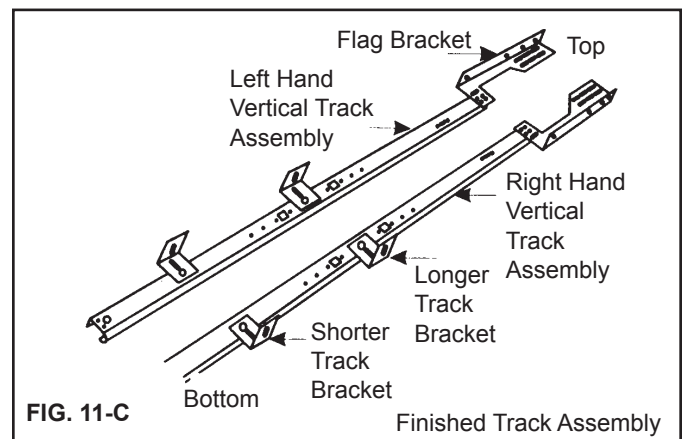

FIG. 11-C

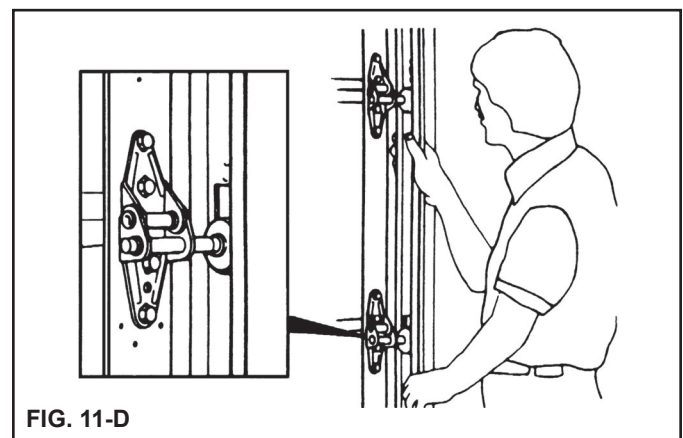

FIG. 11-D

STEP 11 - Assembling and Installing the Track (Continued)

NOTE: Pressure-treated lumber purchased after January 2004 is treated with chemicals that have highly corrosive effects on metal fasteners. The fasteners provided with your door are intended for use with standard lumber (not pressure-treated) only. If you are installing your door into an opening framed with pressure-treated lumber purchased after January 2004, two items must be changed: 1) 5/16" x 1-5/8" lag screws with a minimum galvanization equivalent to G185 must be purchased for this application, and 2) to prevent potential corrosion between lumber and track/spring components, paint either the surface of the pressure-treated lumber or those surfaces of the track and spring components that come in contact with the pressure-treated lumber.

Step 11-4: Fasten the horizontal angle to the horizontal (curved) track with two 1/4" x 5/8" track bolts and 1/4" flange nuts so that the heads of the track bolts are on the inside of the track. On some doors this angle may be 82" long and will require three additional fasteners per side. If the angle has been preassembled, skip Step 11-4 and proceed with Step 11-5. (FIG. 11-E)

Step 11-5: Temporarily support the rear end of the track with a rope from the trusses overhead in the garage or on a tall ladder. (FIG. 11-F)

Step 11-6: Place the track over the roller in the top bracket. Attach the curved end of the horizontal track to the flag bracket with two 1/4" x 5/8" track bolts and 1/4" flange nuts so that the heads of the screws are on the inside of the track. The horizontal and vertical track must join together to form a continuous channel for the rollers. Attach the end of the horizontal angle to the top of the flag bracket with a 3/8" x 3/4" carriage bolt and 3/8" hex nut. Use the top set of slots for 15" radius track, the middle set of slots for 12" radius track, and the bottom set of slots for Low Headroom track. (FIG. 11-G)

Step 11-7: Rear track hangers need to be made at this time. Use 1-1/4" x 1-1/4" punched angle, 13 gauge or 3/32" steel. These are not provided with the standard hardware. They are used to attach the rear of the horizontal track to the ceiling joist.

Enough angle iron or punched angle should be purchased to make two rear track hangers. These hangers must be strong enough to hold the full weight of the door. Attach a bolt at least 1" long through the end of each track to stop the door at the end of its travel. (FIG. 11-H)



WARNING

Sway braces must be used to prevent tracks from spreading and allowing door to fall, which could cause serious injury. Bolts placed in the end of each track (FIG. 11-H) must be at least 1" long to prevent the top section from exiting the track.

NOTE: Rear track hangers should not be mounted any farther than 6" from the end of horizontal track.

Step 11-8: Placement of rear track hangers is critical for the door to operate properly. The rear track hangers should hold the horizontal track level and square to the door. Squareness should be measured by comparing two diagonal distances: 1) the distance from the top left-hand corner of the door to the rear of the right-hand horizontal track and 2) the distance from the top right-hand corner of the door to the rear of the left-hand horizontal track. (FIG. 11-I, opposite page)

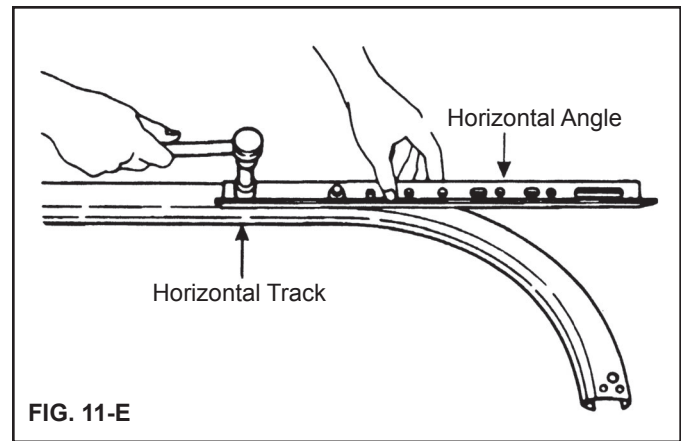

FIG. 11-E

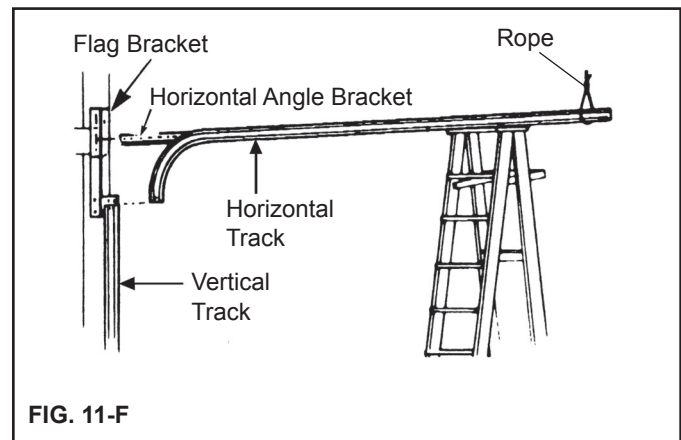

FIG. 11-F

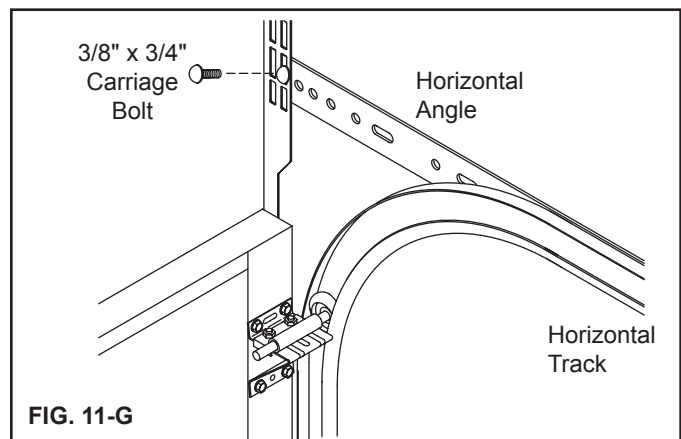

FIG. 11-G

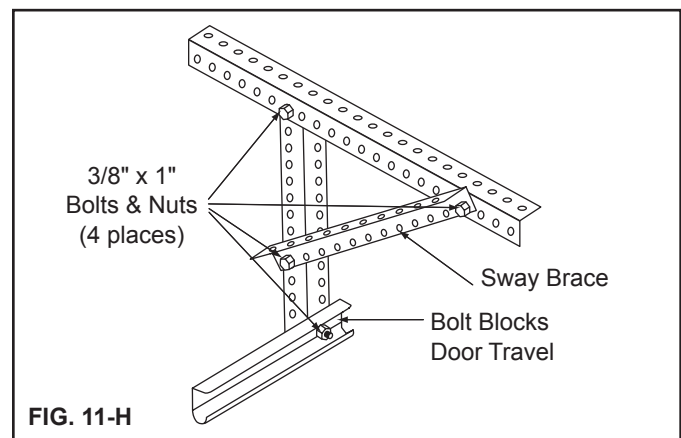

FIG. 11-H

Step 11-8, Continued: Adjust the position of the tracks if the squareness distances are not within 1/2" of each other. Horizontal track can be out of level up to 1" from front jamb to rear track hanger. (FIG. 11-I)

When the track is square and level with the opening, the track hangers can be fastened permanently to the ceiling trusses. Three 5/16" x 1-1/2" lag screws are recommended. Be sure 3/16" pilot holes are drilled before installing 5/16" lag screws. The attachment must be strong enough to hold the weight of the door.



WARNING

Use adequate length screws to fasten rear track hangers into trusses. Door may fall and cause serious injury if not properly secured.

Step 11-9: With the track installed, the top door section can now be properly adjusted. With the slide on the top bracket loose, force the top of the door against the stop molding or door jamb. Pull the roller towards you so it is tight against the groove in the track and tighten the slide bolts. (FIG. 11-J)

At this time, remove the 3" nails that were used to hold sections in place prior to installation of the track assembly. (Refer back to FIG. 9-B.)

STEP 12 – Lock Installation (If Included)

Keyed Lock:

If your door has an exterior keyed lock, please complete the installation of the lock at this time following the instructions provided with your lock hardware. If your door has a slide bolt lock, install according to the instructions below.

Slide Bolt:

The inside slide bolt is installed on the end stile of the second section using (4) #14 x 5/8" hex head sheet metal screws (steel doors) or (4) 1/4" x 1" lag screws (wood doors). (FIG. 12-A)

NOTE: 3/16" holes may have to be predrilled before installing screws.

The slide bolt rests against the top of one of the rectangular engaging slots in the vertical track. Proper alignment is easier to achieve by using track as a guide.

NOTE: It may be necessary to knock out the slug in the vertical track to open the slot for lock engagement. Remove slug by striking with a hammer from the outside of the track.

IMPORTANT: If your door is going to be equipped with an automatic garage door opener, make sure that the door is always unlocked when the opener is being used. This will avoid damage to the door.

STEP 13 – Pull Rope (Manually Operated Doors Only)

To complete the door section installation, tie the pull rope provided to the bottom roller shaft. (FIG. 13-A)

STEP 14 – Spring Installation

It is now time to install the spring. Proceed to springing instructions that came with your spring hardware.

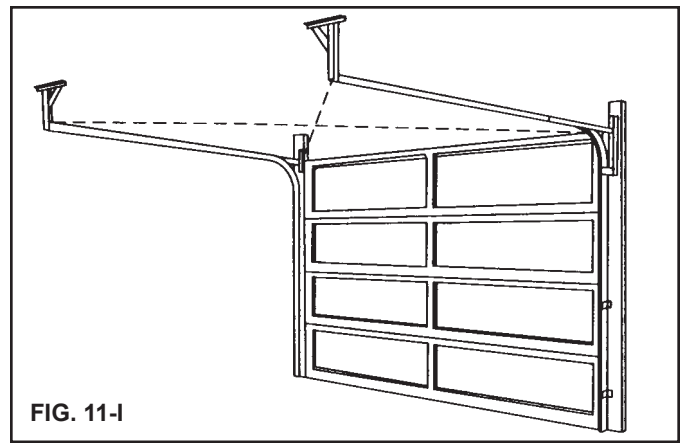

FIG. 11-I

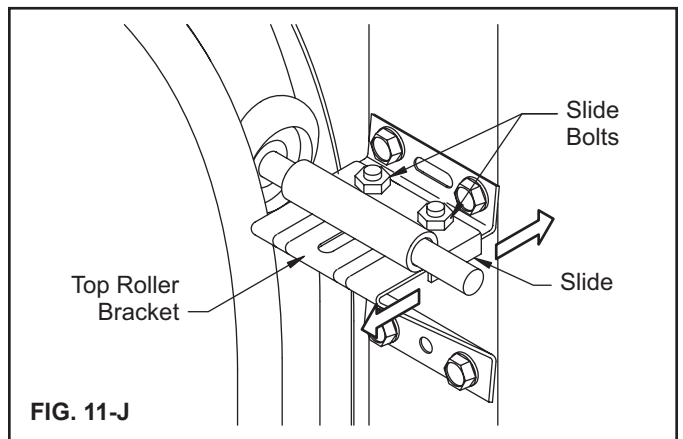

FIG. 11-J

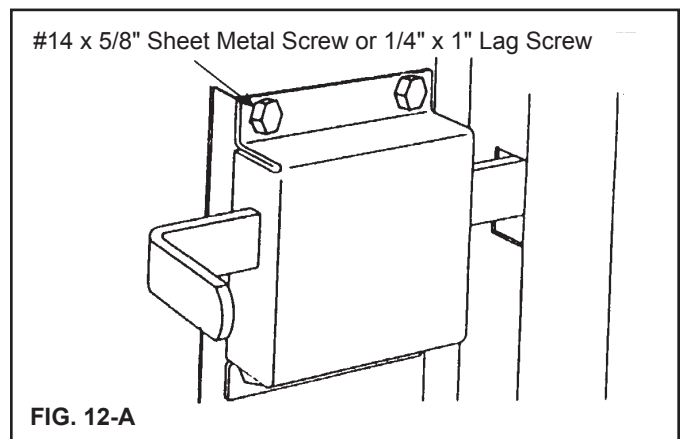

FIG. 12-A

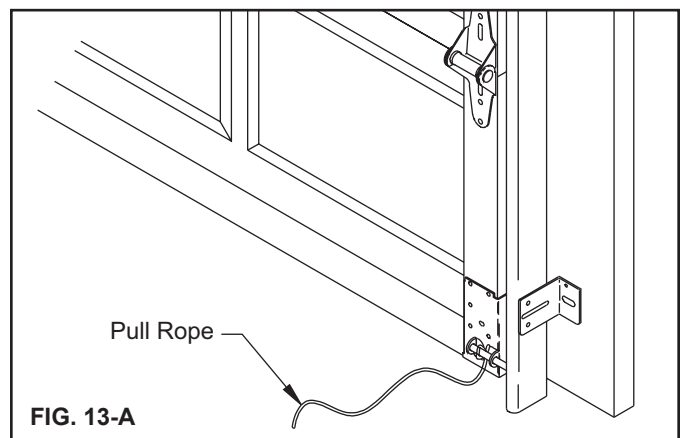

FIG. 13-A

STEP 15 – Attaching an Automatic Opener

IMPORTANT: To avoid damage to your door, you must reinforce the top section of the door in order to provide a mounting point for the opener to be attached. Refer to the section of this manual titled Reinforcing the Top Section on page 14 for specific instructions. Failure to reinforce the door as illustrated will void the warranty on your door.



WARNING

To avoid risk of strangulation or personal injury to children, if your door has a pull rope, you must remove the pull down rope when you install an automatic garage door opener.

IMPORTANT: When installing an automatic garage door operator, make sure to follow manufacturer's installation and safety instructions carefully. **Remove the pull down rope and unlock or remove the lock.** If attaching an operator bracket to the wooden anchor pad, make sure the wood anchor pad is free of cracks and splits and is firmly attached to the wall. Always drill pilot holes before attaching lag screws.

The operator arm will usually be attached to the vertical reinforcement member at roughly the same height as the top roller of the door. Attach the opener arm to the reinforcement as shown in Figures 15-B to 15-D. To prevent the top of the door from bending, the opener rail should be mounted no less than 2" and no greater than 5" from the face of the door with the door in the open position (FIG. 15-A). Additionally, when the door is closed, the portion of the operator arm attached to the door should be at angle of approximately 60 degrees from the vertical (FIG. 15-B).

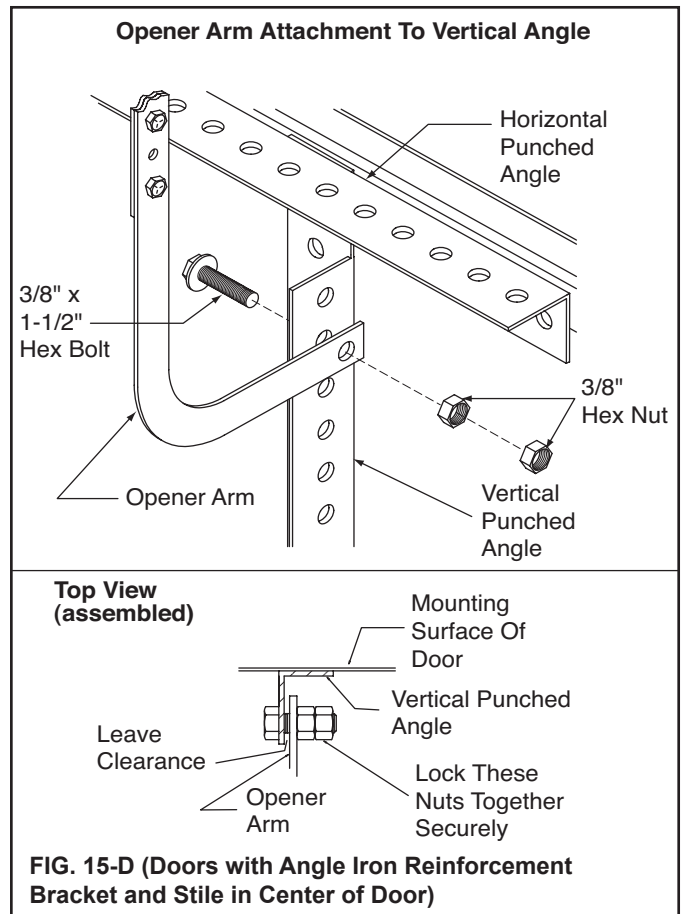
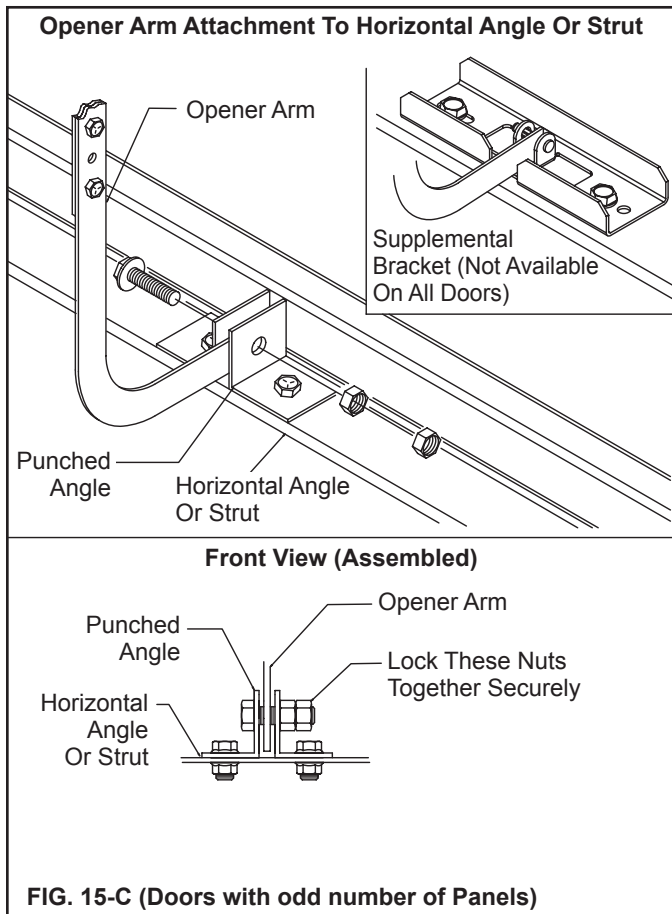
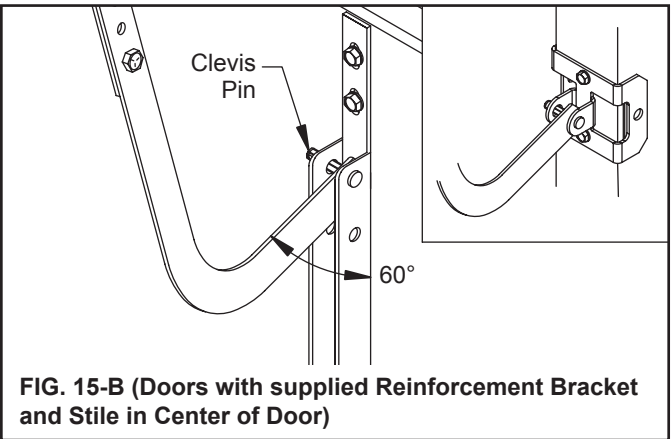
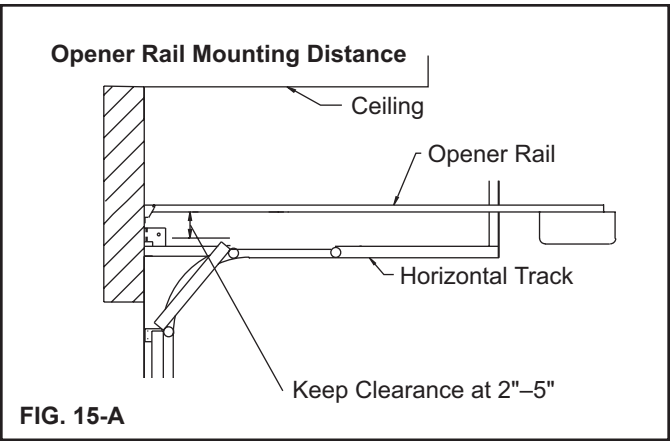

Painting your Door

Painting: Your steel garage door can be painted with a high quality 100% acrylic latex (flat, satin, or semigloss) exterior grade paint. Before painting the door it must be free of dirt, oil, caulk, waxes and mildew.

Do not use any type of oil based paint or Alkyd modified acrylic latex paint. These paints will void the warranty of your door.

Painting preparation: Clean surface first with a diluted solution of Trisodium Phosphate. The recommended concentration is 1/3 cup of powder to 1-1/2 to 2 gallons of water. A cleaning pad (3M Synthetic steel wool GRAY not green) should be used saturated with this cleaning solution. Rub with even pressure to lightly scuff the surface while applying the cleaning solution over all surfaces to be painted. A final wipe and rinse with clean water and sponge should be done to remove any loose material. Change water often to ensure clean rinse and allow to dry. Pre test your paint on a small area (see paragraph **Paint** below). If the paint shows signs of poor adherence, (tape test below) there may be a problem with the paint or the surface preparation. **DO NOT PROCEED!** A new paint or further preparation of the surface is called for.

Alternate cleaning compounds: Areas of the country that do not carry Trisodium Phosphate can use a biodegradable cleaner with the cleaning pad above. Follow above directions to rinse completely and pre test paint.

NOTE: Sanding could remove rust-inhibiting compounds, therefore, sanding should be done only to damaged areas where bare metal has been exposed. Refer to the "Paint Repair" section of these instructions.

Paint Repair: Should your door's paint finish become damaged, exposing the bare metal, it will become necessary to repair this area to prevent rust from forming. The damaged area should be lightly sanded with a medium to fine sandpaper making sure to remove all visible red and white rust. Wipe this area with a dry, clean rag. Coat the sanded area with a high quality, rust inhibiting, zinc enriched primer. This type of primer can be found at most paint or hardware stores, and should be labeled for covering bare and galvanized steel. Once the primer is applied, wait the time specified on the primer's instructions before you finish painting your door.

Paint: Your steel garage door can be painted with a high quality, 100% acrylic latex (flat, satin, or semigloss) exterior grade paint. Since all paints are not created equal, the following test needs to be performed: paint should be applied on a small area of the door (following the instructions on the paint container), allowed to dry, and evaluated prior to painting the entire door. Paint defects to look for are blistering and peeling. An additional test is to apply a strip of masking tape over the painted area and peel back, checking to see that the paint adheres to the door and not to the tape.

After satisfactorily testing a paint, follow the directions on the container and apply to the door. Be sure to allow adequate drying time should you wish to apply a second coat. Window frames & inserts can be painted with a high quality, 100% acrylic latex. The plastic should first be lightly sanded to remove any surface gloss.

NOTE: Do not apply paint when door surface temperature is different from manufacturer's suggested temperature range for application.

Snap-In Grille Removal And Replacement:

NOTE: DO NOT REMOVE SCREWS from the window frame. Decorative grilles are designed to snap-in and out of the window frame.

Some doors with windows have a decorative grille attached in front of the window. The grille can be removed for cleaning or painting purposes.

- 1) Remove the tabs on the vertical legs of the grille (two on short panel windows, six on long panel windows) from the notches in the front window frame.
- 2) The grille can be firmly pulled out of the window.
- 3) Replacing the grille is the reversal of the process described for removal. The two or six longer tabs on the vertical legs of the grille must be placed in the notches under the lip of the front window frame. The two shorter tabs on the horizontal leg of the grille must be placed under the lip of the front window frame.

Glass Replacement



WARNING

To avoid injury, use extreme caution in handling glass window pane. When the frame is removed, the exposed steel edge of the door may be sharp. Avoid contact with the steel edges.

Glass Replacement: If your door is equipped with windows and the glass should need replacement, follow the steps below:

- 1) With someone holding the outside frame, remove the screws from the inside window frame.
- 2) Pull the inside frame out of the door.
- 3) Carefully remove the broken or old glass.
- 4) Insert the new glass. The glass should be 17-5/8" x 14-1/16" (short panel windows) or 40-1/8" x 14-1/16" (long panel windows). See illustration below for glass dimensions of single or double arched windows. (FIG. Glass-1)
- 5) With someone holding the outside frame, reinsert the screws into the inside frame, trapping the glass.

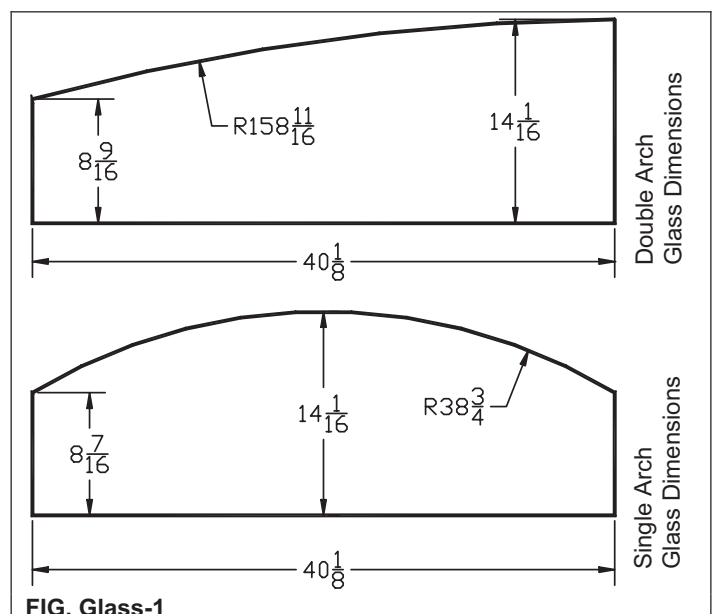

Annual Maintenance

- 1) Lubricate all moving parts of the door with light household oil, including:
 - a) Lift cables at the bottom bracket button
 - b) Bearing of the sheaves
 - c) Lock hardware where surfaces turn or slide
 - d) Full length of torsion spring to reduce friction between coils
 - e) Lubricate steel rollers. **DO NOT** lubricate nylon rollers.
- 2) Check for loose or bent hinges.
 - a) Tighten loose hinges.
 - b) Straighten or replace bent hinges.

Caution: To replace bent hinge(s) or broken roller(s):

Door must be locked and in the down position.

No more than 1 hinge is to be removed from the door at any given time.

Under no circumstances should you loosen or remove the bottom bracket without disengaging the spring tension. (Follow instructions for removing extension springs.)

- 3) Check roller for broken wheels, bent shafts, or worn out bearings
- 4) Check the door and track supports for loose or missing bolts, screws, etc. Be careful not to over tighten.
- 5) Check the extension cables. Are they running properly in the sheaves? Check for wear of the cable at the bottom bracket button.
- 6) Check for bent track. If bent, call an authorized professional dealer.
- 7) Extension spring hardware, including springs, cables, sheaves, sheave forks, bottom brackets, and containment cables, should be adjusted or repaired only when the spring tension is released (the door must be open). These repairs should be made by a qualified door technician or a mechanically experienced person with proper tools and instructions.
- 8) If your door has torsion springs, the spring assembly and wood anchor pad should only be adjusted or repaired by a professional door technician.

Cleaning the Door

In order to prevent damage (rusting) caused by foreign matter adhering to the door, the door should be cleaned at least twice a year (normal environments) or 4 times a year (coastal environments). The door may need to be cleaned more frequently if road salt accumulates in a winter climate. The door should be wiped down with a mild household detergent and rinsed with clear water.

NOTE: Be sure to clean behind the stop molding on the sides and top of door.

Waxing the Door (Coastal and Harsh Environments)

For coastal and harsh environments, it will be necessary to wax the front side of the door following installation. Select a good quality car wax and apply according to wax manufacturer's instructions. Wax should be applied at least twice a year, immediately after cleaning (see cleaning instructions above).

Glass Windows Cleaning and Care Instructions

Clean with a mild solution of a dishwashing detergent and a soft cloth. After cleaning, rinse thoroughly. DO NOT use any ammoniated, abrasive, or solvent-based cleaners of any kind.

Replacement Parts

Replacement parts are available from an authorized professional dealer or a building supply retailer. When ordering repair parts, always provide the following: part name, model number, and door width and door height (W x H). For the location of the authorized professional dealer or a building supply retailer nearest you, please write or call:

Clopay Building Products
Consumer Services Dept.
1400 West Market Street
Troy, OH 45373 USA

Call Toll Free: 1-800-225-6729
Hours of Operation (EST):
Monday – Friday, 8:30 AM - 7 PM
Saturday 8:30 AM - 5 PM.

MISSING ANY PARTS?

PLEASE CALL TOLL FREE: (800-225-6729)
PARTS WILL BE REPLACED PROMPTLY

DO NOT RETURN DOOR TO STORE

(Stores Do Not Carry Spare Parts)

IMPORTANT – Information Needed When Calling:

- 1) Model number and size of door (Located on packaging)
- 2) Spring Type (Extension, EZ-Set® Extension, EZ-Set® Torsion or Standard Torsion)
- 3) Store city and state of purchase
- 4) Contract # or serial number if special order