



deluxe aluminum FULL VIEW DOORS



Model 903 with insulated glass and bottom insulated aluminum panel, powder coated frame



FEATURES

- 2-1/8" (54 mm) thick construction, 6063-T5 extruded aluminum alloy with integral reinforcing fin for maximum durability.
- Exclusive, capped rail construction helps seal out the elements and adds to door durability.
- Tongue-and-groove meeting rail.
- Standard finishes in high luster clear anodized or prepainted white or brown to complement most building designs. Powder coating available.
- Variety of glazing options and panel designs available to customize a door to your architectural or application requirements.
- Ideal for car washes, service stations, fire houses and other applications where highlight transmission and visibility are required.
- Model 902 product features 44" (1.1 m) on center panel spacing with limited glazing options. Model 903 is fully customizable and features equal panel spacing.

deluxe aluminum FULL VIEW DOORS

Quality Assurance – Doors shall be aluminum sectional overhead type as manufactured by Clopay Building Products Company. Each door is provided as one complete unit including sections, brackets, tracks, counterbalance mechanisms and hardware (list options) to suit the opening and headroom available.

Materials and Construction – Sections to be 2-1/8" (54 mm) thick (6063-T5) anodized or prepainted extruded aluminum with reinforcing integral fin. Vertical end stiles and center stiles are fastened together with rails by a full-length galvanized steel 5/16" (7.9 mm) threaded rod and flange nuts. Enclosed top rails to be 3-1/2" (88.9 mm) wide and bottom rails to be 3-1/2" (88.9 mm) or 4-1/2" (11.4 cm) as required. Meeting rails to be 2-13/16" (71.4 mm) wide and end stiles 3-1/2" (88.9 mm) wide. Meeting rails to form a tongue-and-groove joint. Model 903 panels are equal width across the section. Panel options include .050" (1.3 mm) anodized or prepainted aluminum, 1/2" (12.7 mm) insulated, 1/8" (3.2 mm) plexiglass, 1/4" (6.4 mm) polycarbonate, 1/8" (3.2 mm) DSB and 1/4" (6.4 mm) wire glass. Panels or glass are sealed with a hot melt adhesive and secured with a locking retainer. Glazing or aluminum panels are preinstalled and shipped as one complete unit. Astragal to be U-shape PVC vinyl.

Hardware – 10-ball bearing steel rollers to be full floating in case-hardened steel races, mounted to fit the taper of the track. Roller hinges to be minimum 14 gauge and top and bottom brackets to be minimum 12 gauge galvanized steel.

Tracks – 2" (50.8 mm) and 3" (76.2 mm) track as required. Vertical tracks to be a minimum of 16 gauge galvanized steel tapered and mounted for wedge type closing. Horizontal tracks to be minimum 14 gauge galvanized steel reinforced with minimum 13 gauge galvanized angles as required. 3" (76.2 mm) tracks are 12 gauge.

Spring Counterbalance – Door assembly to be operated by a torsion spring counterbalance mechanism, with a helically wound, oil tempered torsion spring mounted on a galvanized steel tube or solid steel shaft as required. Cable drums are die cast aluminum. Lift cables are high strength, galvanized aircraft cable with minimum 7:1 safety factor.

Locking – Inside spring loaded slide bolt lock on end stile shall engage slot in track.

Wind Loading – Door shall comply with ANSI/DASMA 108 or to meet specific application requirements.

Panel Spacing – Model 902 panels are 44" (1.1 m) on center with end panels smaller than center panels. Model 903 features equal panel spacing.

GLAZING OPTIONS

| Glazing Material | Standard Sizes Available | Standard Colors Available | Aluminum Panel |
|----------------------|--------------------------------------|--|---|
| 1/8" DSB Glazings | Up to 22'2" x 18' | White, Brown & Clear Anodized Aluminum | .050" Anodized or Prepainted Aluminum |
| 1/8" Plexiglass | Up to 24'2" x 18' | White, Brown & Clear Anodized Aluminum | .050" Anodized or Prepainted Aluminum |
| 1/2" Insulated Glass | Up to 20'2" x 18' | White, Brown & Clear Anodized Aluminum | Polystyrene Sandwiched Between (2) .050" Anodized or Prepainted Aluminum Sheets |
| 1/4" Wire Glass | Up to 20'2" x 18' | White, Brown & Clear Anodized Aluminum | .050" Anodized or Prepainted Aluminum |
| 1/4" Polycarbonate | Up to 24'2" x 18' | White, Brown & Clear Anodized Aluminum | .050" Anodized or Prepainted Aluminum |
| Custom | Varies Depending on Glazing Material | Custom Available | Varies Depending on Glazing Material |

OPTIONS

- A. Glazing** – 902: 1/2" (12.7 mm) insulated, 1/2" (12.7 mm) insulated tempered, 1/8" (3.2 mm) tempered. 903: 1/2" (12.7 mm) insulated, 1/2" (12.7 mm) insulated tempered, 1/4" (6.4 mm) tempered, 1/8" (3.2 mm) plexiglass, 1/4" (6.4 mm) wire glass, 1/8" (3.2 mm) DSB glass, 1/4" (6.4 mm) polycarbonate and custom options available.
- B. Track** – Vertical lift, follow-the-roof slope, high lift and low headroom track available. 2" (50.8 mm) and 3" (76.2 mm) tracks as required.
- C. Exhaust Ports** – Available in bottom aluminum panel.
- D. Finishes** – High luster, clear anodized, or prepainted white, brown or bronze standard; medium bronze or black anodized, powder coat paint optional.
- E. Mullions** – Carry-away and roll-away available on doors to 14' high (4.3 m) [2" (50.8 mm) track only]. Swing-away available on doors to 20' high (6.1 m) [2" (50.8 mm) and 3" (76.2 mm) track].
- F. Weatherstripping** – Complete perimeter seals available in various materials.

PANEL ARRANGEMENT

| Door Width | Number of Panels |
|----------------|------------------|
| Up to 9'2" | 2 |
| 9'4" to 13'2" | 3 |
| 13'4" to 16'2" | 4 |
| 16'4" to 20'2" | 5 |
| 20'4" to 24'2" | 6 |

SECTION ARRANGEMENT

| Door Height | Number of Sections |
|----------------|--------------------|
| Up to 8'0" | 4 |
| 8'3" to 10'0" | 5 |
| 10'3" to 12'0" | 6 |
| 12'3" to 14'0" | 7 |
| 14'3" to 16'0" | 8 |
| 16'3" to 18'0" | 9 |

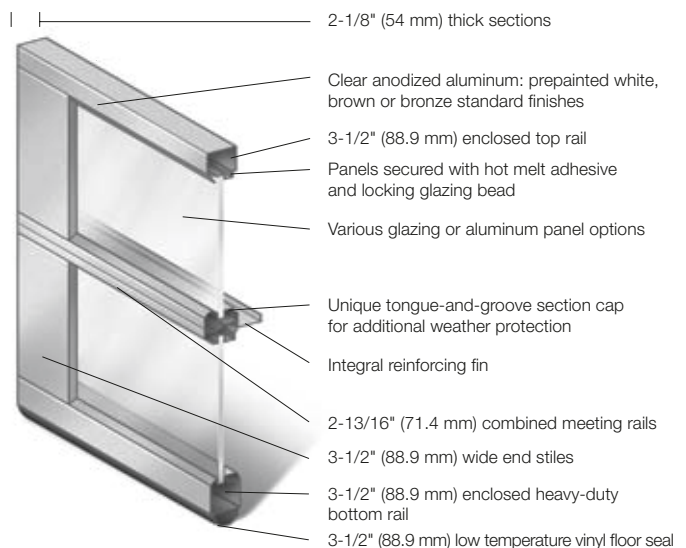

DISTRIBUTED BY:

For special applications and options, consult Commercial Information Assistance (CIA) at 1-800-526-4301.



For more information on these and other Clopay products, call 1-800-526-4301 or visit www.clopaycommercial.com

