

MODEL DS140
HEAD CAP TYPE
DOCK SEAL

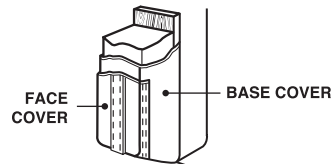

REINFORCED FACE

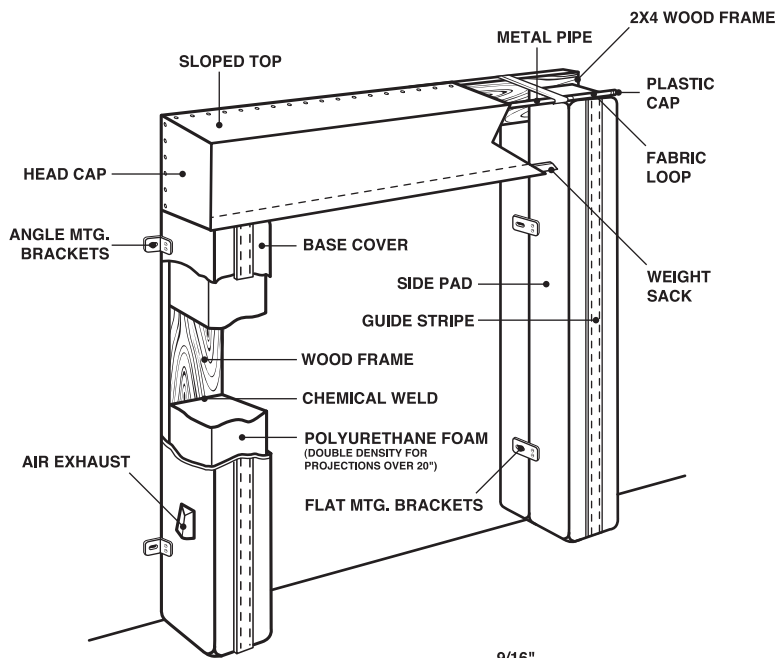
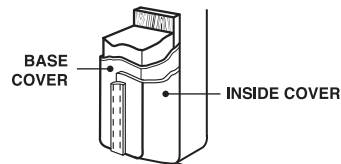

REINFORCED INSIDE

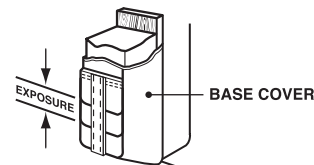

ARMOR PLEATS

- 4" EXPOSURE
- 8" EXPOSURE
- 16" EXPOSURE

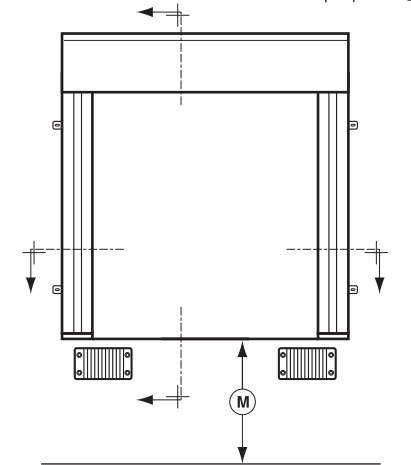
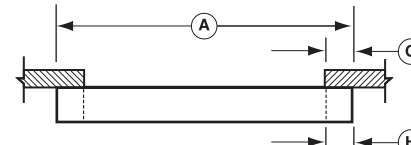
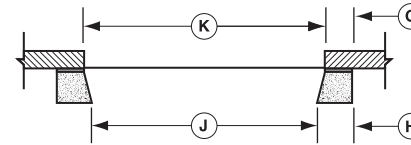

BEVELED SIDE PADS

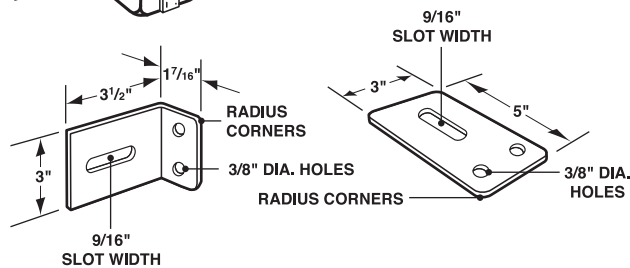
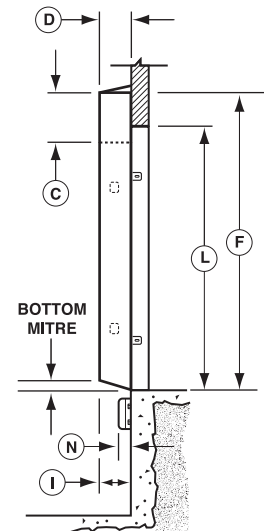

ANGLE AND FLAT MOUNTING BRACKETS

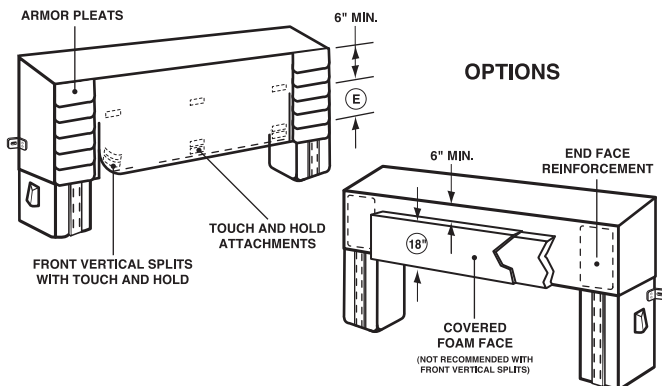

OPTIONS

HEAD CAP DATA

- ___ "A" WIDTH
- ___ "C" HEIGHT AT FACE
- ___ "D" TOTAL PROJECTION
- ___ BASE FABRIC
- ___ COLOR

- END FACE REINFORCEMENT
 - ___ FABRIC
 - ___ COLOR
- ARMOR ENDS
 - ___ FABRIC
 - ___ COLOR
 - ___ "I" PLEAT EXPOSURE
- FRONT VERTICAL SPLITS
 - ___ "E" SPLIT HEIGHT (C-6"= MAX. SPLIT)

- TOUCH AND HOLD ATTACHMENT
- ROPE/PULLEY SYSTEM

- COVERED FOAM FACE
 - 4" THICK X 18" HIGH X
 - "J" SIDE PAD FACE I.D.

SIDE PAD DATA

- ___ "F" LENGTH AT REAR
- ___ "G" WIDTH AT REAR
- ___ "H" WIDTH AT FACE
- ___ "D" TOTAL PROJ. AT TOP
- ___ "I" TOTAL PROJ. AT BOTTOM
- ___ "J" SIDE PAD FACE I.D.
 - ___ BASE FABRIC
 - ___ COLOR

- BLOCKOUT (IF REQUIRED)
 - PROJ: ___ TOP ___ BOTTOM
 - ___ FABRIC
 - ___ COLOR

- FACE REINFORCEMENT
 - ___ FABRIC
 - ___ COLOR

- INSIDE EDGE REINFORCEMENT
 - ___ FABRIC
 - ___ COLOR
- ARMOR PLEATS
 - ___ FABRIC
 - ___ COLOR
 - ___ "PLEAT EXPOSURE
- FORMED STEEL BACK
 - PAINTED GALVANIZED
- NON-ROT BACK

GENERAL INFORMATION

- ___ "K" DOOR WIDTH
- ___ "L" DOOR HEIGHT
- ___ "M" DOCK HEIGHT
- ___ "N" DOCK BUMPER/LEDGE COMBINED PROJECTION

- DRIVE APPROACH:**
- LEVEL DECLINED INCLINED

FB-___ QTY. ___ SHEET ___ OF ___



8585 DUKE BLVD.
MASON, OH 45040
800-526-4301
VISIT US AT WWW.CLOPAYCOMMERCIAL.COM

JOB: _____

LOCATION: _____

CONTRACTOR: _____ ARCHITECT: _____

APPROVED BY SIGNATURE: _____