EZ-Set Torsion Spring System™

Assembly Installation Instructions

EZ-Set Torsion Spring System™ Assembly Installation Instructions

These instructions are to be used in conjunction with your standard installation manual. Follow the manual up through “Assembling & Installing the Track” — except **leave a minimum of 1/2" per side between track and door**, and just loosely (temporarily) attach 3/8"-16 x 3/4" carriage bolt in flag bracket.

Please read and understand these instructions completely before proceeding with the installation of the EZ-Set Torsion Spring System™. Carefully follow these instructions to avoid personal injury or property damage.

Use these instructions for the **EZ-Set Torsion Spring System™** only. (If you have regular torsion springs, extension springs, or the EZ-Set Extension Spring System™ see the standard Installation Manual.)

Tools Needed







- 3/8" Medium duty reversible power drill
- 3/8" Open end wrench
- 3/16" Hex wrench
- 1/8" Drill bit
- 1/4" Insert bit (included)



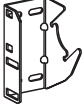



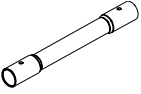

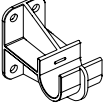
In the interest of safety this symbol means WARNING or CAUTION. Personal injury and/or property damage may occur unless instructions are followed carefully.

ALL REFERENCES TO LEFT HAND AND RIGHT HAND ARE MADE ASSUMING THAT YOU ARE INSIDE THE GARAGE LOOKING OUT.

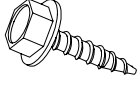
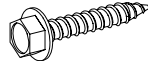
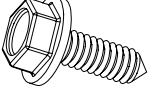
Parts List

DESCRIPTION		DOOR TYPE	QTY.
	WINDING UNIT	Sngl. Car, Sngl. Spring	1
		Dbl. Car, Sngl. Spring	1
		Dbl. Car, Dbl. Spring	2
	BRACKET	Sngl. Car, Sngl. Spring	2
		Dbl. Car, Sngl. Spring	2
		Dbl. Car, Dbl. Spring	2
	DRUMS	Sngl. Car, Sngl. Spring	2
		Dbl. Car, Sngl. Spring	2
		Dbl. Car, Dbl. Spring	2
	TORSION TUBE (Full Length) (If so equipped)	Sngl. Car, Sngl. Spring	1
		Dbl. Car, Sngl. Spring	1
		Dbl. Car, Dbl. Spring	1
	TORSION TUBE (Half Length) (If so equipped)	Sngl. Car, Sngl. Spring	2
		Dbl. Car, Sngl. Spring	2
		Dbl. Car, Dbl. Spring	2
	TUBE COUPLER (If so equipped)	Sngl. Car, Sngl. Spring	1
		Dbl. Car, Sngl. Spring	1
		Dbl. Car, Dbl. Spring	1
	END BEARING SUPPORT	Sngl. Car, Sngl. Spring	1
		Dbl. Car, Sngl. Spring	1
		Dbl. Car, Dbl. Spring	—
	CENTER SUPPORT	Sngl. Car, Sngl. Spring	—
		Dbl. Car, Sngl. Spring	1
		Dbl. Car, Dbl. Spring	1

DESCRIPTION		DOOR TYPE	QTY.
	LEFT SIDE TORSION SPRING	Sngl. Car, Sngl. Spring	1
		Dbl. Car, Sngl. Spring	1
		Dbl. Car, Dbl. Spring	1
	RIGHT SIDE TORSION SPRING	Sngl. Car, Sngl. Spring	—
		Dbl. Car, Sngl. Spring	—
		Dbl. Car, Dbl. Spring	1
	LAG SCREW 1/4" X 1"	Sngl. Car, Sngl. Spring	2
		Dbl. Car, Sngl. Spring	2
		Dbl. Car, Dbl. Spring	2
	LAG SCREW 5/16" X 1 5/8"	Sngl. Car, Sngl. Spring	4
		Dbl. Car, Sngl. Spring	4
		Dbl. Car, Dbl. Spring	4
	SHEET METAL SCREW #14 X 5/8"	Sngl. Car, Sngl. Spring	2
		Dbl. Car, Sngl. Spring	2
		Dbl. Car, Dbl. Spring	2
	CARRIAGE BOLT 3/8" - 16 X 3/4"	Sngl. Car, Sngl. Spring	4
		Dbl. Car, Sngl. Spring	4
		Dbl. Car, Dbl. Spring	4
	FLANGE NUT 3/8" X 16	Sngl. Car, Sngl. Spring	4
		Dbl. Car, Sngl. Spring	4
		Dbl. Car, Dbl. Spring	4
	TUBE RETAINER	Sngl. Car, Sngl. Spring	2
		Dbl. Car, Sngl. Spring	2
		Dbl. Car, Dbl. Spring	2

NOTE: Doors greater than 10 feet in width are double car doors.

NOTE: If you are missing any parts from the parts list, do not return it to the store. Please call the consumer support number listed on the front page of your standard installation manual.

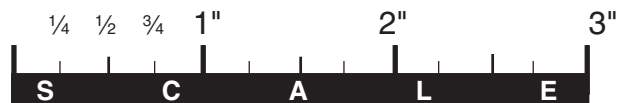

Installing The EZ-Set Torsion Spring System™

Step 1

Attach the bracket to the flag bracket and the horizontal angle with a $\frac{3}{8}$ "-16 x $\frac{3}{4}$ " carriage bolt and $\frac{3}{8}$ " flange nut. (FIG. 1, VIEW A) Be sure to orient the carriage bolt and flange nut as shown in Figure 1, Views A and B. Remove and reattach the existing $\frac{3}{8}$ "-16 carriage bolt as required. The bracket should be up against the jamb and the flag bracket. If your door is 2" thick the carriage bolt should be fastened through the slot in the flag bracket furthest from the jamb. If your door is $1\frac{3}{8}$ " thick the carriage bolt should be fastened in the slot closest to the jamb. If you have double track low headroom, see Figure 2 for carriage bolt mounting locations. Do this for both the left and right sides.

NOTE: Before installing $\frac{5}{16}$ " lag screws, it is important to drill $\frac{3}{16}$ " pilot holes where the lag screws are to be attached.

Use two $\frac{5}{16}$ " x $1\frac{5}{8}$ " lag screws to connect the brackets securely to the jamb or the header. (FIG. 1, VIEW B) Install the lag screws in the slots closest to the flag bracket if possible. Before proceeding to Step 2, make sure the carriage bolt(s) and the lag screws are fastened securely and the bracket is seated against the jamb and the flag bracket. Do this for both the left and right sides. Solid attachment is critical since these brackets will be under strong spring tension.

NOTE: If your torsion tube is one full-length piece skip to Step 3.

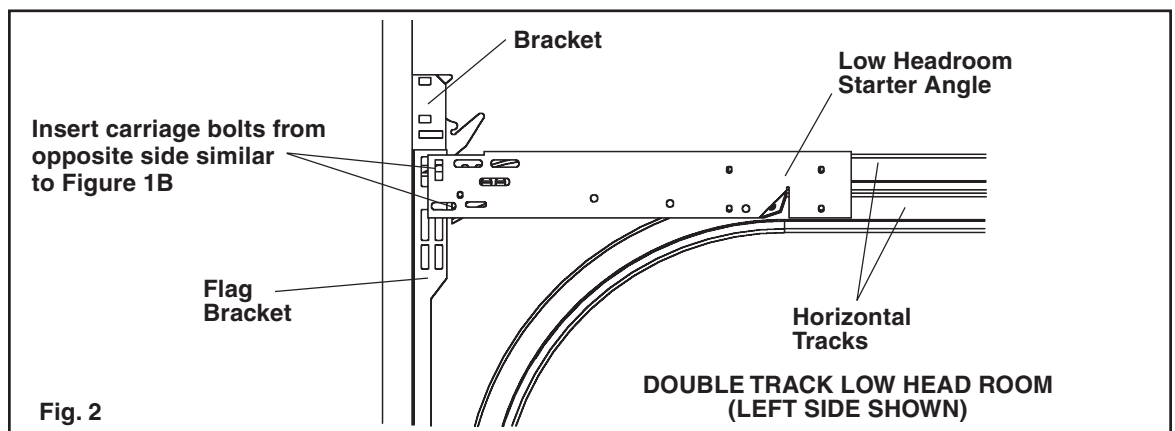
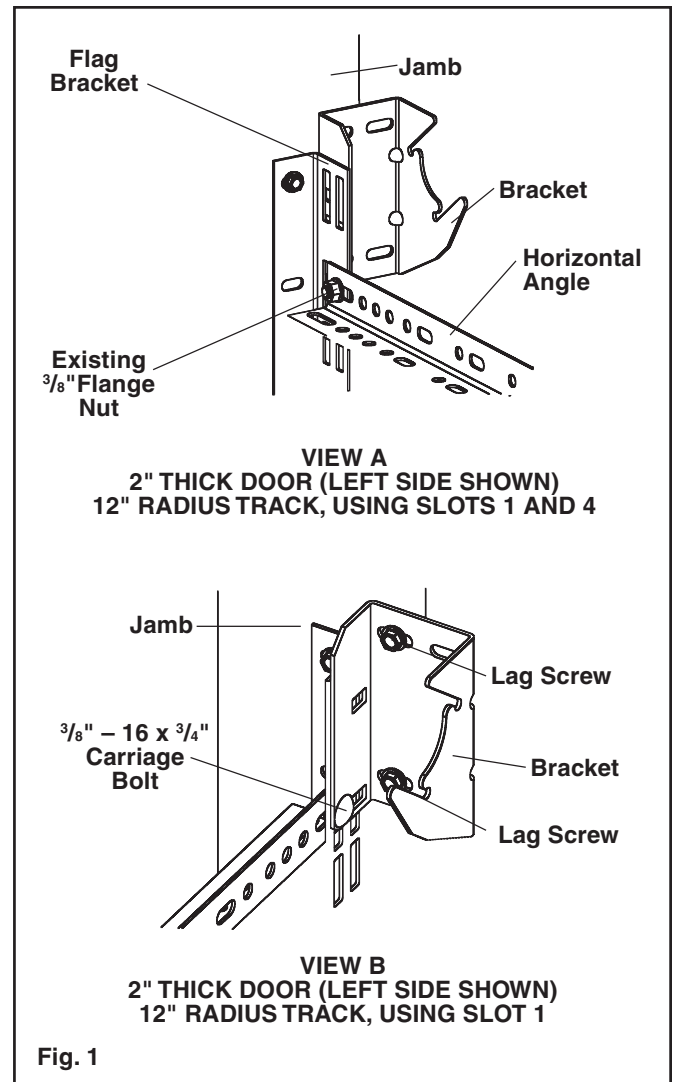

NOTE: Refer to standard instruction manual to determine the radius of your track.

Step 2

Push the two torsion tube sections firmly into the coupler.

NOTE: There are sets of two opposing holes in each end of the coupler. When attaching the coupler to each tube be sure to use the two holes that are on the same side of the coupler as shown in Figure 4.

After the tubes are inserted completely into the coupler, drill one $\frac{3}{16}$ " pilot hole in each torsion tube using the coupler holes as a guide. Fasten the coupler to the tube with (2) #14 x $\frac{5}{8}$ " sheet metal screws. (FIG. 4) Make sure the screws are secure. Be careful not to over tighten screws, as this could cause the hole to be stripped out.

Step 3

Lay the spring(s) flat on the floor. Measure the length of each spring as shown in Figure 5, and record each length in the space provided. You will need to refer to this length in Step 7.

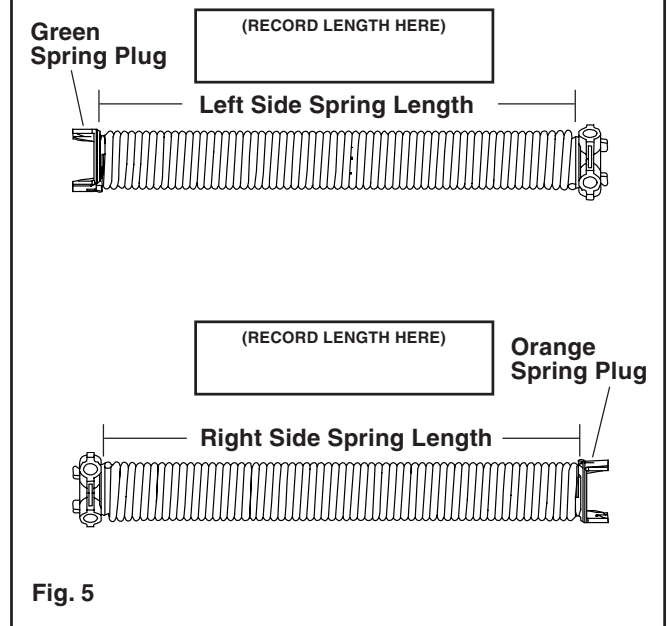
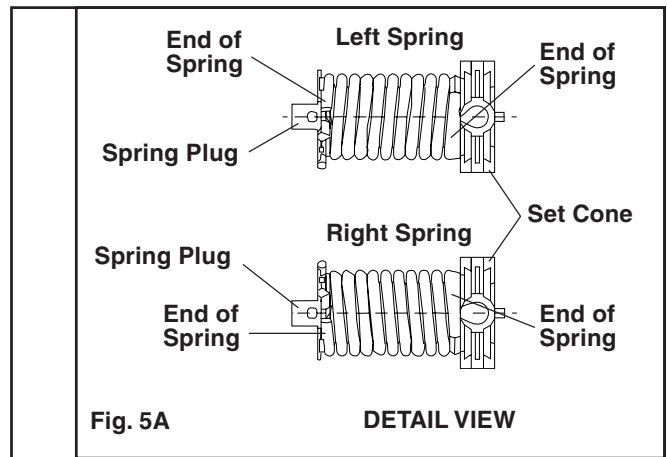
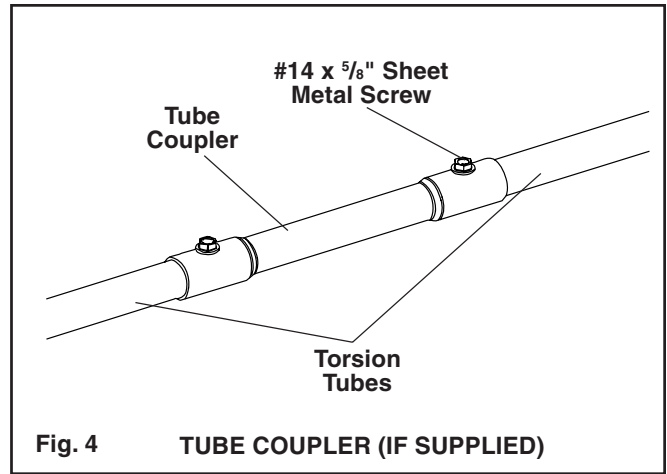

Slide the spring(s), drums, winding unit(s), and end bearing support (if supplied) onto the torsion tube as shown in Figures 6 and 7. Alignment may be required before the tube will pass through spring spacer inside the spring.

If you have one spring see Figure 6 for the configuration of the components on the torsion tube. All “green” components MUST be put on the left side of the tube. Make sure the end bearing support is oriented so that the bearing is facing toward the right drum.

If you have two springs see Figure 7 for the configuration of the components on the torsion tube. All “green” components MUST be put on the left side of the tube and all “orange” components MUST be put on the right side of the tube. The torsion tube coupler will be located between the two springs if so equipped.

The drums should be oriented so that the slots are facing away from the winding unit(s) and the end bearing support (if supplied) as shown in Figure 8, Views A and B. The drums are designated as left side and right side by the letters “L” and “R” respectively found near the cable slot.

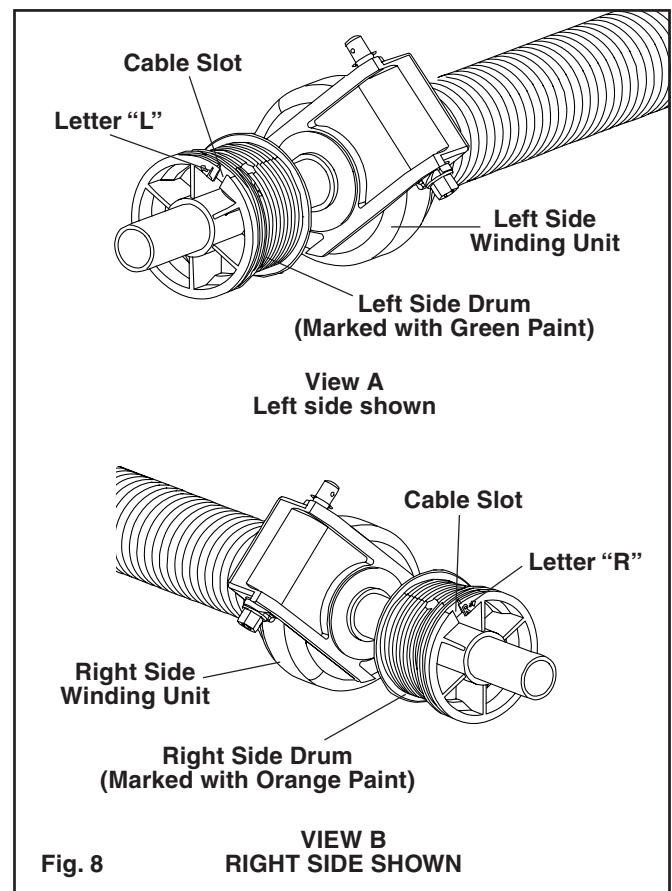
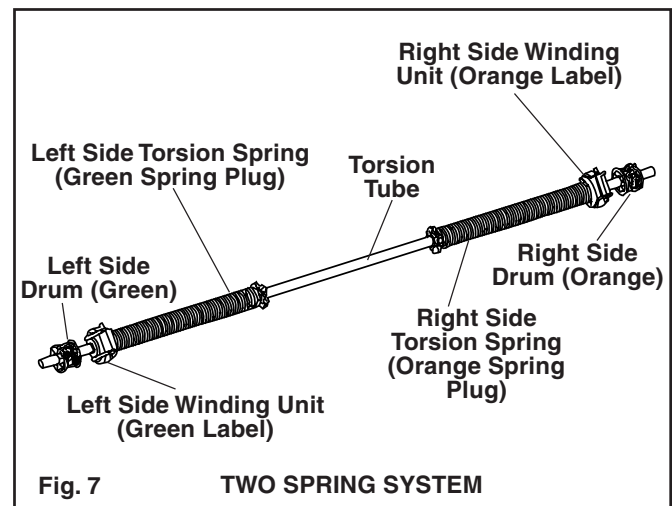
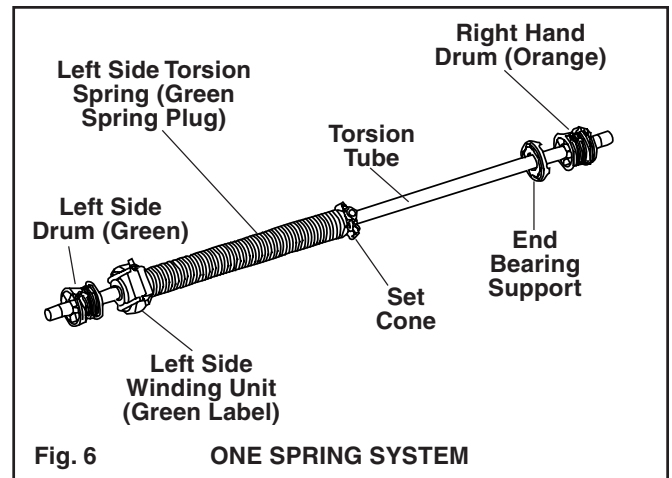

NOTE: IF YOU NEED TO DISCONNECT THE SPRING PLUG FROM THE WINDING UNIT TAKE EXTRA CARE. To remove the spring from the winding unit, two small flat-headed screwdrivers will be required. Two tabs must be released, but only one tab is accessible at a time. Depress the accessible tab with a small screwdriver. To prevent the tab from re-locking, place a second screwdriver between the spring plug and winding unit near the released tab. Wind the winding unit until the other tab can be accessed. Depress the second tab with a small screwdriver. Make sure both tabs have been released. Gently pull the spring from the winding unit.

After all of the components are on the tube, the spring plug should be inserted into the winding unit. Ensure that the spring plug and the winding unit have the same color code before snapping them together. Line up both ears on the spring plug with the two slots in the winding unit and push them together. (Figure 9, Views B, C and D) Slide the components toward the center of the tube to expose 12" of each end of the tube.



WARNING

Make sure that both ears of the spring plug are fully intact and engaged into the winding unit slots. Be certain that both of the tabs in the winding unit slot engage with the spring plug and that the connection between the spring plug and the winding unit is secure before proceeding.

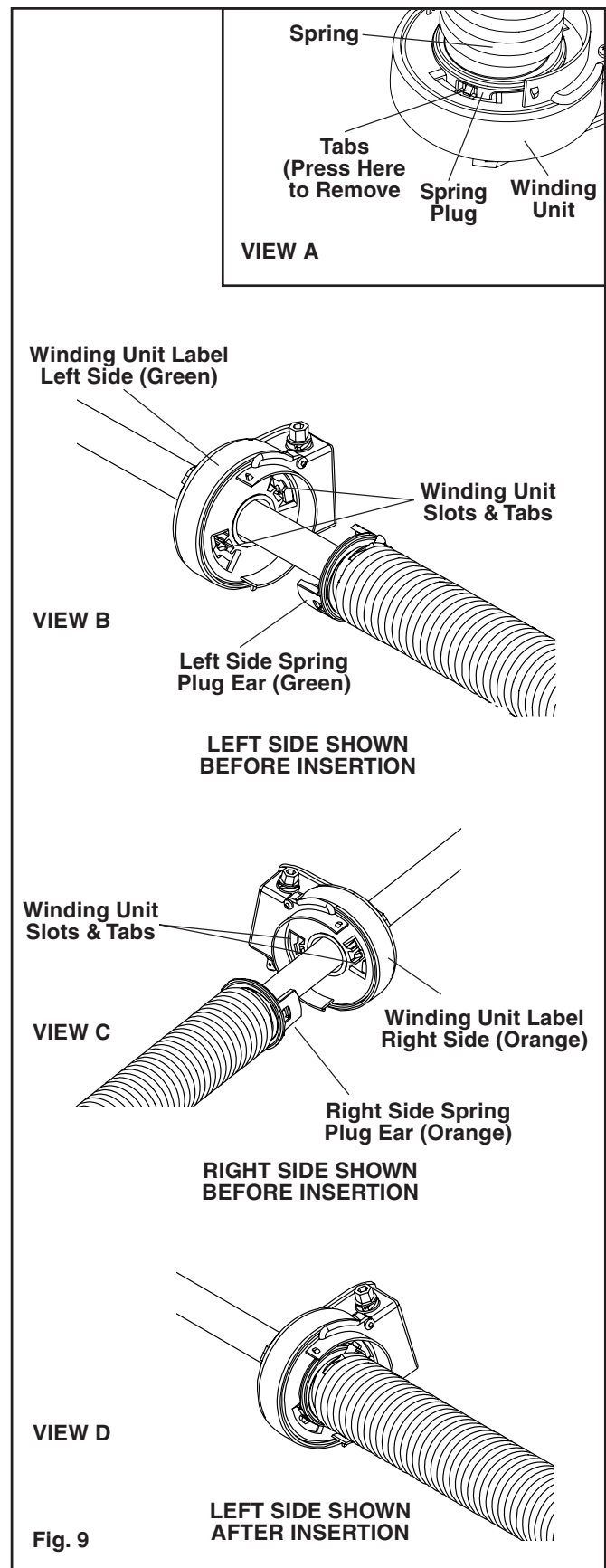

Step 4

Carefully lift up the torsion tube and components and place the ends of the tube in the cradle of each bracket. Pull the tube away from the bracket to slide the drum in between the bracket legs, and engage the winding unit rails in the bracket slot. (FIG. 10, VIEW A) Push the winding unit rails into the bracket until the unit bottoms out.

If you have a door with two springs, go to the right side and repeat the procedure for installing the winding unit in the bracket.

If you have a door with only one spring, go to the right side and install the end bearing support. The end bearing support is installed in the same manner as the winding unit. Pull the tube back just far enough to place the drum between the legs of the bracket. Do not pull the tube further than needed to move the end bearing support and drum into place, as damage may occur to a unit that is engaged on the other side. Line up the end bearing support rails (making sure that the orientation feature is facing away from the bracket) and push it into the bracket until it bottoms out. (FIG. 10, VIEW B)

Center the tube as equally as possible between the brackets, so that an equal amount of the tube is extending from each side.

Step 5 (Doors over 10' wide only)

NOTE: Before installing $\frac{1}{4}$ " lag screws, it is important to drill $\frac{1}{8}$ " pilot holes where the lag screws are to be attached.

Snap the center support onto the center of the torsion tube (or coupler if present). Fasten the support with two $\frac{1}{4}$ " x 1" lag screws to the header above the center of the door. The lag screws should be located at opposite corners of the center support as shown in Figure 11. **Position and shim the mounting location as required to make the tube straight.** Check the distance from the top of the door and the wall or header to the tube along the length of the door to make sure the tube is straight and level.

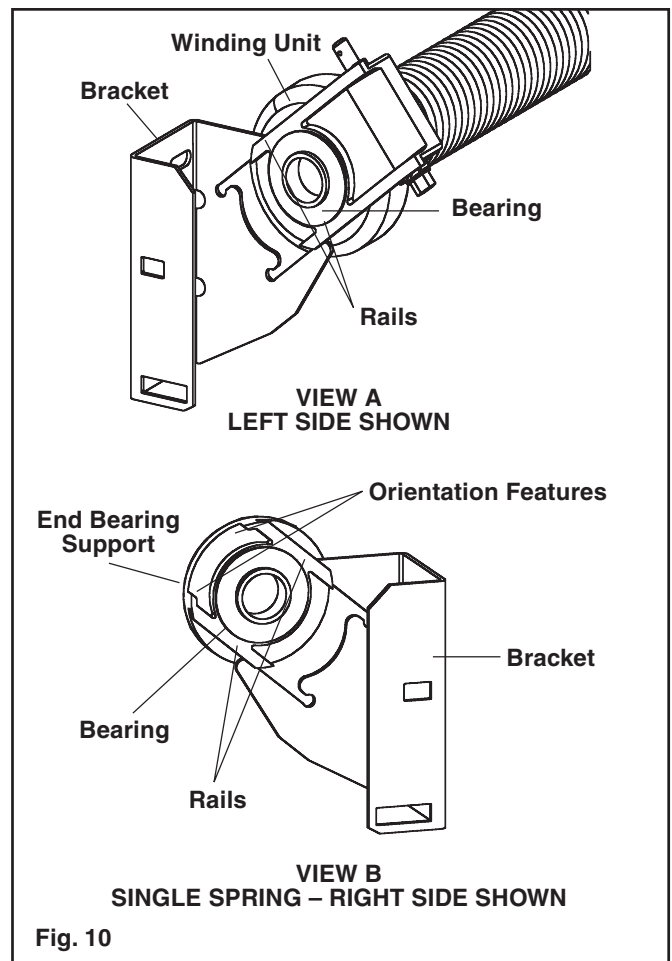

NOTE: The drums and torsion tube are removed from Figure 10, View A and Figure 10, View B for clarity.

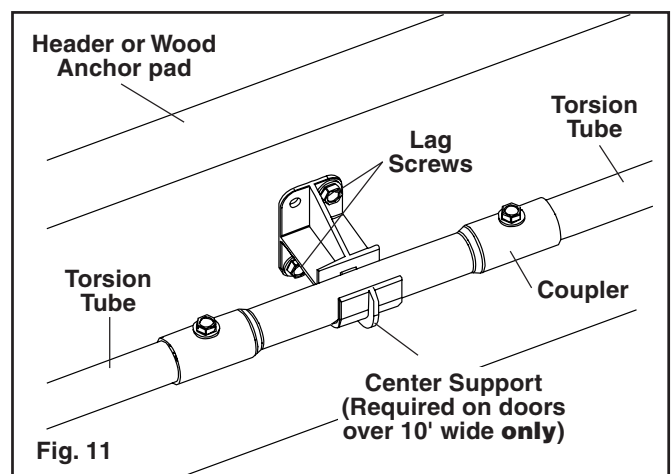

Step 6

Install the included $\frac{1}{4}$ " insert bit (or a $\frac{7}{16}$ " socket) in a medium duty drill: 1000-2500 RPM, (2-4 AMP) variable-speed and reversible. Set the drill to FORWARD (clockwise as you point the drill away from you). Keep this drill and a $\frac{3}{16}$ " hex key handy for Steps 8 and 9.

If the stripe on each spring is not facing toward you as shown in Figure 12, engage the drill with the $\frac{1}{4}$ " insert bit (or $\frac{7}{16}$ " socket) into drive shaft of the winding unit to rotate the spring until the stripe is facing you. (FIG. 12)

NOTE: The $\frac{1}{4}$ " insert bit shown in Figure 12 is secured in a drill chuck, but the drill is not shown.

Step 7

Holding the tube in place, compress the left side spring completely against the winding unit, and then release the spring. Measure and adjust the length of the spring and match the length you recorded in Figure 5.



WARNING

DO NOT STRETCH SPRING(S) BEFORE TIGHTENING SET SCREWS. Stretching the springs could cause the loss of spring tension and possibly allow the door to fall. The length of the spring on the shaft should NOT exceed the relaxed spring length recorded in Step 3 on page 4 of the EZ-Set Torsion Spring System™ Instructions.

NOTE: Be sure to hold the tube in position after you have tightened the spring set screws. Any sliding of the tube from this point on will affect the length of the springs.

Tighten both set screws in the set cone to the torsion tube. Use a $\frac{3}{8}$ " wrench if the springs are supplied with square head set screws as shown in Figure 13, View A. Use a $\frac{3}{16}$ " hex wrench if supplied with internal set screws as shown in Figure 13, View B. **CAUTION:** When resistance is encountered while tightening the set screw, the screw has made contact with the tube. Set screws should be turned from $\frac{3}{4}$ to one full turn after they have made contact with the tube. Additional turns may damage the tube.

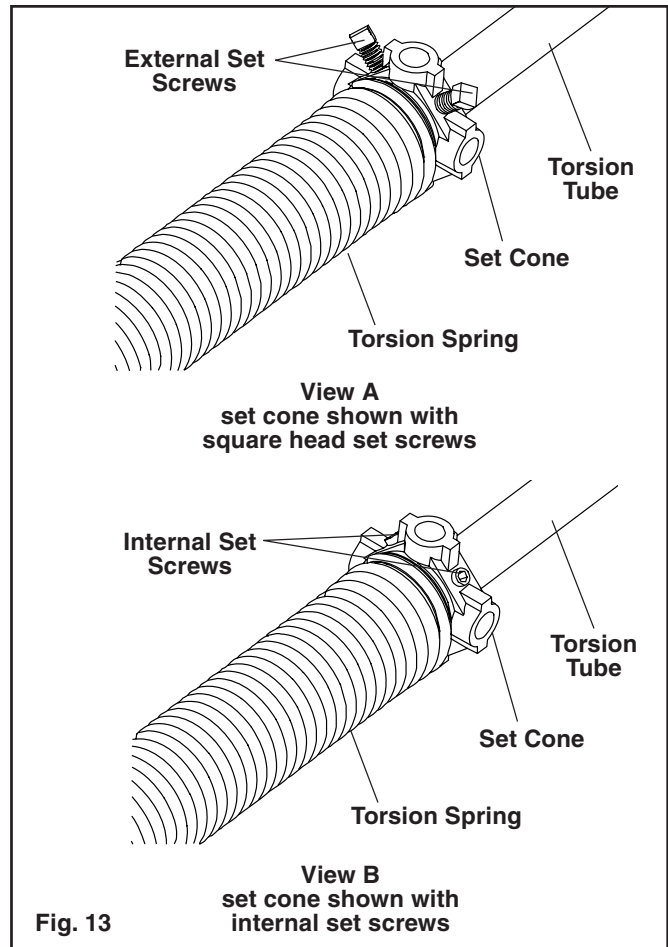
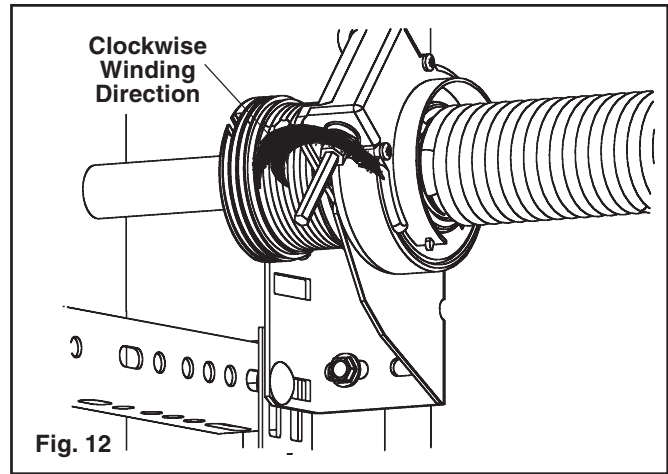

If you have a door with two springs, repeat the above procedure for the right side spring.

NOTE: If you will be installing the optional spring cover, you will need to have torsion springs equipped with internal set screws. See Step 10 for more information.

Step 8

NOTE: Be careful not to shift the tube left or right during this step as this will disturb the gap set in the spring(s).

Starting with the left side, pull the lift cable up from the safety bottom bracket behind the rollers and inside of the jamb brackets. Bring it between the legs of the bracket and behind the drum and insert the cable lug into the drum slot. (FIG. 14, VIEWS A & B) Make sure that both set screws are flush or below the surface of the cable grooves **BEFORE** securing the drum. Take up the cable slack by turning the drum by hand. Make sure the cable is pulled tightly into the drum grooves and the drum is against the bearing in the winding unit, then tighten the most accessible set screw in the drum (only one of two need to be tightened) using a $\frac{3}{16}$ " hex wrench. **CAUTION:** When resistance is encountered while tightening the set screw, the screw has made contact with the tube. Set screws should be turned from $\frac{3}{4}$ to one full turn after they have made contact with the tube. Additional turns may damage the tube. While maintaining cable tension, use the drill (turning clockwise as in Figure 12) to wind the spring 1 or 2 turns. The spring tension will maintain the proper cable tension when you let go.

Go to the right side to secure the right side drum. Pull the cable up between the legs of the bracket, insert the cable lug in the drum slot, and take up the cable slack by turning the drum. Before securing the right side drum, pull the tube toward the right side to make sure there is no gap between the left drum and left bearing. Slide the right drum against the right bearing and secure the drum. There should be $\frac{1}{16}$ " maximum gap between the drums and the bearings on each side. Tighten the most accessible set screw down to secure the right drum using a $\frac{3}{16}$ " hex wrench. **CAUTION:** When resistance is encountered while tightening the set screw, the screw has made contact with the tube. Set screws should be turned from $\frac{3}{4}$ to one full turn after they have made contact with the tube. Additional turns may damage the tube.

NOTE: Verify that the drum marked with the letter "L" is on the left side (FIG. 14, VIEW A) and the drum marked with the letter "R" is on the right side. (FIG. 14, VIEW B)

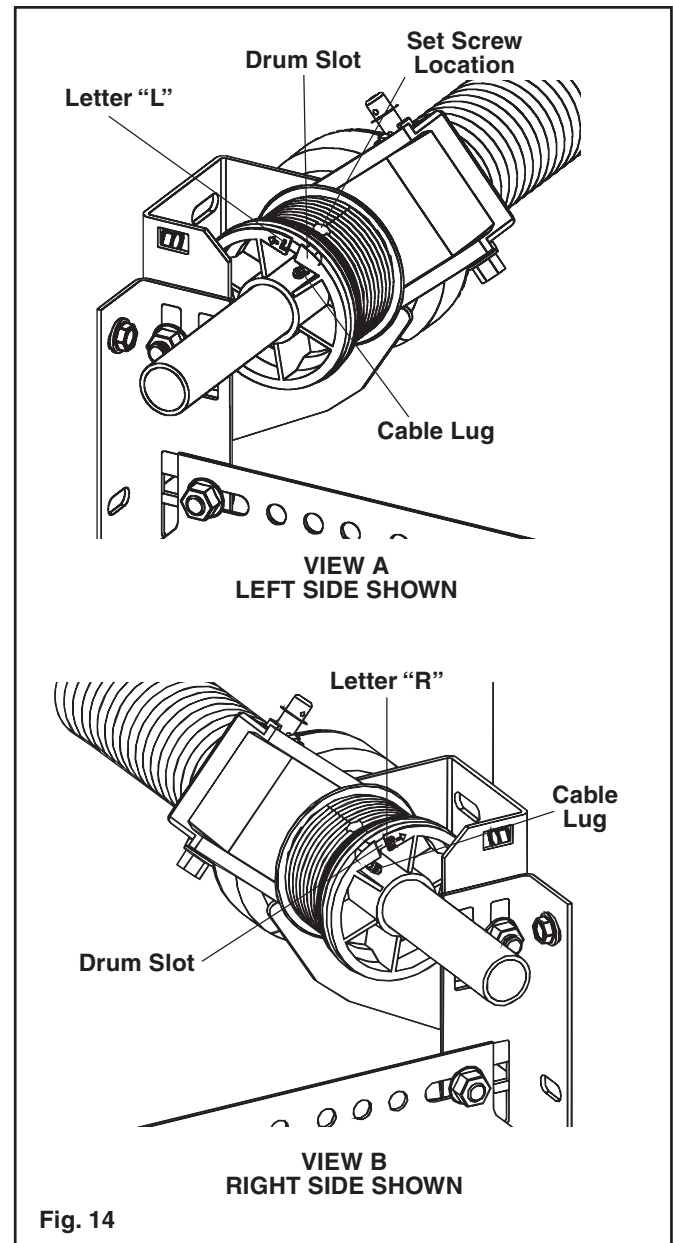

Step 9:

Install the tube retainer as shown in Figure 15. Attach the tube retainer to the EZ-Set Torsion Spring System™ bracket with a $\frac{3}{8}$ " - 16 x $\frac{3}{4}$ " carriage bolt. Be sure to position the carriage bolt and flange nut as shown in Figure 15. **Be sure to install a tube retainer on both the left and right sides of the door.**



WARNING

To avoid personal injury, do not rest hand or any other part of your body on the spring or any part of the EZ-Set Torsion Spring System™ while tensioning or untensioning the spring.

During winding, operate the drill at HALF SPEED until the required number of winds is reached. If additional winding is required or the system has to be completely unwound, wait AT LEAST FIVE MINUTES between consecutive winds/unwinds. If for any reason the unit begins to resist winding STOP winding at once and wait AT LEAST FIVE MINUTES before continuing. Failure to follow these instructions may result in damage to the unit, the rapid release of spring energy, or personal injury.

To remove ALL tension from the spring, unwind (drill in reverse/counterclockwise) until the spring paint stripe is a single straight line and the lift cables are slack.

Only adjust the number of spring winds when the door is completely closed.

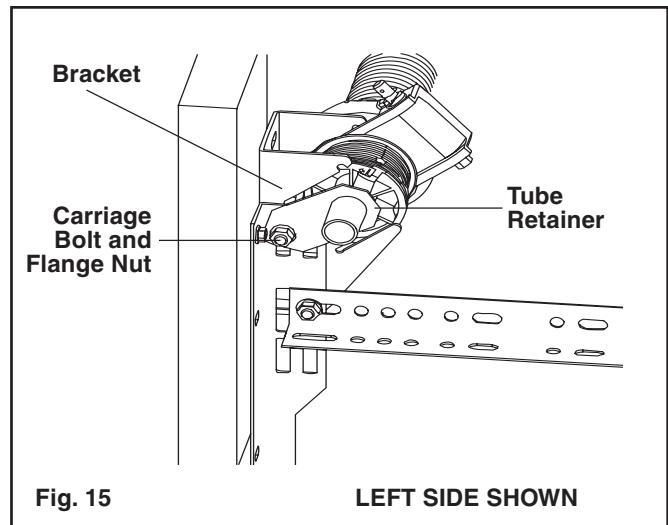

Step 10:

Engage the drill with the 1/4" insert bit (or 7/16" socket) into the drive shaft of the winding unit to wind the spring. See Table C for the total number of winds required for your spring(s).

If you have a door with one spring:

After securing the left and right drums, finish winding the left spring to the specified number of winds.

If you have a door with two springs:

After securing the left and right drums, there will be one or two winds on the left spring. Proceed with winding the right side to the specified number of winds. Go to the left side and finish winding the spring to the specified number of winds.

The number of spaces between stripes on the spring equals the number of winds on the spring. (FIG. 16)

IMPORTANT: Lift the door 3"-4" off of the ground. Starting on the right hand side, tighten the set screw that was not previously tightened in Step 8. Repeat this procedure for the left hand side.

The exact number of winds may be adjusted by adding up to 2 1/4 winds or subtracting 1/2 wind as compared to Table B. Lift the door by hand with the automatic door opener disconnected (if so equipped). If the door lifts by itself or lifts too easily, reduce the number of winds (drill in reverse/counterclockwise). If the door is too hard to lift, increase (drill in forward/clockwise) the number of winds.

IMPORTANT: Prior to opening your door for the first time or attaching an automatic door opener, ensure that the door will clear the brackets and winding unit(s). Failure to check this could result in damage to your door and opener! If the tracks are not correctly aligned or the back hangers are not strong enough, the door may fall. Proceed slowly and carefully. Refer to the standard installation manual before operating the door. Make sure all applicable steps were performed from the standard installation manual. For maintenance of door and springing system, see the standard installation manual.

Your EZ-Set Torsion Spring System™ installation is now complete. If you have the optional spring cover, refer to Step 11.

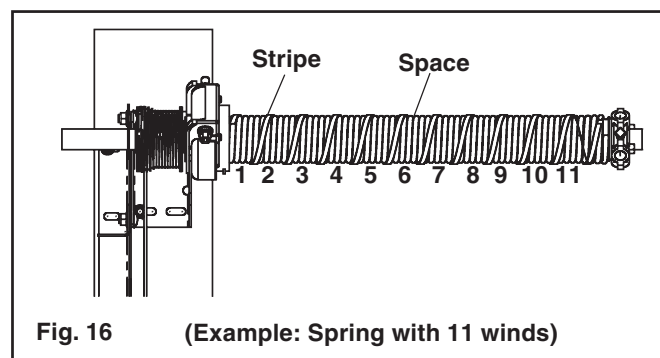

SPRING WINDING — TABLE C

DOOR HEIGHT	SPRING WINDS	<p>Note: 1/8 turn = 45°</p> <p>NOTE: If you have a door with two springs, each spring requires the number of winds specified in the table.</p>
5'9"	9 ³ / ₈	
6'0"	9 ³ / ₄	
6'3"	10 ¹ / ₈	
6'6"	10 ¹ / ₂	
6'9"	10 ⁷ / ₈	
7'0"	11 ¹ / ₄	
7'3"	11 ⁵ / ₈	
7'6"	12	
7'9"	12 ³ / ₈	
8'0"	12 ³ / ₄	

Step 11 Optional Cover Installation

Snap the cover support over the torsion tube next to the set cone with the open ribbed end facing toward the set cone. (FIG. 17) If not already done, snap one edge of the two halves of the cover together. (FIG. 18, VIEWS A & B) Spread the two halves of the cover to go over the spring. Engage the projections on the winding unit and the cover support with the cover tube. Snap the open edge of the cover closed by pinching the locking feature between your fingers and running them down the length of the cover. (FIG. 19) If your door has two springs, repeat the same procedure for the right side.

IMPORTANT: In order to install the spring cover, the set cone must be equipped with internal set screws as shown in Figure 13, View B. If your spring has square head set screws, you must remove all spring tension and replace them with internal set screws. If you did not receive screws with your spring cover, please call the consumer hotline.

