

**MODEL #:**

3213: RAISED PANEL

3211: FLUSH PANEL

**VINYL TOP SEAL:**

- YES (OPTION)
- NO

**EXPANDED POLY-STYRENE INSULATION:**  
R=9.1

**SKIN MATERIAL:**

24 GA. PRE-PAINTED EXTERIOR

- RAISED PANEL (3213)
- FLUSH PANEL (3211)

27 GA. PRE-PAINTED WHITE INTERIOR  
INTERIOR STUCCO EMOSS

**SILICONE THERMAL BREAK:**

**REINFORCING STRUTS:**

- NONE
- 2 1/4" STRUT
- 3" STRUT

**AIRCRAFT CABLE:**  
7:1 SAFETY FACTOR

**BOTTOM ASTRAGAL:**

- 3 1/2" (STANDARD)
- 7" (OPTIONAL)

2 1/8"

**SECTION TYPE:**  
TONGUE & GROOVE

**STEEL BALL BEARING ROLLER:**

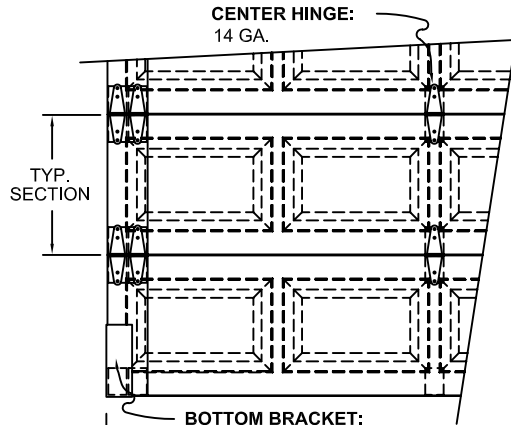
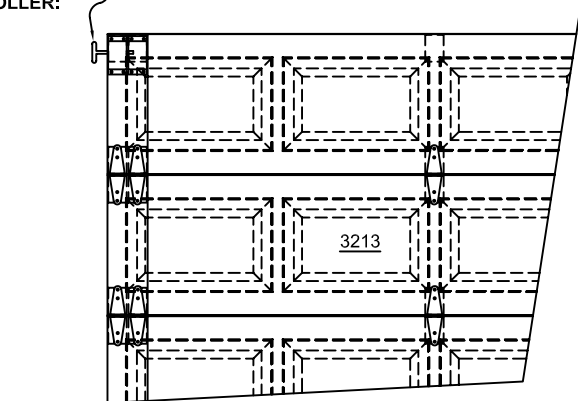

19 1/2" x 12" WINDOW LITE  
SEE TABLE #3

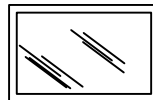

WINDOW FRAME CONSIST OF AN EXTERIOR FRAME AND AN INTERIOR RETAINER, MADE OF CELLULAR PVC EXTRUSIONS.

**GLAZING OPTIONS:**

- SOLID - NO GLAZING
- 1/8" DSB
- 1/2" INSULATED
- 1/8" PLEXIGLASS

**40 1/2" X 12" LITE**

ONLY FOR 8', 9', 12', 12' 2", 16', 16'2", 18', 18'2"

**BACKUP PLATES:**  
19 GA. PRIMED

**TOP BRACKET:**  
12 GA.

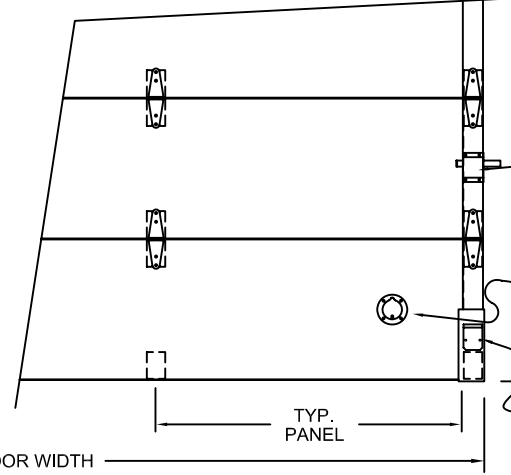
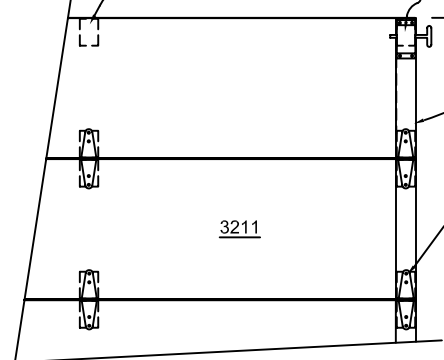

**END STILES: (PRE-PAINTED)**

- 18 GA. SINGLE END STILES (THRU 14'-2" WIDE)
- 16 GA. DOUBLE END STILES (OVER 14'-2" WIDE)

**ROLLER HINGE:**  
14 GA. MIN.

**EXTERIOR COLOR:**

- WHITE
- BROWN
- ALMOND
- SANDTONE
- DESERT TAN
- TRINAR BEIGE
- TRINAR WHITE

**LOCK:**

- #2 END STILE
- #3 CYLINDER LOCK - LOCATED IN FIRST CENTER STILE FROM THE RIGHT (INSIDE LOOKING OUT)
- NONE

**EXHAUST PORT:** (CENTERED ON LOCATION OF RAISED PANEL)

- LEFT  3"
- RIGHT
- CENTER
- NONE



CUST:  
JOB:  
ARCH:  
CONT:

MODEL #:  
DOOR WIDTH:  
DOOR HEIGHT:

QTY:

# OF SECTIONS HIGH  
(SEE TABLE #1)

# OF PANELS WIDE  
(SEE TABLE #2)

SECTIONS TO GLAZE:

PANELS TO GLAZE:

**SHEET 'M-7'**

DATE: \_\_\_\_\_

BID #: \_\_\_\_\_

PAGE \_\_\_\_\_ of \_\_\_\_\_

# MODEL #'s 3213, 3211

**TABLE #1  
SECTION CHART**

DOOR HEIGHT	NUMBER OF SECTIONS
6'0" - 7'0"	4
7'6" - 8'9"	5
9'0" - 10'6"	6
10'9" - 12'3"	7
12'6" - 14'0"	8
14'3" - 15'9"	9
16'0" - 17'6"	10
17'9" - 18'-0"	11

NOTE: DOOR HEIGHTS AVAILABLE IN 3" INCREMENTS (NOT AVAILABLE IN 7'3" HEIGHT)

**TABLE #2  
PANEL CHART**

DOOR WIDTH	NUMBER OF PANELS
6'2" - 7'10"	3
8'0" - 9'10"	4
10'0" - 11'10"	5
12'0" - 13'10"	6
14'0" - 15'10"	7
16'0" - 18'10"	8
19'0" - 19'10"	9
20'0" - 23'10"	10

**TABLE #3  
LITE AVAILABILITY CHART**

DOOR WIDTH	MAXIMUM LITES PER SECTION
6'0" - 9'10"	4
10'0" - 11'10"	5
12'0" - 13'10"	6
14'0" - 14'2"	7
*14'4" - 15'10"	5
*16'0" - 18'10"	6
*19'0" - 19'10"	7
20'0" - 20'-2"	8

\* 14'4" WIDE & OVER GETS DOUBLE END STILE. END PANELS WILL NOT BE GLAZED.

MAX. WINDOW SECTIONS PER DOOR

1/8" DSB:  
NO LIMIT EXCEPT BOTTOM SECTION

1/2" INSULATED:  
THRU 10'2" WIDE - 3 SECTIONS  
OVER 10'2" WIDE - 1 SECTION

**TABLE #4  
REINFORCEMENT CHART**

DOOR WIDTH	DOOR HEIGHT		
	UP TO 10'0"	10'3"-14'0"	14'3"-18'0"
UP to 14'2"	NONE	NONE	NONE
14'4" to 18'2"	(3) 2-1/4" Struts per Door	(4) 2-1/4" Struts per Door	(5) 2-1/4" Struts per Door
18'4" to 20'2"	(3) 3" Struts per Door	(4) 3" Struts per Door	(5) 3" Struts per Door
20'4" to 24'2"	(1) 4" C-CHANNEL per sec	(1) 4" C-CHANNEL per sec	(1) 4" C-CHANNEL per sec