

# INSTALLATION INSTRUCTIONS

## Attaching an Automatic Opener

(For use with Steel Residential Garage Doors)

### Things to Know Before You Begin

Read the instructions completely before starting the installation of the automatic opener. Becoming familiar with the components before attaching the automatic opener to the door will reduce the installation time.



**WARNING**

In the interest of safety this symbol means **WARNING** or **CAUTION**. Personal injury and/or property damage may occur unless instructions are followed carefully.

**Clopay**<sup>®</sup> BUILDING PRODUCTS  
*A Griffon Company*

**Consumer Hotline**  
**1-800-225-6729**



**WARNING**

To avoid risk of strangulation or personal injury to children, you must remove the pull down rope when you install an automatic garage door opener.

**IMPORTANT:** When installing an automatic garage door operator, make sure to follow the manufacturer's installation and safety instructions carefully. **Remove the pull down rope and unlock or remove the lock.** If attaching an operator bracket to the wooden anchor pad, make sure the wood anchor pad is free of cracks and splits and is firmly attached to the wall. Always drill pilot holes before attaching lag screws.

To avoid damage to your door, you must reinforce the top section of the door in order to provide a mounting point for the opener to be attached. **Failure to reinforce the door as illustrated will void your Clopay Warranty.**

### Step 1

#### Determining Operator Reinforcement Bracket Size

Measure the height of the top section. It will measure either 18", 19<sup>3</sup>/<sub>8</sub>", or 21". For 18" and 19<sup>3</sup>/<sub>8</sub>" door sections, the operator reinforcement bracket must be cut using a hacksaw as shown in Figure 1.

Be sure to wear a sturdy pair of gloves while cutting the bracket and watch for sharp edges. It may be necessary to file the edge of the bracket that was just cut.

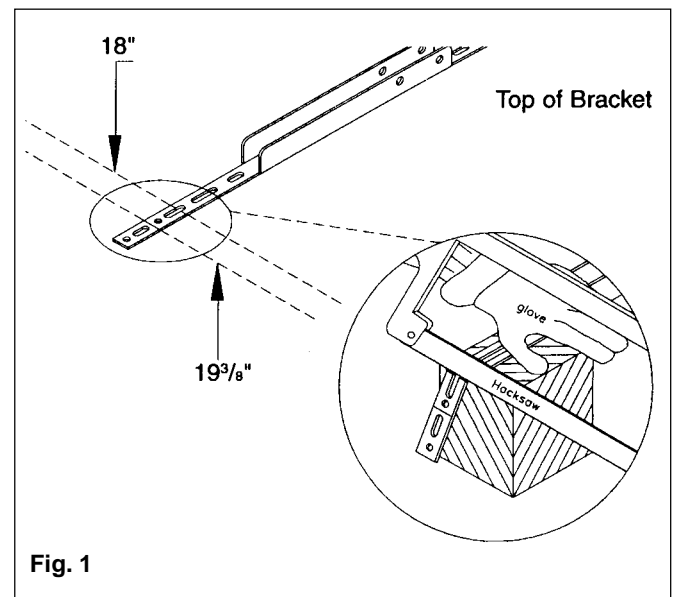

Fig. 1

## Step 2

### Attachment of Operator Reinforcement Bracket to Door

Figures 2 through 7 show the installation of the Operator Reinforcement Bracket. Each illustration corresponds to specific door width. If the drawing indicates a part attached to a hinge, then the hinge screws need to be removed, the part installed, and the screws replaced.

All arrows indicate the use of a 1/4" x 1/2" bolt, 1/4" lock washer and 1/4" nut. If the arrow has a star (\*) next to it, use a 1/4" x 3/4" sheet metal screw on **Models 1000, 1001, 1100, 183, 186, and 187 only.**

**NOTE:** Horizontal angles and struts are shown cut away for illustration purposes only. **DO NOT** notch these pieces. (FIG. 2-5)

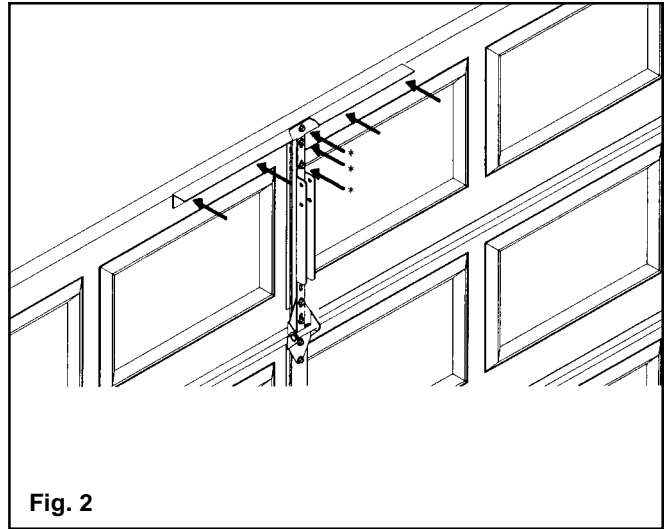

### 8' Up to 9'10" Wide Doors Solid (without windows) or with windows

- (1) 28" long horizontal angle required,
- (1) operator reinforcement bracket.

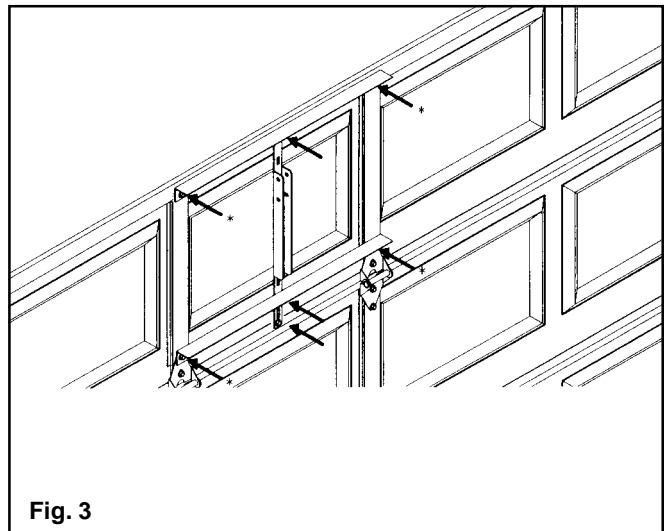

### 10' Up to 14'10" Wide Doors 10' - 11'10" & 14' - 14'10" Wide Doors Solid (without windows)

- (2) 28" long horizontal angles required,
- (1) operator reinforcement bracket required.

### 12' - 13'10" Wide Doors Solid (without windows) or with windows

- (2) 56 1/2" long horizontal angles required,
- (1) operator reinforcement bracket required.

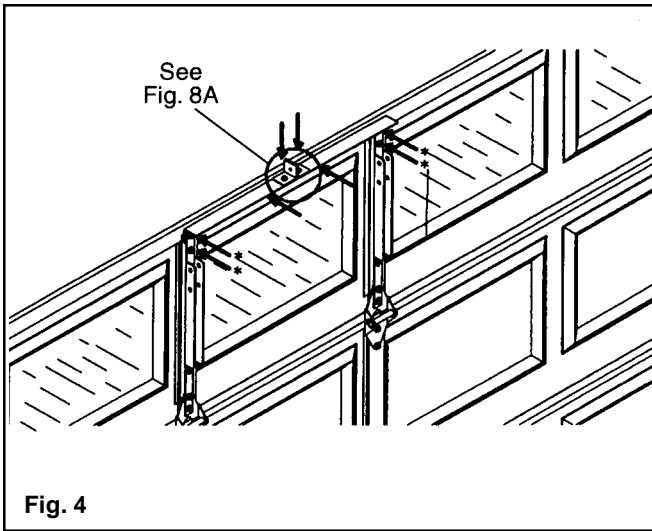

Fig. 4

**10' - 11'10" & 14' - 14'10" Wide Doors  
Windows in Top Section**

- (1) 28" long horizontal angle required,
- (2) operator reinforcement brackets required.

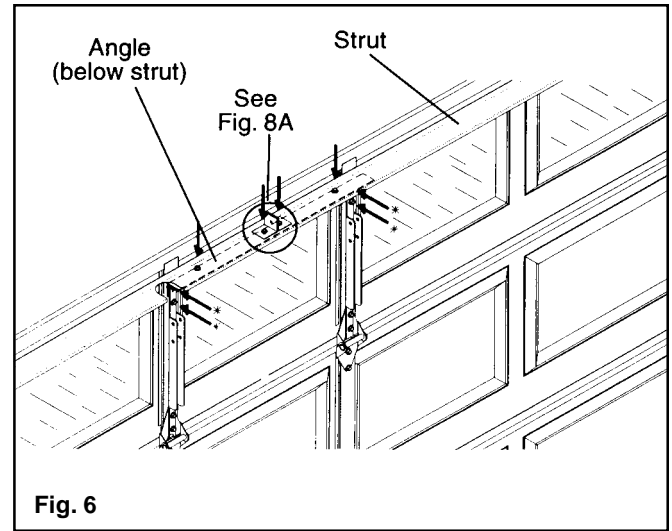

Fig. 6

**15'0" to 15'10" Wide Doors  
Strut Supplied  
Windows in Top Section**

- (1) 28" long horizontal angle required,
- (2) operator reinforcement brackets required.

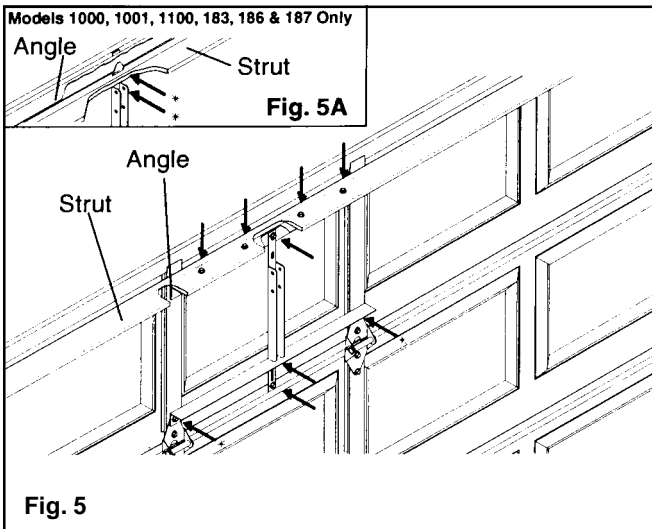

Fig. 5

**15'0" to 15'10" Wide Doors  
Strut Supplied  
Solid (without windows)**

- (2) 28" long horizontal angles required,
- (1) operator reinforcement bracket required.

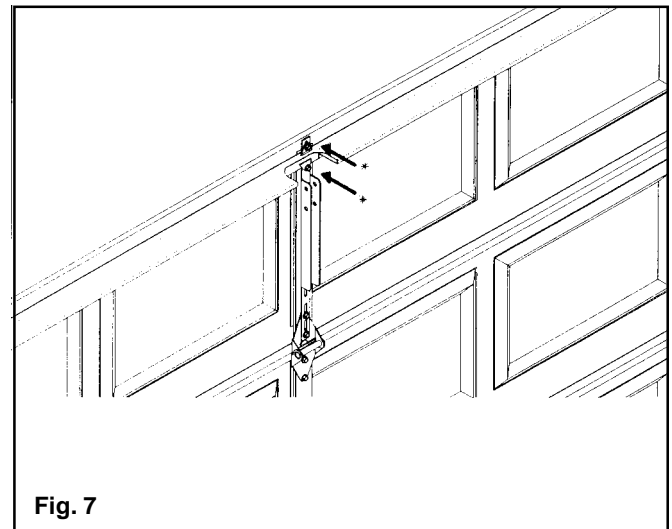

Fig. 7

**16'0" to 18'10" Wide Doors  
Strut Supplied  
Solid (without windows) or  
with windows**

- No horizontal angle required,
- (1) operator reinforcement bracket required.

### Step 3

#### Attachment of Opener Arm

Attach the opener arm of the automatic garage door opener to the Opener Reinforcement Bracket by sliding the clevis pin through either hole A or B, then through the hole on the opener arm and finally through the opposite hole A or B. Once the clevis pin is completely through, insert the cotter ring at the end of the clevis pin. See Figures 8 & 8A.

The opener arm should be attached roughly at the same height as the top rollers of the door. This is about 3" to 5" from the top of the door.

