

# INSTALLATION INSTRUCTIONS

## Double Track Low Headroom Conversion Kit

(For use with Steel Doors only)

- Reduces headroom requirement to 4½" - Extension Spring and EZ-Set Extension Spring System™
- Reduces headroom requirement to 9½" - EZ-Set Torsion Spring System™

### Parts Contained:

#### Quantity

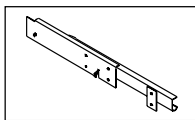

- 2 LHR Front Upper Track (1 pair) Starter Angle and (1) Junction Plate

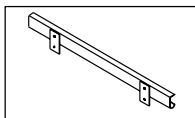

- 2 LHR Rear Upper Track (1 pair) (2) Junction Plates

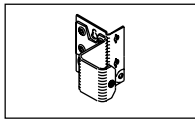

- 2 LHR Safety Bottom Brackets (1 pair)

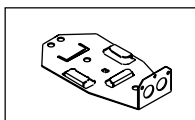

- 2 LHR EZ-Set Extension Spring System™ Housing Brackets (1 pair)

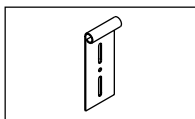

- 2 LHR Top Bracket (1 pair)

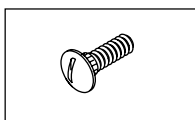

- 14 Track Bolts  
¼" x ⅝"

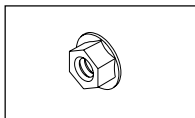

- 14 Flange Nuts  
¼" Diameter

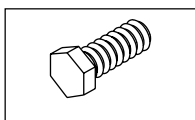

- 4 Hex Head Bolts  
⅜" x 1"

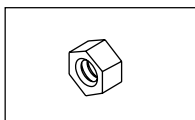

- 4 Hex Nuts  
⅜" Diameter

### Installation Instructions



#### IMPORTANT!

Carefully read the following instructions before beginning installation of the Double Track Low Headroom Conversion Kit. Installation of this kit should be done by a person with reasonable mechanical aptitude.

#### Step 1

The Double Track Low Headroom (LHR) Conversion Kit is designed to modify the minimum headroom clearance required. (See chart below) This kit works with both 12" and 15" radius horizontal track. To determine the radius of the track, measure from the center point of the radius to the bottom of the track as shown by dimension "R". (FIG. 1)

	EZ-Set Extension Spring System™	Extension	EZ-Set Torsion Spring System™
Minimum Headroom	4½"	4½"	9½"

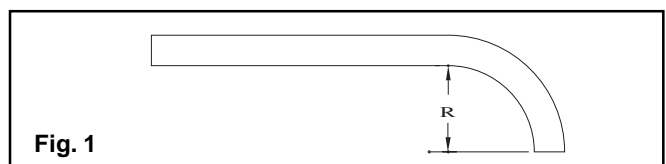

If dimension "R" measures 11" to 12", then the track radius is 12". If "R" measures 14" to 15", then the track radius is 15". Also measure and check the headroom distance, which is the space above the top of the opening. (FIG. 2)

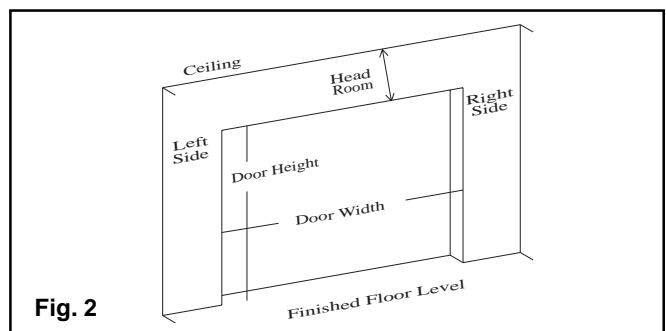

## Step 2

Refer to Table 1 to determine the reduced vertical track length. Measure and remove excess length from the top of the vertical track. (FIG. 3) Two 1/4" diameter holes need to be redrilled at the top of the vertical track. These two holes are used to attach the vertical track to the flag bracket. If there is a clearance problem, it may be necessary to cut 3" off the top of the flag bracket. (FIG. 3)

Table 1

Door Height	Reduced Vertical Track Length	
	12" Radius	15" Radius
6'-6"	65"	61½"
7'-0"	71"	67½"
7'-6"	77"	73½"
8'-0"	83"	79½"

**Note:** For door heights with 4½" of headroom not listed in Table 1, take height of door in inches and subtract 12" for 12" radius, or 15½" for 15" radius to get reduced vertical track length.

**Note:** Actual opening (vehicle) clearance is opening height minus 6" (e.g.: 7' high doors installed with double track low headroom hardware will have an opening clearance of 6'6").

## Step 3a (Extension and EZ-Set Extension Spring System™ Only)



**WARNING**

Heavy duty bottom brackets (not provided) are required for doors over 250 lb. Call the toll free number provided with the main instruction manual if your door weighs over 250 lb.

Bottom brackets are mounted with ears located on bottom. The "L" and "R" letters on the brackets designate left hand and right hand brackets (inside looking out). (FIG. 4) Mount right hand LHR safety bottom bracket to right side of bottom door section by inserting the bottom bracket locking tabs into the end stile key slots. This is done by pushing inward towards the center of the door. To fully engage the bottom bracket in the end stile push inward and up simultaneously. Fasten the bottom bracket to the door using two of the #14 x 5/8" sheet metal screws provided in the standard door hardware. (FIG. 5) Repeat procedure for left side.

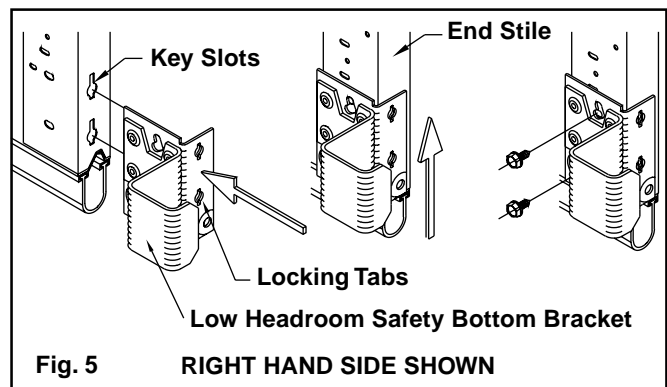
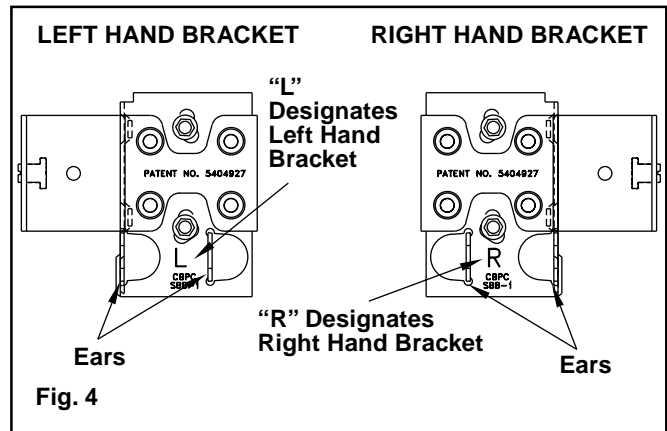
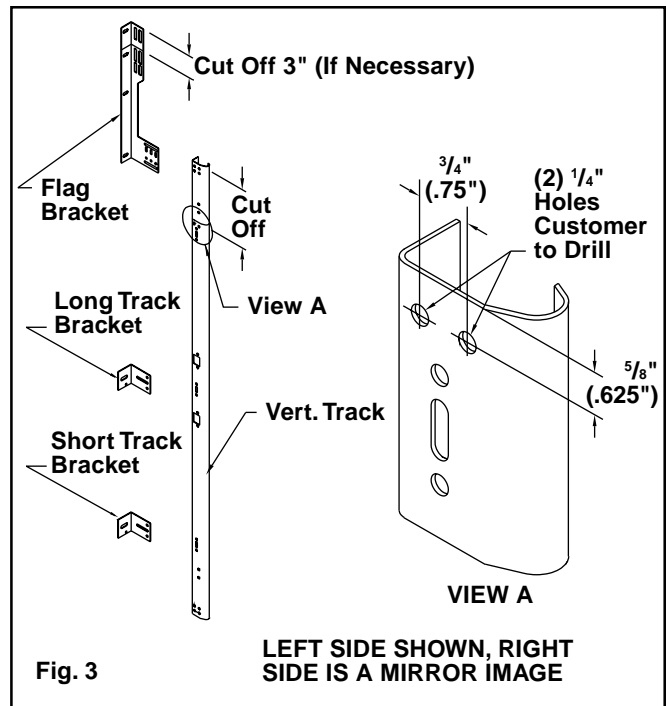

### Step 3b (EZ-Set Torsion Spring System™ Only)

The bottom brackets that came with the door, NOT the bottom brackets in this kit are to be used for this setup. Follow standard installation for bottom brackets. (See Instruction Manual)



### WARNING

Failure to properly engage locking tabs on bottom bracket into key slots on edge of door, can result in severe injury when spring tension is applied.

### Step 3c (EZ-Set Extension Spring System™ and Extension Springs Only)

Hook looped ends of cable over buttons on safety bottom brackets. (FIG. 6)

**Note:** DO NOT attach looped ends of lifting cables to bottom brackets at this time if using the EZ-Set Torsion Spring System.™

### Step 4

Using the instruction manual supplied with the door, complete Steps 4 through 12 of the “Installing the New Door” section. Once completed, proceed to Step 5.

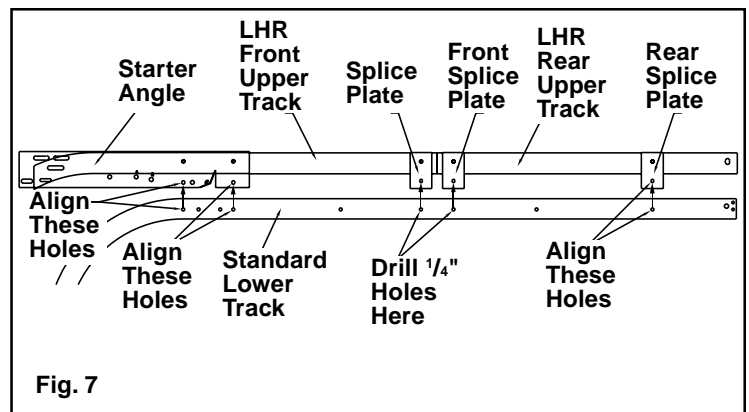
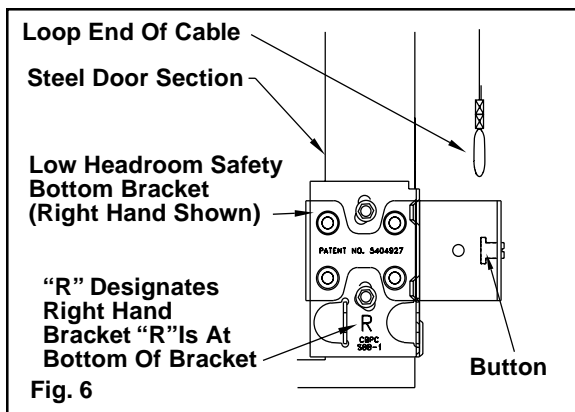

**NOTE:** To correctly position the LHR rear upper track, the back of the LHR rear upper track has a vertical slot on it.

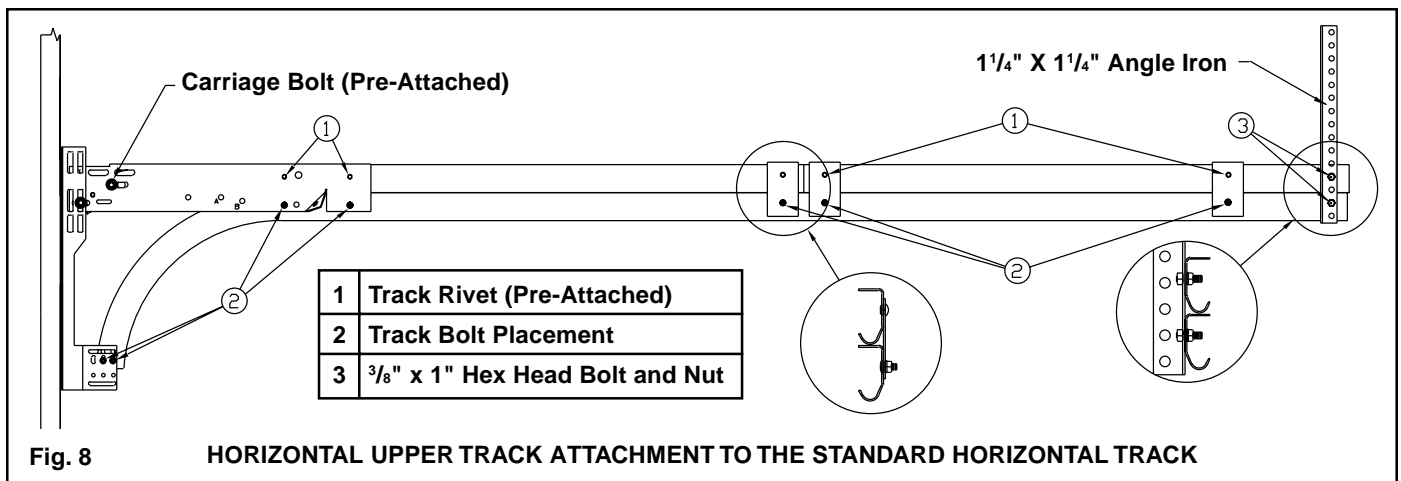

### Step 6

Temporarily support the rear end of the track with a rope from the trusses overhead in the garage or on a tall ladder. (FIG. 9)

### Step 7

Attach the curved end of the lower horizontal track to the flag bracket with two  $\frac{1}{4} \times \frac{5}{8}$ " track bolts and  $\frac{1}{4}$ " flange nuts so that the heads of the screws are on the inside of the track. Attach the starter angle to the flag bracket by aligning them with a  $\frac{3}{8}$ "-16  $\times \frac{3}{4}$ " carriage bolt and  $\frac{3}{8}$ " flange nut included with the door. (FIG. 10) The horizontal and vertical track must join together to form a continuous channel for the rollers. (FIG. 11)

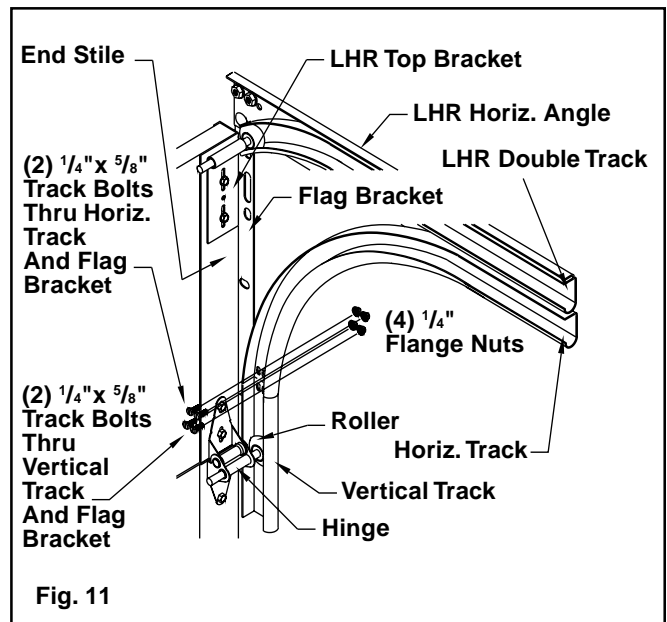
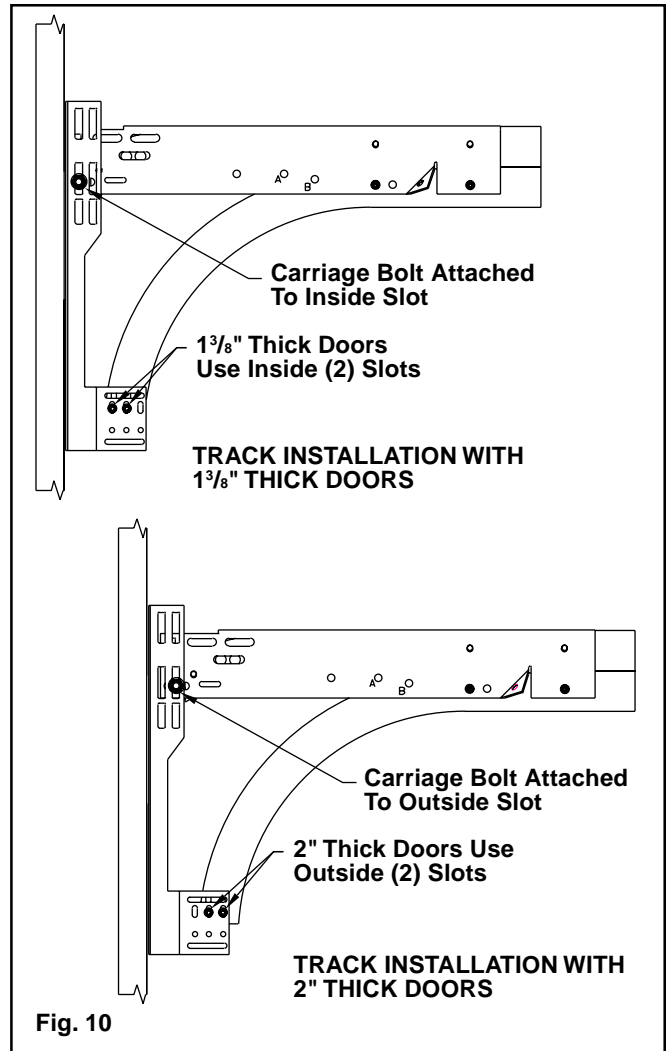
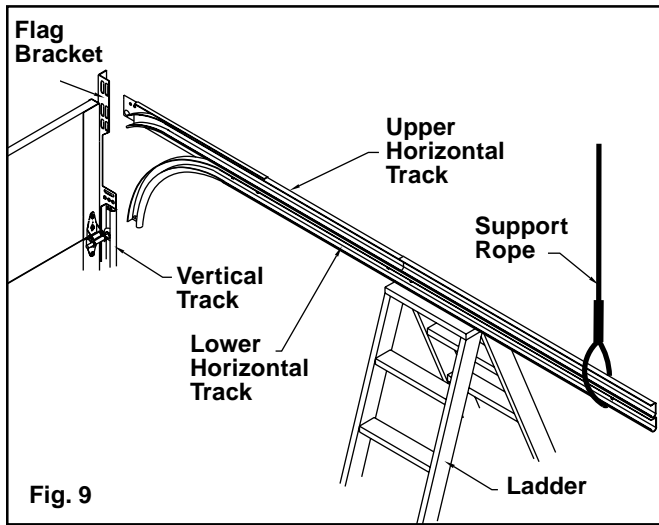

## Step 8

Insert rollers in low headroom top brackets. On each side of door, insert each roller into horizontal track. Slide each low headroom bracket down the top section until top section is tight against steel jamb. If a top strut has been installed on the section, the top roller bracket will go between the strut and the section, with the roller above the strut. Line each low headroom top bracket up with the side of the top section. Using both slots in each low headroom bracket as a guide, drill  $\frac{5}{32}$ " pilot holes in the center of each slot. Attach top bracket to end stile using (2) #14 x  $\frac{5}{8}$ " sheet metal screws for steel doors. (FIG. 12)

**NOTE:** Do not tighten fasteners for top brackets until springs are installed and door is ready to be used. This will allow for final adjustments later, if needed.

## Step 9

Proceed to Step 7 of the "Assembling and Installing the Track" section of the installation manual included with the door. The only exception is that the upper and lower horizontal tracks must each be fastened to the rear track hanger with a  $\frac{3}{8}$ " x 1" hex head bolt and nut. (FIG. 8)

## Attaching the Spring System

This section outlines instructions for three types of springs:

- Standard Extension Spring
- EZ-Set Extension Spring System™
- EZ-Set Torsion Spring System™

## Standard Extension Spring

**NOTE:** Cable will extend to bottom bracket on OUTSIDE of track.

### Step 1

Complete Step 1 of the Extension Spring Installation instructions found in the instruction manual provided with the door.

### Step 2

#### 12" Radius Track

Using a  $\frac{3}{8}$ " x  $1\frac{1}{4}$ " bolt,  $\frac{3}{8}$ " washer, and  $\frac{3}{8}$ " nut, attach the stationary sheave to the OUTSIDE of the starter angle through the hole labeled with an "A" stamped above it.

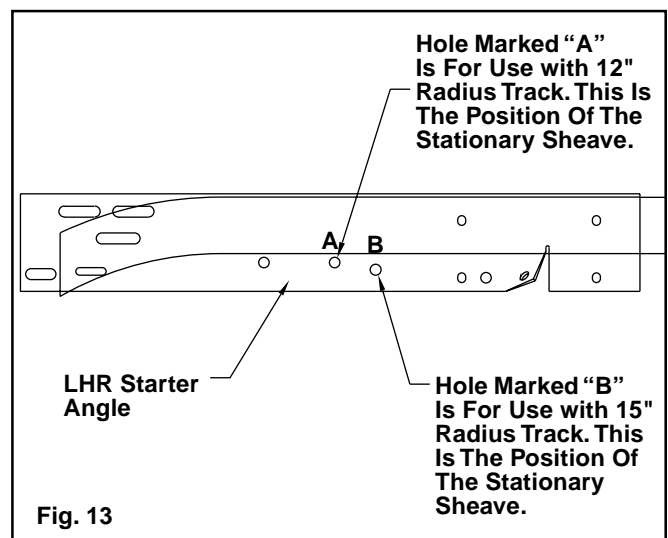
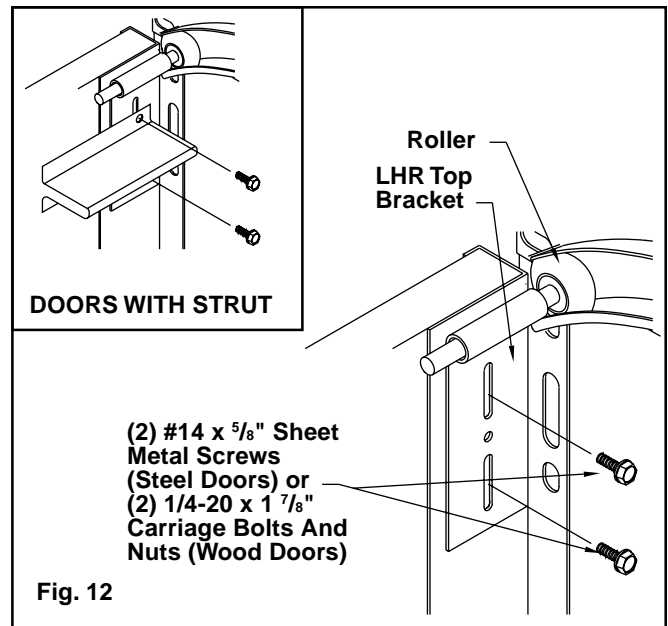

### 15" Radius Track

Attach the stationary sheave to the outside of the starter angle through the hole with a "B" stamped above it. (FIG. 13)

**NOTE:** The head of the bolt must be on the INSIDE of the starter angle.

### Step 3

Complete Steps 3 through 6 of the Extension Spring Installation instructions section in the original instruction manual.

#### Step 4

Tie the cable to the three hole adjusting clip exactly as shown in View B. (FIG. 14) Hook the cable to the bent out flange on the starter angle with a "S" hook. Adjust the knot at the three hole adjusting clip. Adjust so that all spring tension is relieved and the cable holds the springs almost horizontal. The springs should be stretched the same on both sides of the door. (Fig. 14)

**IMPORTANT:** Attach the warning tag found in the white envelope with orange print to the spring assembly (this tag may already be attached). See instruction manual at the end of the extension spring installation section for a placement drawing.

#### Step 5

Proceed to the instruction manual beginning with "Installing Safety Containment Kit" section.

### EZ-Set Extension Spring System™

Complete Step 1 from the EZ-Set Extension Spring System™ instructions to assemble sheaves to extension springs.

Follow the Double Track Low Headroom Instructions for EZ-Set Spring™ section in the EZ-Set Extension Spring System™ Instructions provided with the spring system. The low headroom housing bracket is provided with this kit.

### EZ-Set Torsion Spring System™

Follow standard EZ-Set Torsion Spring System™ instructions that are included in the EZ-Set Torsion Spring System™ box.

The only exception is that Figure 2 in the standard EZ-Set Torsion Spring System™ instructions is not correct for the attachment of the winding unit bracket to the flag bracket. The winding unit bracket is to be attached to the flag bracket as shown with a  $\frac{3}{8}$ " x  $1\frac{1}{4}$ " carriage bolt and nut which are included in the EZ-Set Torsion Spring System™ box. (FIG. 15)

