

Supplemental Instructions

Torsion Spring Installation

This is a supplement to the **Residential Garage Door Instructions** (referred to as the MANUAL). It covers installation of torsion springs (STEP 14 of the MANUAL). For all other information and safety warnings concerning your garage door, see the MANUAL. Read the information in both manuals before beginning installation.

Please read and understand these instructions completely before proceeding with the installation of torsion springs. Carefully follow these instructions to avoid personal injury or property damage.

Use these instructions for torsion springs only. Your spring hardware should match the list shown in Table TOR-1. If you are missing any spring hardware, call the toll-free Consumer Services number found on the front cover of the MANUAL.

Safety Information



WARNING

Torsion springs can be very dangerous if they are improperly installed or mishandled. Do not attempt to install them yourself unless 1) you have the right tools and reasonable mechanical aptitude or experience and 2) you follow these instructions very carefully.

Materials Required for Torsion Spring Installation:

1. Two 9/16" box wrenches
2. 7/16" socket wrench
3. Two 1/2" diameter, 18" long cold rolled solid steel winding bars (NOTE: Winding bars are available at most hardware stores)
4. Locking pliers
5. Wood Anchor Pad

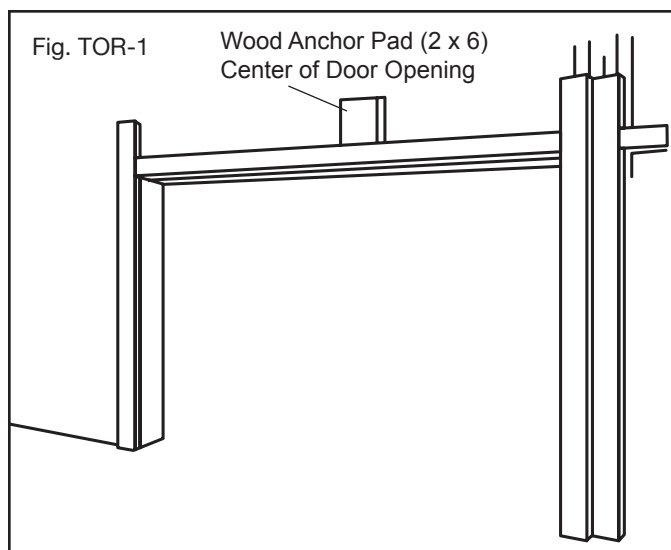

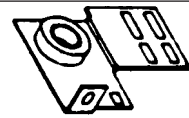
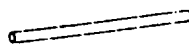
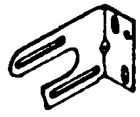

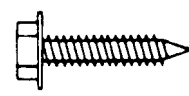
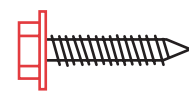
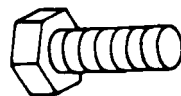

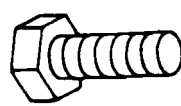
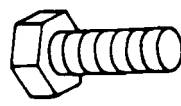
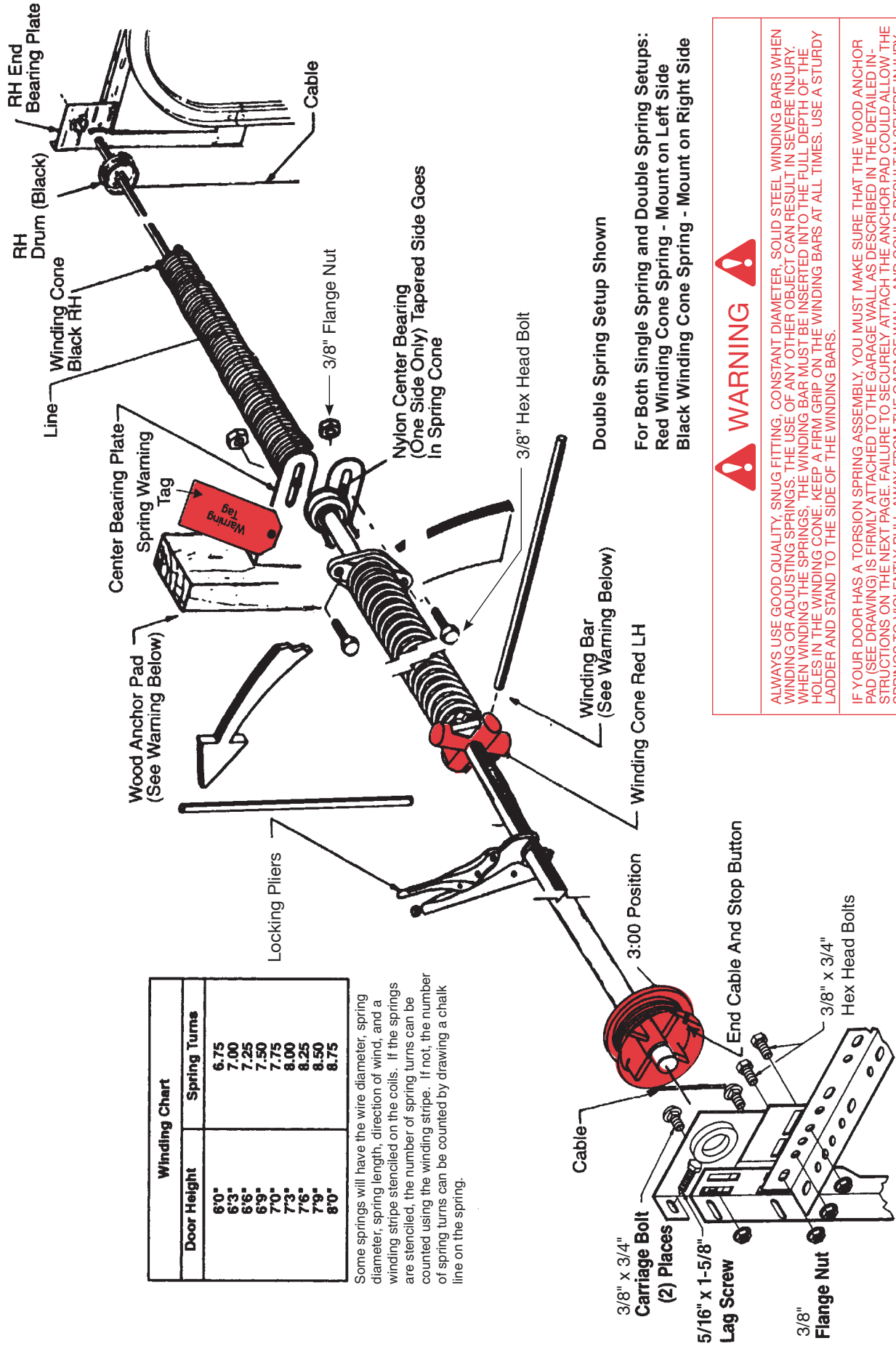

Table TOR-1

DESCRIPTION	DOOR SIZE	QTY.
 TORSION SPRING	Single Car Doors 8' - 9' W x 7' H	1
	Double Car Doors 16' W x 7' H	1 or 2
 END BEARING PLATE	Single Car Doors 8' - 9' W x 7' H	2
	Double Car Doors 16' W x 7' H	2
 TORSION TUBE	Single Car Doors 8' - 9' W x 7' H	1
	Double Car Doors 16' W x 7' H	1
 CENTER BEARING PLATE	Single Car Doors 8' - 9' W x 7' H	1
	Double Car Doors 16' W x 7' H	1
 CABLE DRUMS	Single Car Doors 8' - 9' W x 7' H	2
	Double Car Doors 16' W x 7' H	2
 NYLON CENTER BEARING	Single Car Doors 8' - 9' W x 7' H	1
	Double Car Doors 16' W x 7' H	1
 5/16" X 1-5/8" LAG SCREW	Single Car Doors 8' - 9' W x 7' H	2
	Double Car Doors 16' W x 7' H	2
 5/16" X 1-5/8" LAG SCREW (RED HEAD)	Single Car Doors 8' - 9' W x 7' H	2
	Double Car Doors 16' W x 7' H	2
 3/8" X 3/4" HEX HEAD BOLT	Single Car Doors 8' - 9' W x 7' H	4
	Double Car Doors 16' W x 7' H	4
 3/8" FLANGE NUT	Single Car Doors 8' - 9' W x 7' H	10
	Double Car Doors 16' W x 7' H	10
 3/8"-16 X 3/4" CARRIAGE BOLT	Single Car Doors 8' - 9' W x 7' H	4
	Double Car Doors 16' W x 7' H	4
 3/8" X 1" HEX HEAD BOLT	Doors With One Spring	2
	Doors With Two Springs	0
 3/8" X 1-5/8" HEX HEAD BOLT	Doors With One Spring	0
	Doors With Two Springs	2

Torsion Spring Installation



Door Height	Spring Turns
6'0"	6.75
6'3"	7.00
6'6"	7.25
6'9"	7.50
7'0"	7.75
7'3"	8.00
7'6"	8.25
7'9"	8.50
8'0"	8.75

Some springs will have the wire diameter, spring diameter, spring length, direction of wind, and a winding stripe stenciled on the coils. If the springs are stenciled, the number of spring turns can be counted using the winding stripe. If not, the number of spring turns can be counted by drawing a chalk line on the spring.

Double Spring Setup Shown
 For Both Single Spring and Double Spring Setups:
 Red Winding Cone Spring - Mount on Left Side
 Black Winding Cone Spring - Mount on Right Side

WARNING

ALWAYS USE GOOD QUALITY, SNUG FITTING, CONSTANT DIAMETER, SOLID STEEL WINDING BARS WHEN WINDING OR ADJUSTING SPRINGS. THE USE OF ANY OTHER OBJECT CAN RESULT IN SEVERE INJURY. WHEN WINDING THE SPRINGS, THE WINDING BAR MUST BE INSERTED INTO THE FULL DEPTH OF THE HOLES IN THE WINDING CONE. KEEP A FIRM GRIP ON THE WINDING BARS AT ALL TIMES. USE A STURDY LADDER AND STAND TO THE SIDE OF THE WINDING BARS.

IF YOUR DOOR HAS A TORSION SPRING ASSEMBLY, YOU MUST MAKE SURE THAT THE WOOD ANCHOR PAD (SEE DRAWING) IS FIRMLY ATTACHED TO THE GARAGE WALL AS DESCRIBED IN THE DETAILED INSTRUCTIONS ON THE NEXT PAGE. FAILURE TO SECURELY ATTACH THE ANCHOR PAD COULD ALLOW THE SPRINGS TO VIOLENTLY PULL AWAY FROM THE GARAGE WALL, AND COULD RESULT IN SEVERE INJURY AND/OR PROPERTY DAMAGE. IN NO CASE SHOULD NAILS BE USED.

Fig.TOR-2

Step 1



WARNING

It is important that the torsion spring assembly be firmly and securely attached to the frame of the garage.

Refer to Figure TOR-1 on page 1 for the configuration of 2" x 6" wood jambs. **Important:** The wood anchor pad must be made of a Grade 2 or better southern yellow pine (also known as southern pine or yellow pine). Other acceptable types of wood for this application are beech, birch, hickory, and oak. The wood must be free of splits and cracks. **Do not use wood labeled as spruce pine fir (or SPF).**

Each side jamb and the center anchor pad should extend 12" above the top of the opening for 12" radius horizontal track and 15" above the top of the opening for 15" radius horizontal track.

The wood anchor pad must be attached to the frame of the garage with at least four 3/8" x 4" long lag screws for wooden frames or four 3/8" x 4" long sleeve anchors for concrete frames. (one at each corner). The four fasteners must be installed no closer than 1-1/2" from the sides and the ends of the anchor pad. These fasteners must be embedded into the frame of the garage, not the drywall or sheet rock. The wood anchor pad and fasteners are not supplied. **Do not use nails.**

NOTE: The wood anchor pad can be off-center to the width of the opening by up to 10" in either direction.

Step 2



WARNING

Lock the door in the down position securely using door lock or locking pliers. This must be done to prevent the door from prematurely opening which could cause an injury.

NOTE: You need an assistant in Step 4. If your garage has only one entrance, be sure you, the assistant, and the tools you need are inside before you lock the door. Your door will have either one or two torsion springs. Each torsion spring consists of spring coils, stationary cone, and a winding cone (FIG. TOR-2). Some springs will have the wire diameter, spring diameter, spring length, and direction of wind stenciled on the coils and the winding cone is color coded separately, either red or black (Fig. TOR-3). The color on the winding cone is to help identify on which side of the door the spring is to be used.

The black winding cone torsion springs with "LW" are used on the right side of the door and red winding cone torsion springs with "RW" are used on the left side of the door when viewing the door from the inside looking out. Failure to install the torsion springs on the correct side will cause your door to function improperly and could result in serious injury. (NOTE: If you have low headroom, these instructions DO NOT APPLY. Consult supplemental low headroom instructions.)

Slip the torsion springs onto the spring tube, the red winding cone torsion spring marked with "RW" on the left end, the nylon center bearing, center bearing plate, and the black winding cone torsion spring marked with "LW" on the right end (FIG. TOR-3). Cable drums go on next, the red drum on the left, black drum on the right. The set screws on the drums face the springs.

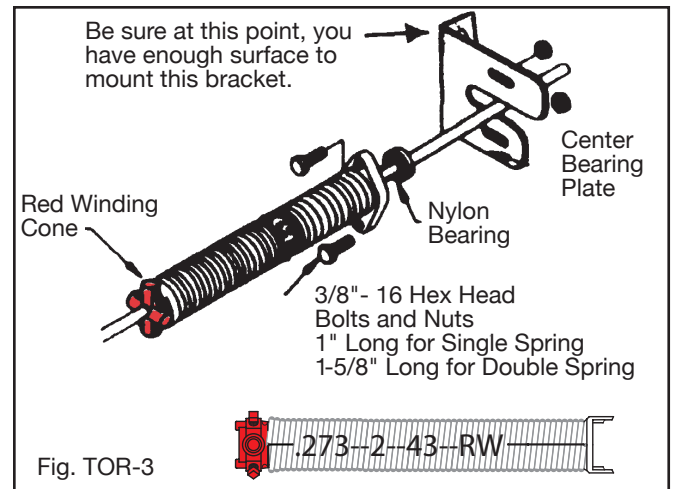

Step 3

Bend and break apart end bearing plates by hand at tabs as shown (FIG. TOR-4A). Fasten the bottom of the end bearing plate to the horizontal angle with (2) 3/8" x 3/4" long hex head bolts and hex nuts. The bottom of the end bearing plate is identified by two parallel rows of two slots. Please make sure to use the bottom two slots for 12" radius horizontal track, and the upper two slots for 15" radius horizontal track. When properly mounted the torsion tube is level and straight (FIG. TOR-4).

Before installing any lag screws, it is important to drill 3/16" pilot holes where the lag screws are to be attached. Fasten the wall flange on the end bearing plate to the wood jamb with (1) 5/16" x 1-5/8" long lag screw. Drill 3/16" pilot holes where lag screws are to be installed. On 12" radius horizontal track, each end bearing plate should also be attached with 3/8" x 3/4" carriage bolts and 3/8" nuts (FIG. TOR-4).

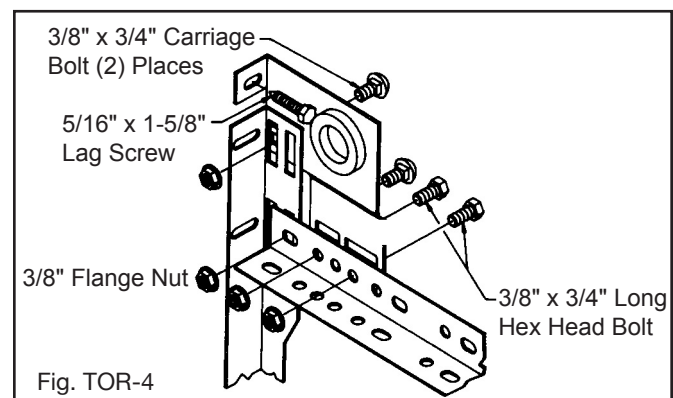
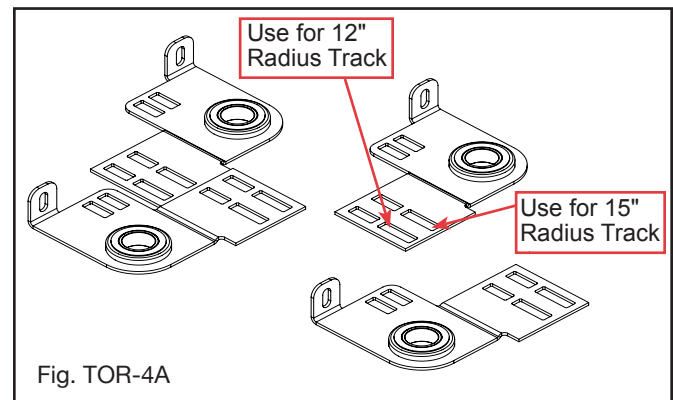

Step 4

With an assistant, lift the complete torsion spring tube assembly and slide the ends of the tube into the bearing on the end bearing plates. With the tube level, mount the center bearing plate to the center anchor pad using (2) 5/16" x 1-5/8" long lag, red-coated screws.

NOTE: Red-headed fasteners must be installed for the attachment of center bearing plate to indicate this part will be under extreme tension once spring is wound (FIG. TOR-5).

Before mounting the center bearing plate, drill (2) 3/16" pilot holes for the lag screws. These pilot holes must be no closer than 1-1/2" from the sides and ends of the wood anchor pad. The center bearing plate resists the considerable counter torque of the springs. This wood anchor pad must be installed to the frame of the garage as stated in **Step 1**.

Step 5

The cable that is attached to each bottom bracket is brought up between the wall and roller shafts to the cable drum. This cable is placed in the notch on the cable drum. Turning the cable drum and sliding it up tight against the end bearing plate removes the cable slack. **Make sure the cable follows the grooves in the cable drum.** The set screws on the cable drum should be tightened with a 3/8" box wrench while holding the cable taut. Locking pliers clamped to the torsion spring tube maintain tension on the cable (FIG. TOR-2). This procedure should be repeated on the opposite side.

Step 6

The following instructions apply to both galvanized and oil-tempered springs. Oil-tempered springs are dark in color. Galvanized springs have a bright zinc (silver-colored) coating.

The stenciled description can be used as a straight line to indicate the number of turns on the spring(s). If there is no straight line present, make one with a piece of chalk. After inserting the two winding bars all the way into the winding cone, wind the springs 1/4 turn at a time in an upward direction as shown in FIG. TOR-5. The number of turns is shown in the table in FIG. TOR-2. The tail of the torsion spring coil points in the direction that the spring is wound (FIG. TOR-5A).



WARNING

NEVER use screwdrivers or other substitutes for winding bars! Stand to the side of bars. Be sure to insert the bars all the way into the hole.

TIP: The balance of the door may differ slightly depending on whether galvanized or oil-tempered springs are provided. If galvanized springs are provided, the initial balance of the door may appear slightly "hot" (door drifts upward) with the turns specified in the table in FIG. TOR-2. The spring(s) will self adjust and reflex slightly, resulting in a balanced door within a few weeks of normal operation. To accelerate this effect at the time of installation, proceed to wind the spring two extra full turns past the number of turns shown in the table in FIG. TOR-2. Next, carefully unwind the two extra full turns until the spring(s) equal the number of turns in the table.

Secure each spring with the set screws on the winding cone. (**Caution:** Set screws should be turned from 3/4 to one full turn after they have made contact with the tube.) On doors with two torsion springs, each torsion spring should be wound the same number of turns. Remove the locking pliers.

Step 7

Unlock the door, slowly raise the door and prop it about halfway open.



WARNING

This is the first time the new door is being opened. If the tracks are not correctly aligned or the back hangers are not strong enough, the door may fall. Proceed slowly and carefully.

Check to be sure the horizontal tracks are parallel with each side of the door. Make sure all the lag screws are securely fastened. With the door about halfway open, make sure the rollers do not come out of the top brackets more than about 1/2 inch. If adjustment of the rear track hanger is necessary, the door must be locked in the closed position because the weight of the door is supported by the rear hangers.

NOTE: If the torsion springs do not increase in tension as the 1/4 turns are added to the springs, then you probably have the torsion springs reversed. (See **Step 2**.)

Step 8

To adjust torsion spring tension, the door is locked in the down position. With locking pliers clamped on the torsion tube, winding bars are used to wind the springs tighter to increase tension. Tension is reduced by removing turns. When two springs are used, both sides should be adjusted the same. Adjustments should be made in 1/4 turn increments.



WARNING

NEVER adjust center bearing plate or red-headed fasteners after springs are wound. Be prepared to handle a strong force when reducing tension on a torsion spring. Use winding bars only, and stand to the side.

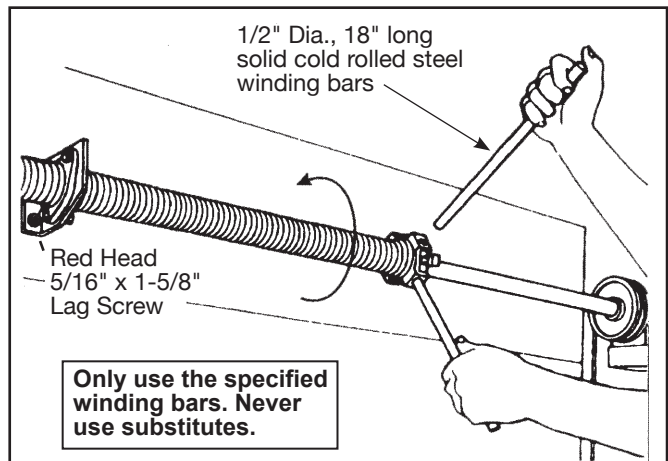

Fig. TOR-5

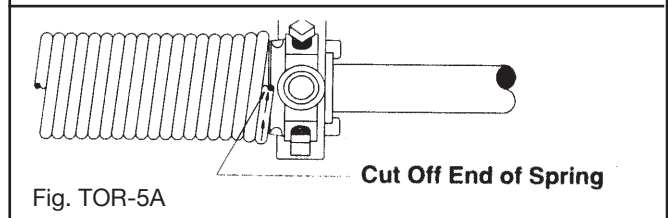

Fig. TOR-5A