

COMMERCIAL & INDUSTRIAL
SLEEK ALUMINUM SECTIONAL DOORS

INSTALLATION & MAINTENANCE

COMMERCIAL HOTLINE • 1-800-526-4301



Models: 905, 906, 905U, 906U Serial No. _____

(Provided on label on interior door surface)

Size: _____

Dear Clopay Customer,

Thank you for purchasing a Clopay Garage Door. Your new Clopay Garage Door was built to meet the highest industry standard and to provide you with years for dependable performance. This manual contains important safety, installation and maintenance instructions. Carefully follow the Instructions and Maintenance recommendations. Please keep this manual for future reference. If you should require any assistance or additional information, please call the hotline number on the cover of this manual.

Thank you again for choosing Clopay!

Sincerely,
Clopay Corporation



TABLE OF CONTENTS

Introduction and Opening Preparation

Safety Information	3
Things to Know Before You Begin	4
Additional Material Needed (Not Included).....	5
Removing the Existing Door	5
Preparing the Opening	6

Installing the New Door

Preparing and Installing Door Sections	9
Hinge and Top Bracket Attachment	13
Door Reinforcement Attachment	14
Track Installation	16
Back Hang Requirements.....	18
Spring Installation	22
Spring Winding	23

Maintenance/Adjustments/Options

Final Adjustment and Maintenance	27
Cleaning and Preserving the Door	27
Painting.....	28
Window Care and Replacement.....	28
Attaching an Automatic Jackshaft Opener.....	28
Cable Snubber and Pusher Spring.....	29

SAFETY INFORMATION

IMPORTANT!



To Protect Yourself from Injury, Carefully Read the Following Safety Information and Warnings Before You Install or Attempt To Repair Your New Garage Door.



- You can install your new garage door yourself IF...
 - a) you have help (weight can vary from 150 lbs. [70 kg] up to 2,000 lbs. [900 kg]);
 - b) you have the right tools and reasonable mechanical aptitude or experience; and
 - c) you follow these instructions very carefully.In particular, please note that:
 - Garage doors use springs to balance them. Generally, there are two types of springs used — **extension or torsion springs**. **If your old door uses torsion springs, do not attempt to remove the door or the springs yourself.** Have a qualified door repair service remove them. Attempting to remove a torsion spring assembly and/or any red-colored fasteners without proper training or tools may result in an uncontrolled release of spring forces which can cause serious or fatal injury.
 - The brackets at the bottom corners of your garage door are under great tension. **Do not attempt to loosen any bracket fasteners** and/or any red-colored fasteners except when and as directed in detail in the following instructions. Otherwise, the bracket could spring out with dangerous force.
 - When installing a door with torsion springs, always use solid steel winding bars. Winding bars are available from many professional door installers. **The use of screwdrivers or any substitutes for winding bars will risk severe injury.** See "Spring Winding" for further safety instructions regarding winding bars.
 - Keep hands and fingers clear of section joints, track and other door parts when the door is opening and closing to avoid injury. The lift handle and pull down rope are located for safe operation as well as easy use.
 - **Extension spring doors must never be operated without a properly installed spring containment cable.**
 - 3/8" [10 mm] Hex Head Bolts must be installed at the rear end of horizontal tracks. These act to stop the rollers and keep the door from rolling off the back of the track.
 - **Only the track and hardware specified and supplied with the door should be used.**
 - Express warranties apply only to doors installed using original, factory-supplied sections, parts, and hardware installed in strict accordance with these instructions.
 - Track installations must use sway braces on the rear track hangers to prevent sideways movement. If the tracks are not firmly stabilized, they might spread, allowing the door to fall and cause severe injury and damage.
- The torsion spring assembly uses one (1) wooden pad (2" × 6" × 12" [51 mm × 152 mm × 305 mm] minimum) or steel plate (1/4" × 10" × 12" [6 mm 254 mm × 305 mm] minimum) per spring anchor bracket, that **must be of good quality and firmly attached to the wall.** Four 3/8" × 3" [10 mm × 76 mm] lag screws should be used to attach to a wood structure. The wood needs to be made of a Grade 2 or better Southern Yellow Pine (also known as Southern Pine or Yellow Pine.) **DO NOT** use wood labeled as Spruce-Pine-Fir (or SPF). Four 3/8" [10 mm] masonry anchors can be used on concrete or block walls. If the wood splits once the torsion spring is in place, it should be replaced by a professional installer. **Do not try to remove or repair a torsion spring assembly or any red-colored fasteners once it is wound.**
- **Springs, cables and bottom brackets are under extreme spring tension. Do not attempt to loosen any fasteners on these components.** You could suddenly release spring forces and risk severe injury.
- If the garage door and/or any of the supporting track are damaged, operating the door could be hazardous. Call an authorized representative of the manufacturer or professional door repair service promptly.
- **Do not permit children to play beneath or with any garage door or electric operating controls.**
- If repairs are ever required to your door, safety and trouble-free operation can be best assured by using original replacement parts.
- Once you have completed the installation of your new garage door, please be sure that your garage complies with all applicable ventilation requirements before you enclose any vehicles in the garage. Good ventilation avoids fire and health hazards caused by fumes accumulating within a well-sealed garage.
- The manufacturer disclaims all liability for any installation which is not in compliance with applicable state, county or local building codes.
- Doors equipped with automatic door operators can cause serious injury or death if not properly adjusted and operated. To ensure safe operation of these doors:
 - a) test the sensitivity of the operator's safety reverse mechanism monthly;
 - b) remove the pull rope;
 - c) make sure the door remains unlocked;
 - d) do not allow children to play with the controls.

THINGS TO KNOW BEFORE YOU BEGIN

Read the instructions completely before starting installation of the door. Becoming familiar with the components before assembling the door will reduce the installation time.

⚠ WARNING **⚠ CAUTION**

In the interest of safety these symbols mean WARNING or CAUTION. Personal injury and/or property damage may occur unless instructions are followed carefully.

- To avoid damage to the door, you must reinforce the top section of the door in order to provide a strengthened mounting point for attachment of an automatic opener. Refer to "Attaching an Automatic Jackshaft Operator".
- Check clearance requirements in the chart below before beginning.

⚠ WARNING

Springs and related hardware are under EXTREME tension and could cause SEVERE INJURY OR DEATH if mishandled. DO NOT ATTEMPT TO REPAIR OR ADJUST the springs, red fasteners, hardware or structure to which they are attached.

IMPORTANT!

Before Starting Installation:

Step 1: Opening Size. Check the opening size and verify that the door is the proper size for the opening. Wood jambs require the door to be the same size as the opening with stop moldings nailed to the inside of the opening to seal the door. Steel or masonry jambs require the door to be two-inches wider than the opening to allow a one-inch door overlap on each side. No stop moldings are required in this application. The opening must be plumb and square to assure a good fit.

Step 2: Material Check. Check all materials with the hardware box and spring box labels. Any report of shortages must be accompanied by the contract number. Report the number of pieces received along with the number of pieces short. Springing information, including the number of turns to wind spring, can be found on the hardware box label.

Step 3: Space Requirements. Check for sufficient headroom and side room. The chart below contains standard minimum clearance requirements. Headroom is the distance between the top of opening to the ceiling or the lowest obstruction.

Step 4: Red Fasteners. The hardware package supplied with your door should include red fasteners for attachment of the torsion spring center bracket and/or the bottom roller brackets. These fasteners must be securely attached as indicated in the installation manual.

Standard Minimum Clearance Requirements

	Headroom ^{*, **, †, ††}		Sideroom ^{*, †}		Backroom	
	2" [51 mm] Track	3" [76 mm] Track	2" [51 mm] Track	3" [76 mm] Track	2" [51 mm] Track	3" [76 mm] Track
12" [305 mm] Radius	14-1/2" [368 mm]	N/A	4-1/2" [114 mm]	N/A	Door Ht. + 23" [584 mm]	N / A
15" [381 mm] Radius	16" [406 mm]	18" [457 mm]	4-1/2" [114 mm]	5-1/2" [140 mm]	Door Ht. + 23" [584 mm]	Door Ht. + 25" [635 mm]
High Lift	High Lift + 12" [305 mm]	High Lift + 12" [305 mm]	4-1/2" [114 mm]	5-1/2" [140 mm]	Varies	Varies
Vertical Lift	Dr. Ht. + 12" [305 mm]	Dr. Ht. + 12" [305 mm]	4-1/2" [114 mm]	5-1/2" [140 mm]	23" [584 mm]	25" [635 mm]

* Doors over 18' [549 cm] high, over 1,000 lbs. [454 kg] springing weight or high cycle springs may require additional headroom and sideroom. Consult distributor for exact requirements.

** Doors with more than one row of springs require additional headroom.

† Chain hoist and electric operators require additional clearance. See instructions provided with operator for exact amount.

†† Vertical lift doors with straight incline require additional headroom. Contact factory.

ADDITIONAL MATERIALS NEEDED (NOT INCLUDED)

General

- One (1) can of Clopay® Pro Lube
- 10d 3" common nails
- Stop molding
- Wood shims
- Wood block
- Rope

Back Hang (Rear Track Hanger) Specific:

- Rear Track Hanger kit or material to make rear track hangers (see below):
 - 1-1/4" × 1-1/4" × 13 ga. min. thickness punched angle
 - 3/8" × 1" bolts and nuts
 - 5/16" × 1-5/8" lag screw

Tools Needed (Not Included)

- Safety glasses
- "C" clamps or locking pliers
- Hammer
- Winding bars (torsion only)
- Flathead and phillips screwdriver
- Tape measure
- Level
- Socket wrench kit
- Allen wrench set
- Pliers
- Ladder
- Drill and complete drill bit set
- Sawhorses or other supports for placing section on while assembling
- Pencil/pen/marker
- Chalk/chalk line
- Hacksaw
- Wood saw
- Angle square
- Additional tools may be required for spring installation

REMOVING THE EXISTING DOOR

Step 1: Remove Existing Door Springs.

NOTE: Garage doors use springs to balance door weight. Springs are one of two types – extension or torsion. Each of these is available in either a standard or EZ-SET® assembly option.

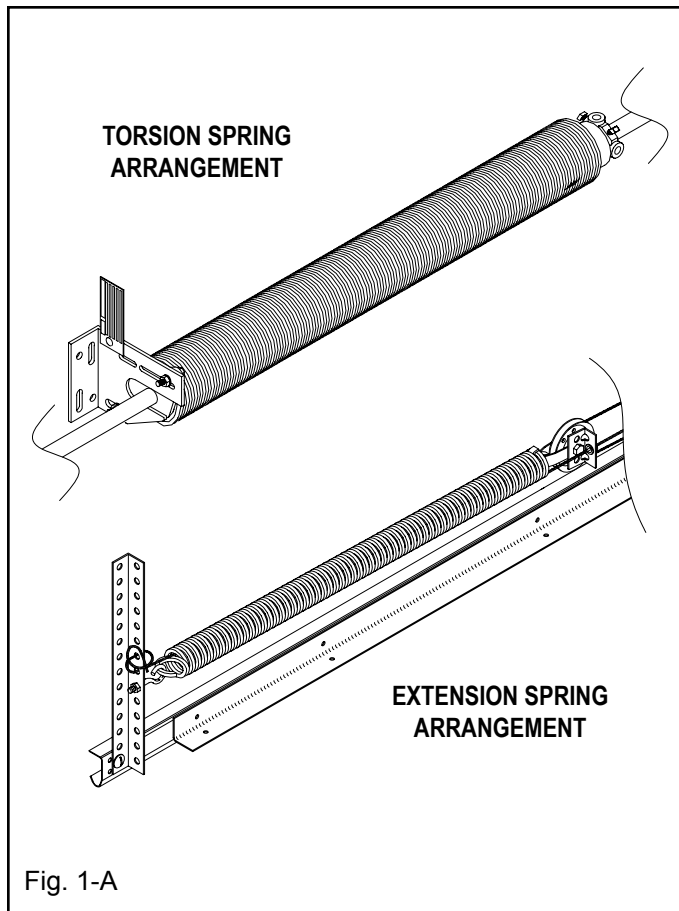

Fig. 1-A

Use illustrations in Fig. 1-A to determine which springs existing door has. If existing door's spring type is not found, please consult spring manufacturer.

⚠ WARNING

Serious injury could result from an uncontrolled release of spring forces if spring tension has not been released before other work begins.

⚠ WARNING

To avoid pinch and other crushing injuries, keep hands and fingers clear of section joints, track and other door parts while door is opening and closing.

NOTE: Some large doors can weigh as much as 500 lbs. and single car doors as much as 200 lbs. when spring tension is removed.

Standard Torsion Springs:

⚠ WARNING

If present door uses standard torsion springs, DO NOT attempt to remove door or springs yourself. They should be removed by a qualified door service professional. Attempting to remove a torsion spring assembly without proper training and tools may result in an uncontrolled release of spring forces which can cause serious injury.

Standard Extension Springs:

⚠ WARNING

Extension adjustments or removal should only be made with door in up position. To avoid damage or serious injury from door falling, use two or more helpers to assist in lowering door.

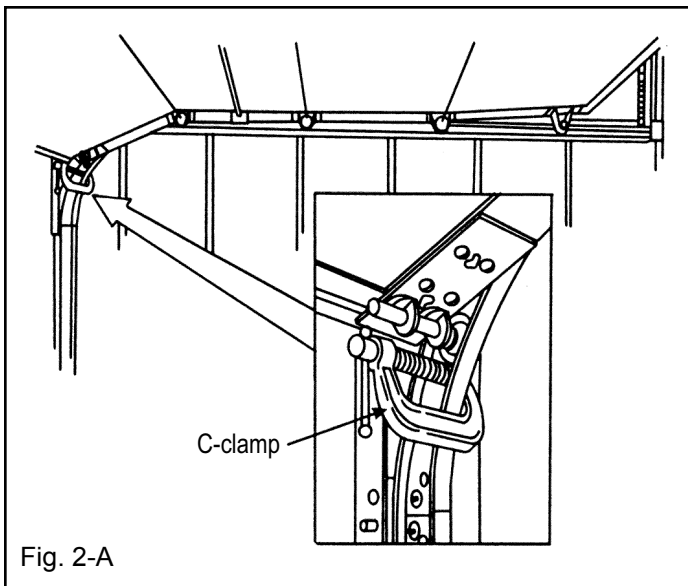

Fig. 2-A

Raise door to full open position. Place C-clamps or locking pliers tightly on both sides of track under door so door is held securely in place (Fig. 2-A). With door fully open, most spring tension has been removed. Keeping C-clamps in place to keep door from falling, detach cable at both ends. Disassemble and remove springs and cable completely from door.

NOTE: Wood blocks should be placed underneath door when closing to prevent fingers from being trapped.

Remove C-clamps from track and carefully close door. Weight of door will not be apparent when you first begin to close door. Door will feel progressively heavier as it is lowered until its full weight is realized about one foot from floor.

EZ-SET® Extension Springs or EZ-SET® Torsion Springs:

⚠ WARNING

To avoid damage or serious injury, use two or more helpers to assist in lowering door. EZ-SET® torsion springs adjustments or removal should only be made with door in down position.

With door in down position, position drill with 7/16" socket bit over winding unit. Using reverse (counter-clockwise) direction on drill, remove all tension from spring. Repeat for each side. After spring tension has been removed, detach lift cables at both ends. Disassemble and remove springs and cable completely from door.

Step 2: Remove Door Sections and Track

After removal of door springs, door can now be disassembled. Starting with top section, remove hardware and unstack sections one at a time (Fig. 3-A). After all sections have been removed from opening, detach all remaining track and hardware from jambs. Hangers that attach rear ends of overhead track to ceiling (rear track hangers) in many cases can be reused on new door. Be sure they are made of 13 ga. (3/32") or heavier steel and are not loose or unstable.

⚠ WARNING

To avoid installation and operation problems from using worn, damaged or incompatible track, use only track specified and supplied with door. DO NOT attempt to reuse old track.

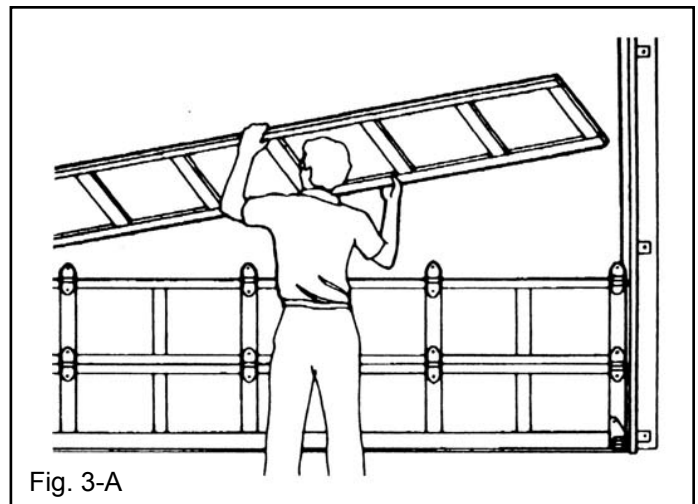
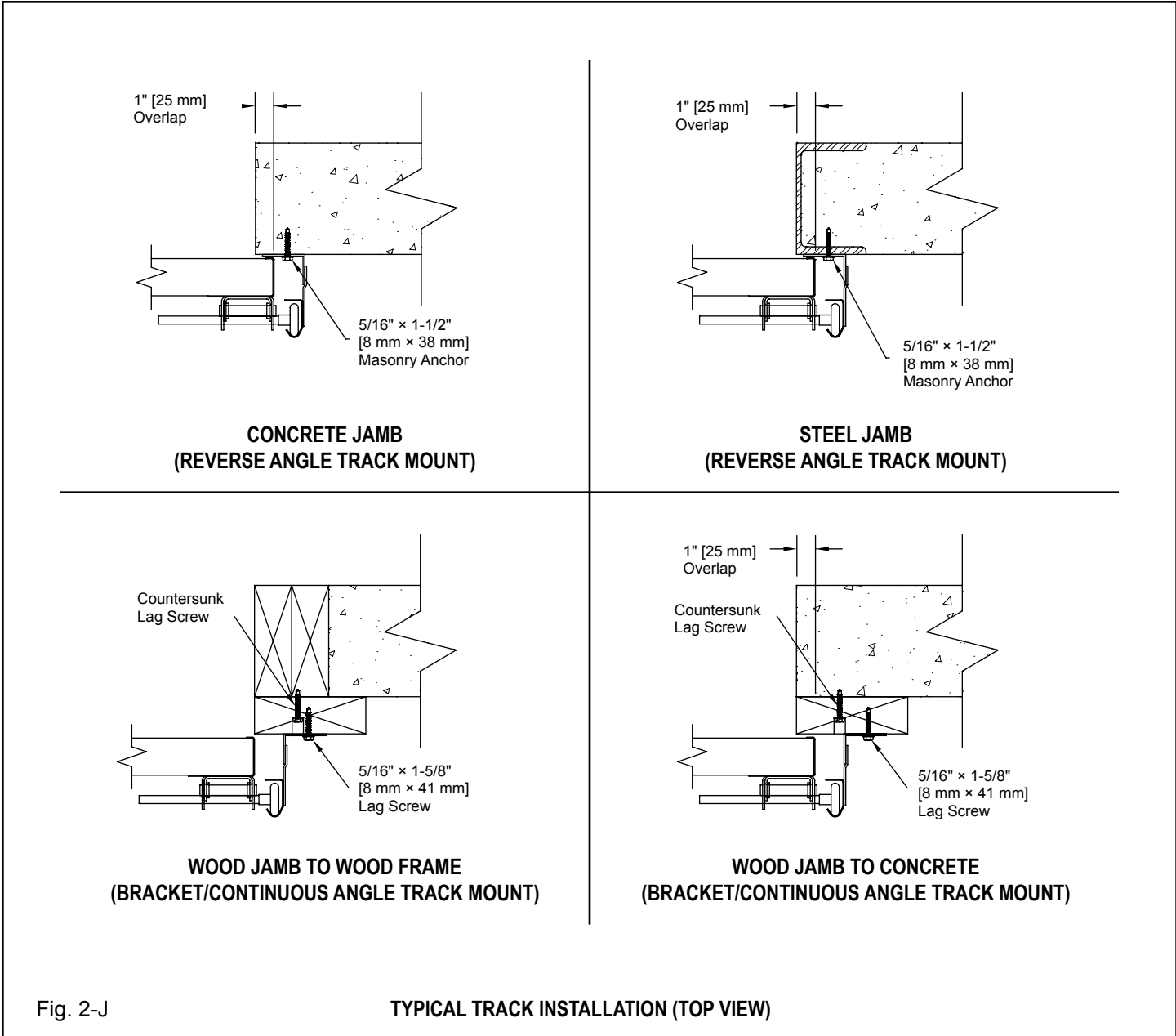
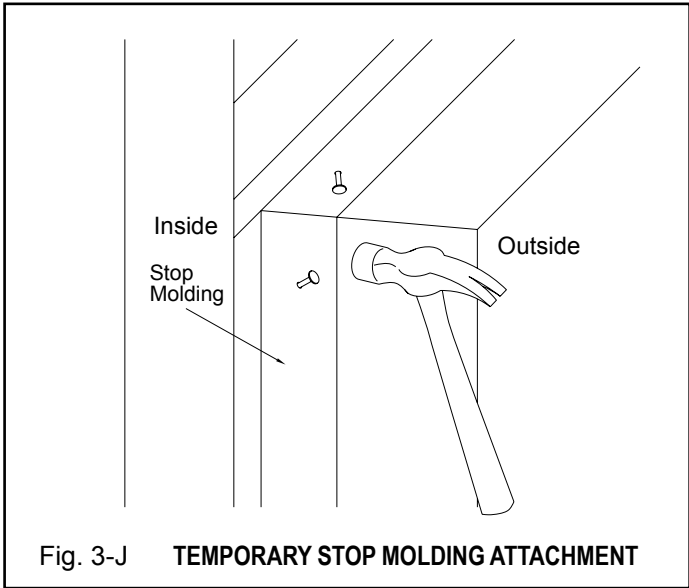
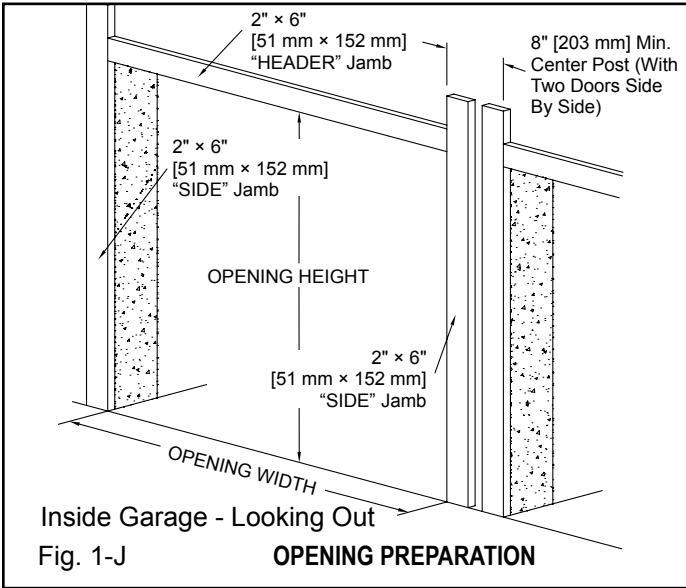

Fig. 3-A

PREPARING THE OPENING

Step 1: Door Frame. On the inside of your opening should be framed with wood jambs, 2" x 6" [51 mm x 152 mm] if possible or with steel channel. The side jambs should extend to approximately the same height as the headroom required. If you have just removed an old door, the condition of the jambs should be inspected. If the jamb has deteriorated, it should be replaced now. The jambs should be plumb and the header level. If there are any bolts fastening the jambs to the wall the heads should be flush so they don't interfere with the installation of your new door (Fig. 1-J). Typical installation for wood, steel or masonry jamb material is shown in Fig. 2-J.

Step 2: Stop Molding. Door stop molding for wood jambs should be temporarily nailed to the edges of the jambs flush with the inside (Fig. 3-J). Since steel jambs require the door to be 2" [51 mm] wider than the opening, no stop molding is required. Stop molding featuring a built-in weather seal is offered as an option.



⚠ WARNING

Failure to use red-colored fasteners for attachment of bottom brackets may cause sections to fall or spring to break free when spring tension is applied, which can result in severe injury.

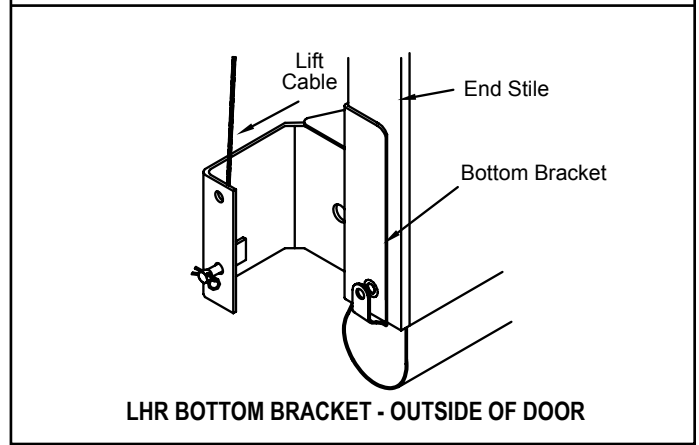
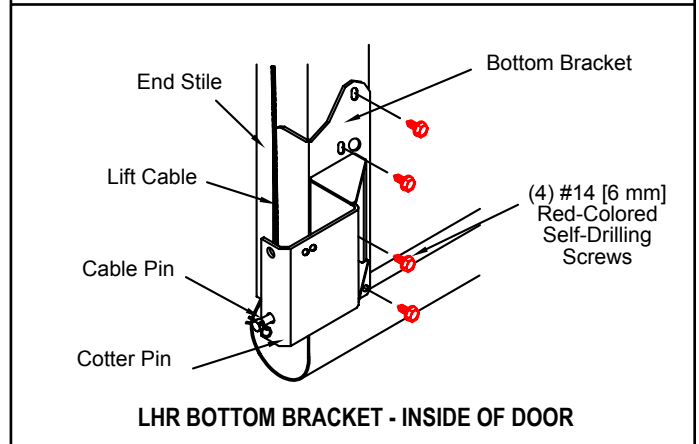
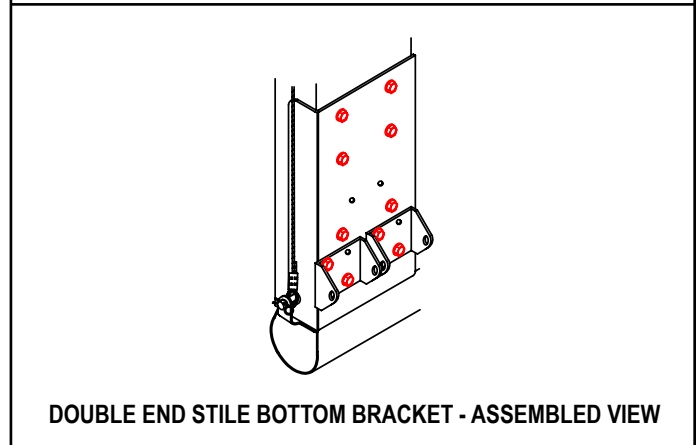
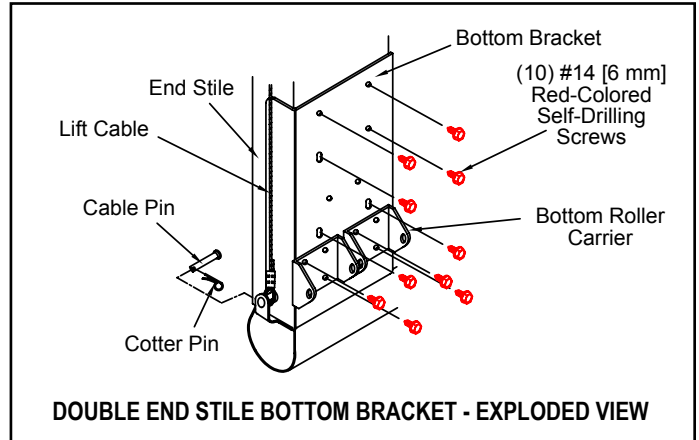
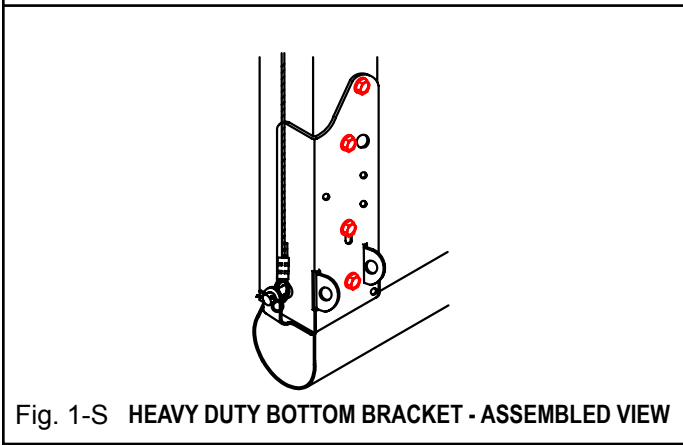
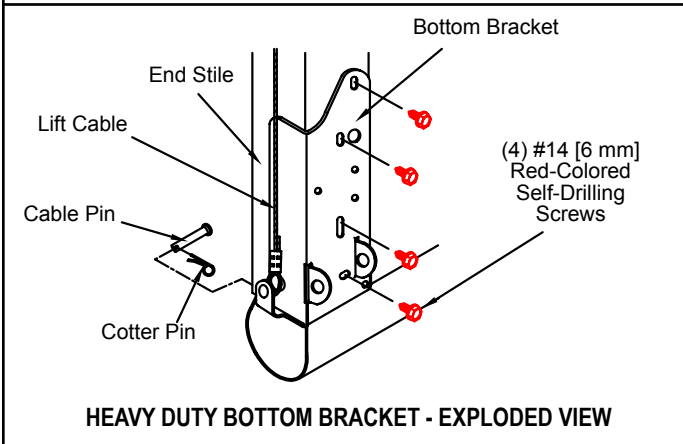
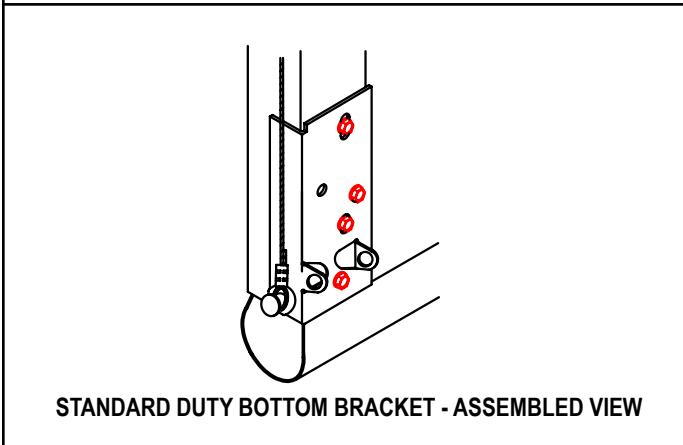
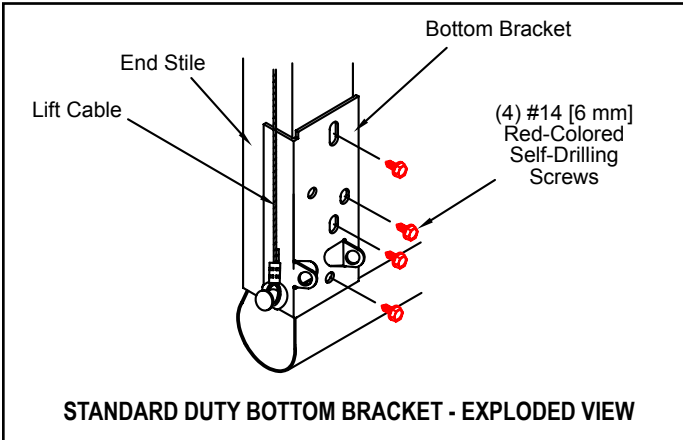

Fig. 1-S HEAVY DUTY BOTTOM BRACKET - ASSEMBLED VIEW

PREPARING AND INSTALLING DOOR SECTIONS

Step 1: Bottom Section. Find bottom section (the one with bottom weather seal), then lay it face down on sawhorses ensuring it is properly supported. Find bottom bracket in hardware carton. Several different types are used depending on door thickness, door weight and track size. Fasten bottom bracket using the red-colored fasteners (Fig. 1-S).

Some have flanges which hook under the bottom section and some do not. If the bracket has a flange, slit the inside leg **ONLY** of the bottom weather seal approximately 1-1/2" [38 mm] to allow for bracket attachment. Install cables on bottom bracket, then position the bracket in place (Fig. 1-S).

IMPORTANT: Do not cut cables. It may seem like the cables are too long, but they are not. Wind the extra cable onto the drums.

Install hinges on end stiles and at pre-drilled center locations of the bottom section. Refer to "Hinge and Top Bracket Attachment" for instructions.

Install reinforcement angle/strut/channel, if supplied. Refer to "Door Reinforcement Attachment" for instructions. Stack bottom section in opening. **Long stem rollers provided go into bottom brackets.** Temporarily install vertical track as described in "Track Installation". Top rollers will hold section in place.

Step 2: Step Plate/Lift Handle Installation. Install interior lift handle/step plate to the bottom rail nearest the center of the door using two (2) #14 × 5/8" [6 mm × 16 mm] self-drilling screws (Fig. 2-S).

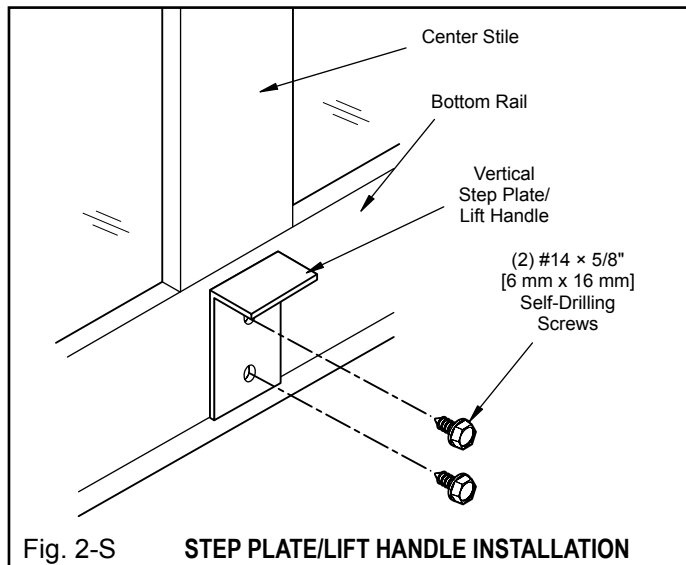

Step 3: Exterior Lift Handle Installation. Cut out template found on page 11 and on the front side of the bottom section, use it to mark and drill two (2) 9/64" [4 mm] holes on the bottom rail at the center of the section. **DO NOT** drill all the way through the door section.

Using a Philips head screwdriver, install two (2) handle studs at drilled hole locations using two (2) #10 × 1" [5 mm × 25 mm] pan head sheet metal screws (Fig. 3-S).

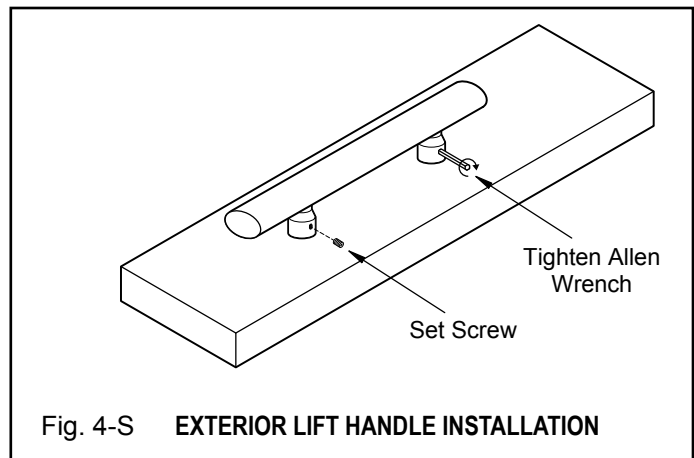
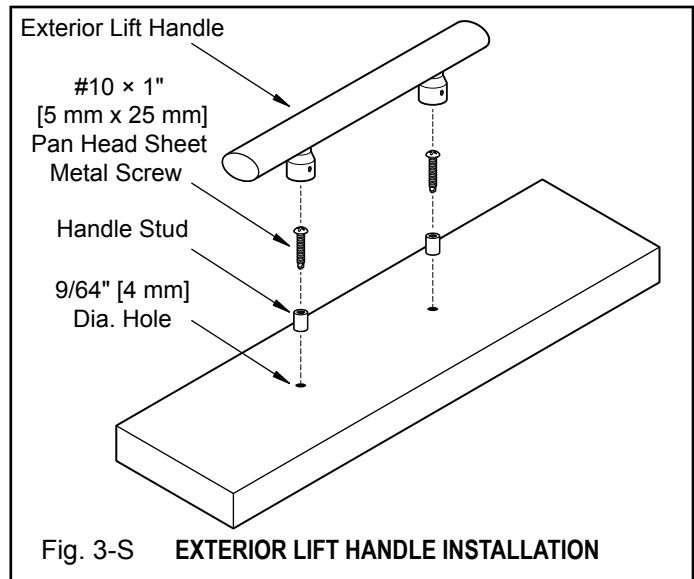

Place outside exterior lift handle over handle studs (Fig. 3-S).

Use a 3/32" [2 mm] Allen wrench to attach exterior lift handle to studs using 3/16" set screws (Fig. 4-S).

Step 4: Second and Third Section. Attach hinges to section. Refer to "Hinge and Top Bracket Attachment" for instructions. Attach reinforcement angle/strut/channel, if supplied. Refer to "Door Reinforcement Attachment" for instructions. If section has lock, see Step 5 for sequence. Stack section. After section is stacked, rollers in track will hold section in place.

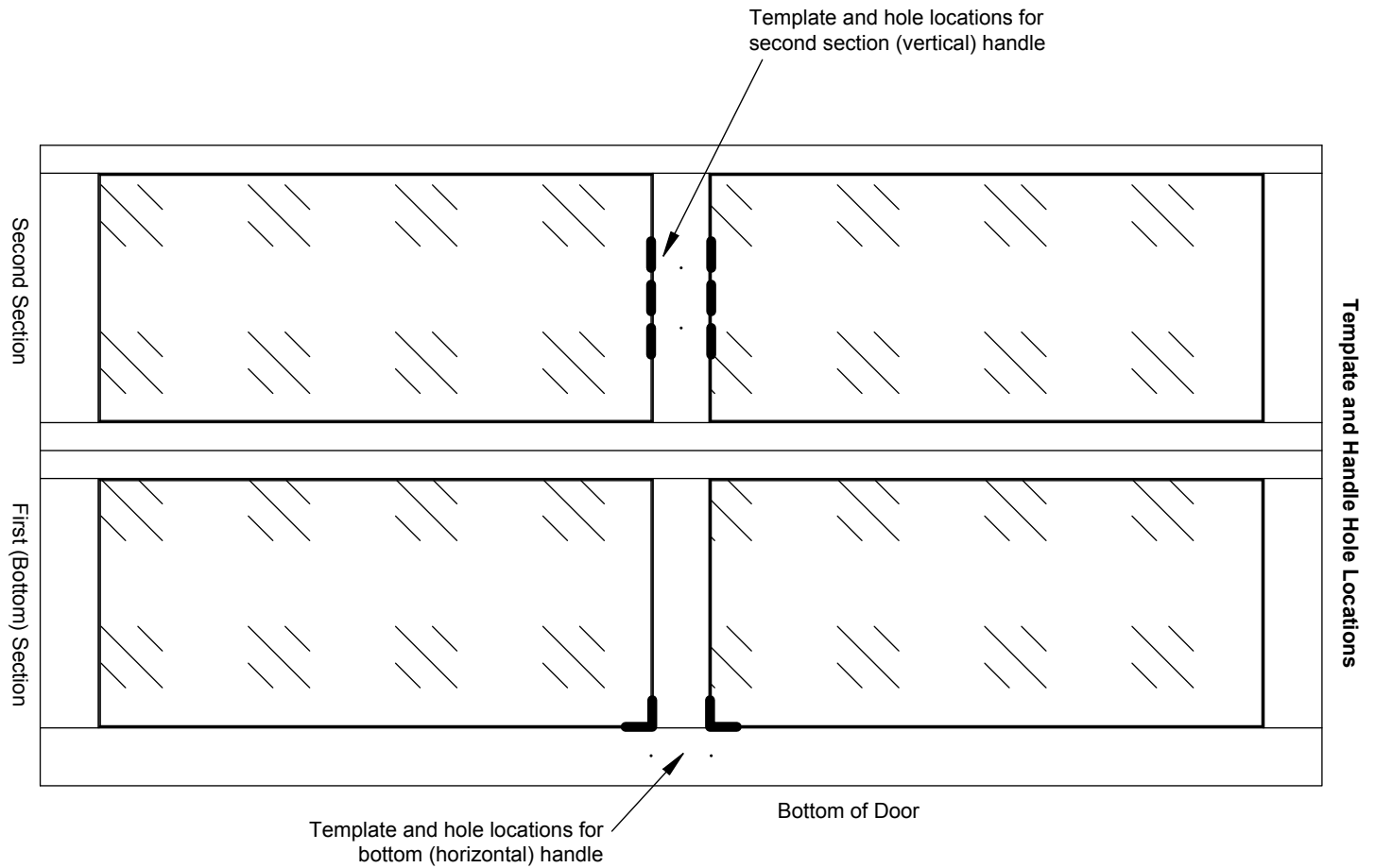

Step 5: Lock Installation. The standard location for the locking system (if provided) is on the third section and should be installed prior to stacking additional sections. The following locking systems are available for aluminum doors:

- Inside Slide Bolt

Inside Slide Bolt: Locate rectangular engaging slots in either vertical track. Attach inside bolt assembly to end stile using #14 × 5/8" [6 mm × 16 mm] self-drilling screws. The slide bolt must rest against the top of the engaging slot (Fig. 5-S).

Step 6: Fourth Section and Up (Does not include top section). Place section face down on sawhorses. Attach hinges to section. Refer to "Hinge and Top Bracket Attachment" for instructions. Attach reinforcement angle/strut/channel, if supplied. Refer to "Door Reinforcement Attachment" for instructions. After section is stacked, rollers in the track will hold section in place.

Continue to stack and install remaining sections in the same manner as described above until all but the top section are properly in place.

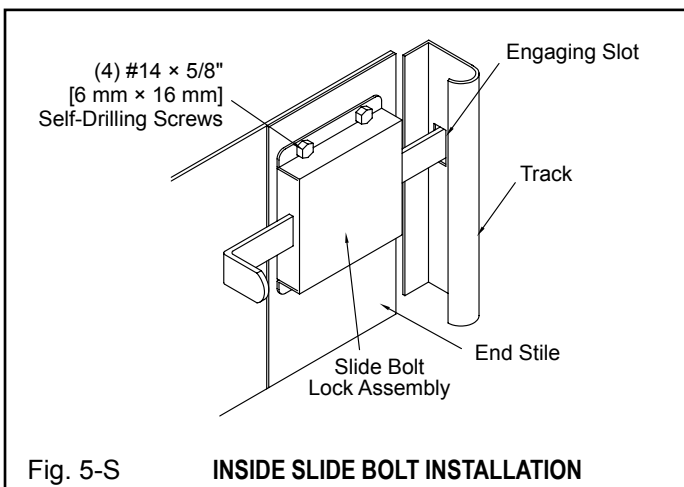

Fig. 5-S

INSIDE SLIDE BOLT INSTALLATION

Outside Lift Handle Template

Line up with top edge of bottom rail of bottom section when locating horizontal outside handle

Line up with outside edges of center stile of bottom section when locating horizontal outside handle

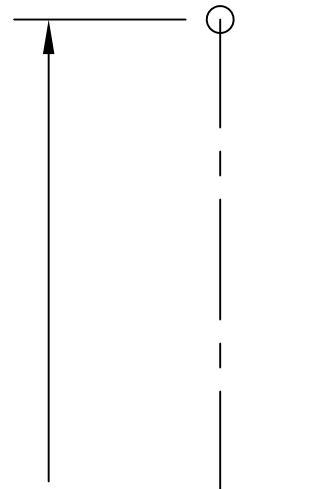

5-1/2"

Vertical center of second section (Use when locating vertical outside handle)

9/64" Dia. Hole (2 places)

Line up with outside edges of center stile of second section when locating vertical outside handle

Cut Along Line

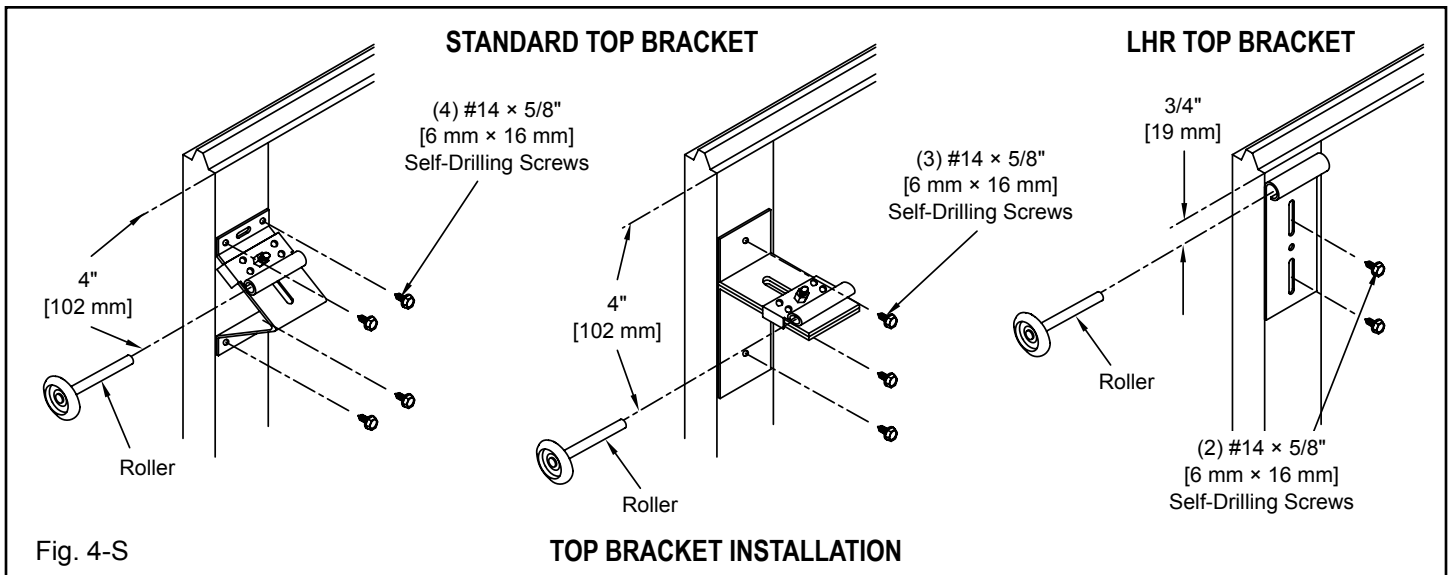

Step 7: Top Section. Reference Hinge and Top Bracket Attachment.

Remember: The small indentations that run the length of the top rail and end stile mark the mounting location (Fig. 4-S).

Install reinforcement angle/strut/channel, if supplied. Refer to "Door Reinforcement Attachment" for instructions.

Stack top section after all tracks are installed, but before springs are wound.

HINGE AND TOP BRACKET ATTACHMENT

End Hinge Attachment:

Step 1: Bottom Leaf Attachment. Remove roller carrier from lower leaf and install end hinges on each end of the section using four (4) #14 x 5/8" [6 mm x 16 mm] self-drilling screws. Hinge holes in the bottom leaf of the hinge should line up to the pre-punched holes on the intermediate rail and end stile (Fig. 5-S).

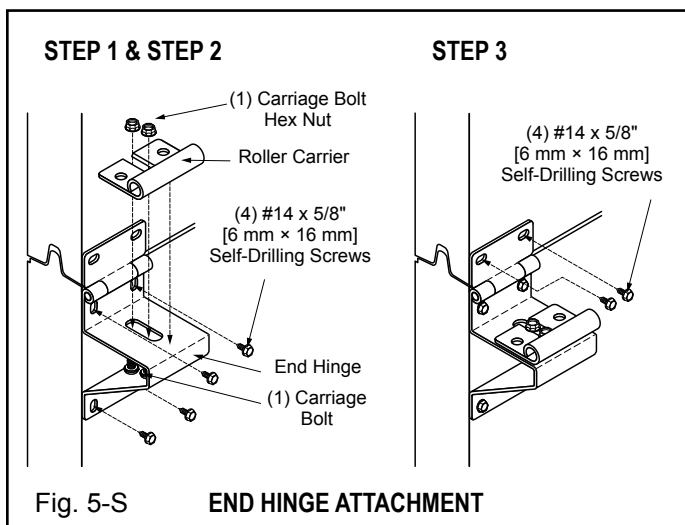

Step 2: Roller Carrier. Slide roller into roller carrier, then install roller into track over the hinge. Reattach roller carrier to lower leaf. Adjust fit and tighten roller carrier bolts.

Step 3: Top Leaf Attachment. Once all sections are stacked, attach the top leaf of each hinge to the section above using two (2) #14 x 5/8" [6 mm x 16 mm] self-drilling screws.

Center Hinge Attachment – Sections without Fin on Intermediate Top Rail:

Step 1: Bottom Leaf Attachment. Hinge holes in the bottom leaf of the hinge should line up to the pre-punched holes on the score lines of the intermediate rail. Use two (2) #14 5/8" [6 mm x 16 mm] self-drilling screws to attach the hinge to the stile.

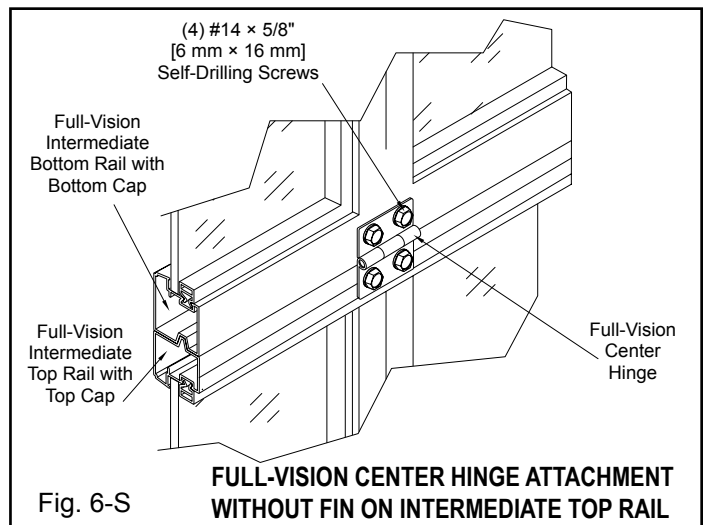

Step 2: Top Leaf Attachment. Once all sections are stacked, attach the top leaf of each hinge to the section above using two (2) #14 × 5/8" [6mm × 16mm] self-drilling screws (Fig. 6-S).

Center Hinge Attachment – Sections with Fin on Intermediate Top Rail:

Step 1: Bottom Leaf Attachment. Hinge holes in the bottom leaf of the hinge should line up to the pre-punched holes in the fin on the intermediate top rail. Use two (2) 1/4" × 5/8" [6 mm × 16 mm] hex head bolts and two (2) 1/4" [6 mm] flange nuts to attach the hinge to the rail.

Step 2: Top Leaf Attachment. Once all sections are stacked, attach the top leaf of each hinge to the section above using two (2) #14 × 5/8" [6 mm × 16 mm] self-drilling screws (Fig. 7-S).

Top Bracket Attachment:

NOTE: It is very important that each top roller bracket be attached to the top rail and end stile.

Step 1: Top Bracket Attachment. Loosen roller carrier and insert roller. Two (2) #14 × 5/8" [6 mm × 16 mm] self-drilling screws should fasten the top of the each bracket to the top rail and two (2) screws should attach the bottom of the roller bracket to the end stile (Fig. 4-S).

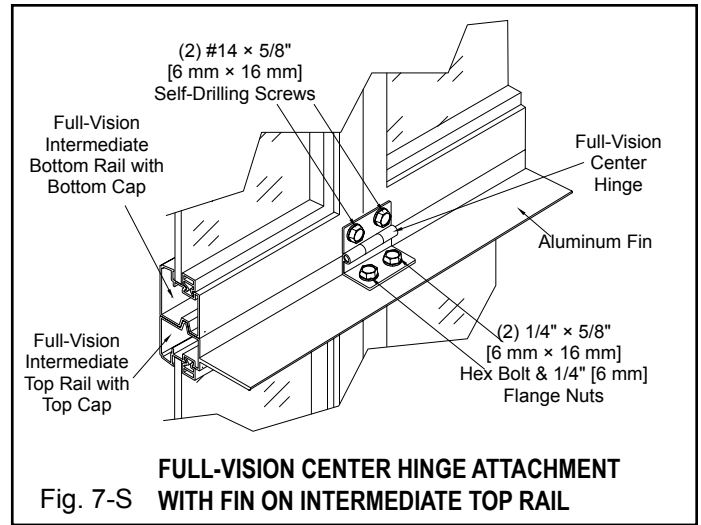

DOOR REINFORCEMENT ATTACHMENT

NOTE: All doors do not require reinforcement. Follow instructions listed below according to the number of angles/struts supplied.

- Number of angles/struts will be shown on hardware box.
- When only one angle/strut is supplied, it is to be mounted on the top section.
- When an equal number of angles/struts and sections are supplied, install one on each section.
- If your door contains fewer angles/struts than sections, evenly distribute them, starting bottom to top.
- When there is one more angle/strut provided than the number of sections, this angle/strut is to be mounted on the bottom section over the bottom bracket.
- Doors installed in high wind load regions (Florida and other hurricane prone areas) may require additional reinforcement beyond what is detailed in this manual. Please refer to wind load drawings.

Aluminum Angle Reinforcement:

Bottom and Intermediate Section:

Step 1: Aluminum Angle Attachment. With section face down on sawhorses, place an angle against the intermediate

top rail fin. Mount the angle to the intermediate top rail fin using two (2) 1/4" × 5/8" [6mm × 16mm] hex head bolts and two (2) 1/4" [6mm] flange nuts at each center stile location. Drill a 1/4" hole at each end through the fin and angle. Secure together using 1/4" × 5/8" [6mm × 16mm] hex head bolts and 1/4" [6mm] flange nuts (Fig 8-S).

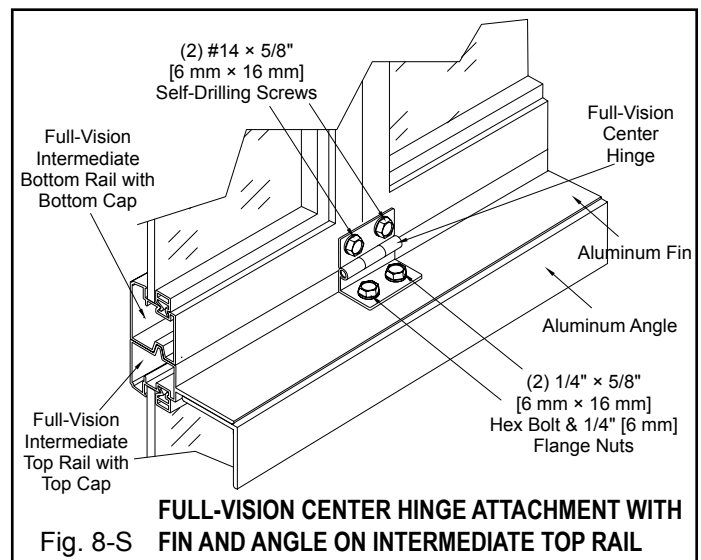

Aluminum Angle Reinforcement:

Top Sections:

Step 1: Aluminum Angle Attachment. With section face down on sawhorses, place the angle against the top rail. Center the angle over the score line in the top rail. Drill a 1/4" hole through the angle and rail at each hinge location and on each end. Secure in place using #14 × 5/8" [6 mm × 16 mm] self-drilling screws (Fig.9-S).

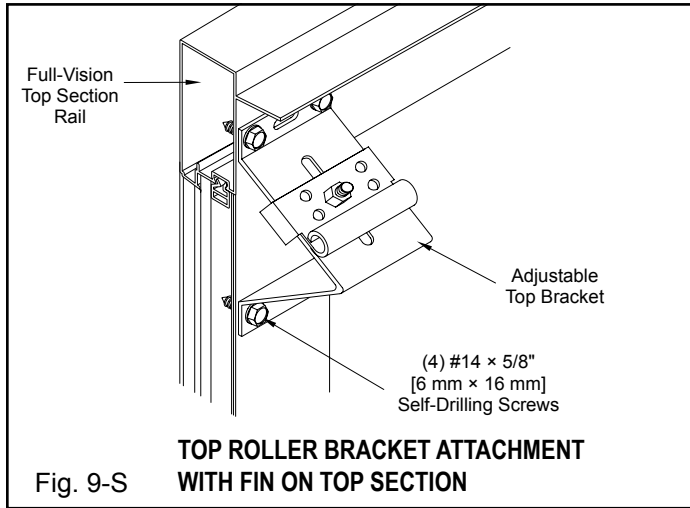

Bridge Strut Reinforcement:

Bottom and Intermediate Sections:

Step 1: Bridge Plate Attachment. With section face down on sawhorses, attach a bridge plate to the intermediate top rail fin at each center hinge location and at each end of the intermediate top rail fin, using two (2) 1/4" × 5/8" [6 mm × 16 mm] hex head bolts and two (2) 1/4" flange nuts.

Step 2: Angle Attachment. Mount an angle to the opposite end of each bridge plate using two (2) 1/4" × 5/8" [6 mm × 16 mm] hex head bolts and two (2) 1/4" [6 mm] flange nuts (Fig. 10-S).

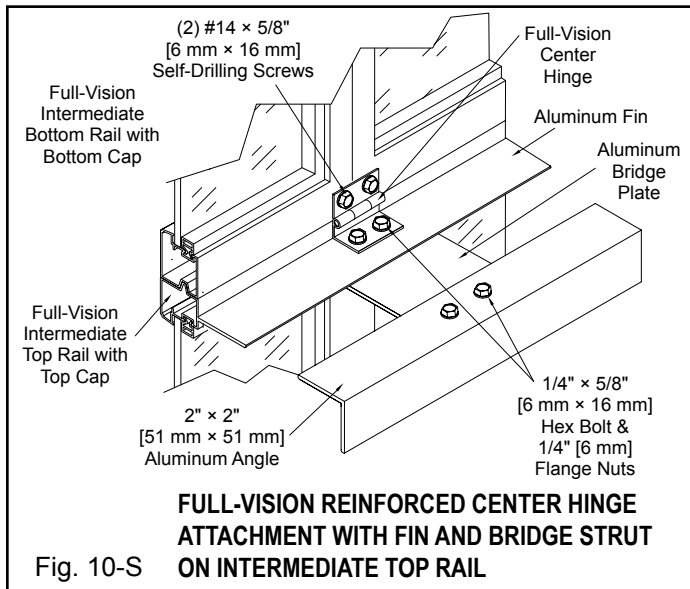

Bridge Strut Reinforcement:

Top Sections:

Step 1: Angle Attachment. With section face down on sawhorses, place an angle against the top rail. Center the angle over the score line in the top rail. Drill a 1/4" hole through the angle and rail at each end of the angle and at each center hinge location. Secure in place using #14 × 5/8" [6 mm × 16 mm] self-drilling screws.

Step 2: Bridge Plate Attachment. Attach a bridge plate at each center hinge location and at each end of the angle, using two (2) 1/4" × 5/8" [6 mm × 16 mm] hex head bolts and two (2) 1/4" flange nuts.

Step 3: Angle Attachment. Mount an angle to the opposite end of each bridge plate using two (2) 1/4" × 5/8" [6 mm × 16 mm] hex head bolts and two (2) 1/4" [6 mm] flange nuts (Fig. 11-S).

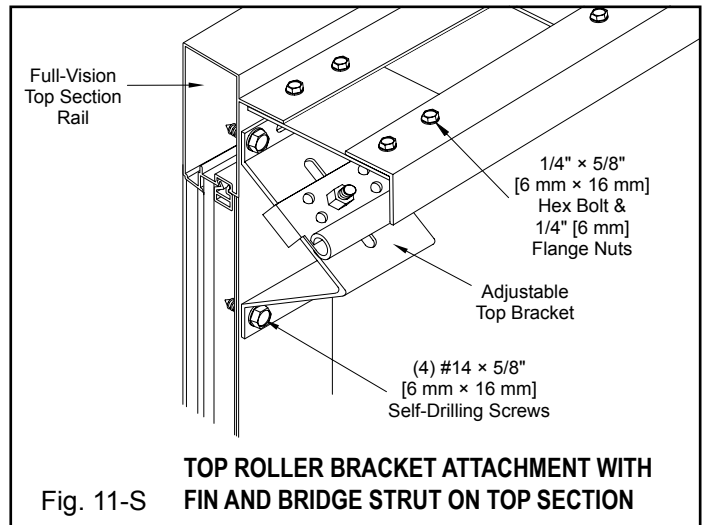

TRACK INSTALLATION

General Information:

There are three (3) basic pieces of information about your tracks that you need to know to start installation.

1) Track size – Track comes in two (2) sizes: 2" [51 mm] and 3" [76 mm].

2) Type of lift – Each type of lift is different from the top of the door on up. However, the vertical track from the floor to the top of the door does not change between the different lift options (Fig. 1-T). Therefore, the vertical track instructions to the top of the door are explained in one group (Step 1). Then turn to your specific type of lift for completion of the installation.

3) Type of mounting – Bracket mounting is used on lighter doors with wood jambs. Brackets are loose or riveted into place. Loose brackets are attached to the track with one 1/4" x 5/8" [6 mm x 16 mm] track bolt and nut per bracket. Continuous angle and reverse angle track are shipped with mounting angle attached. Loosen nuts on track bolts so track will slide on the angle, in order to adjust track as needed (Fig. 1-T).

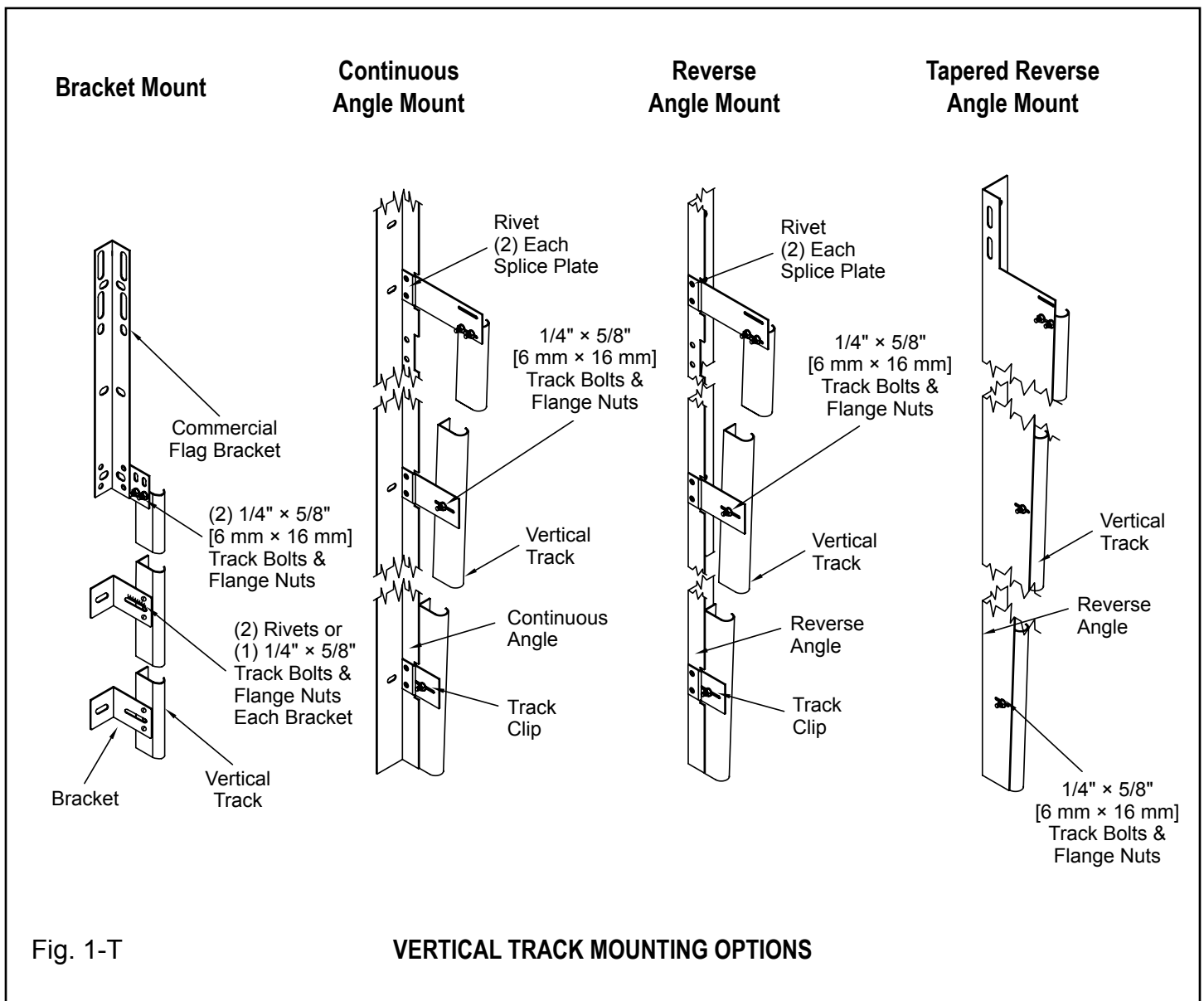

Step 1: Vertical Track. Center bottom section in opening on inside of garage. Level section by shimming low side (Fig. 2-T). Leave shims in place until door install is completed. Install the vertical track on opposite side of where block was placed, over the two (2) rollers of the bottom section with a twisting motion (Fig. 3-T). Raise track 1/2" [13 mm] off the floor and screw 5/16" × 1-5/8" [8 mm × 41 mm] lags (wood jambs) or self-drilling screws (steel jambs) through bottom mounting bracket (Fig. 4-T). Adjust track sideways to allow 1/4" [6 mm] end play in roller about 1/2" [13 mm] (2" track) or 3/4" [19 mm] (3" track) from edge of track to edge of door (Fig 2-T). Plumb vertical track and put at least two (2) lags or sheet metal screws in the mounting brackets at the top of the door. Final adjustment will be made after door is stacked. Measure from the top of the vertical track to the top of the bottom section and set the opposite track at exact same height repeating above procedure (Fig. 2-T). Since the bottom section is level, then the vertical tracks must be level. Make sure bottom rollers do not come out of the bottom of the track.

Step 2: Stacking. Refer to "Preparing and Installing Door Sections" for stacking instructions.

Step 3: Finishing Vertical Track. Set the top of the vertical tracks so that there is a 1/4" [6 mm] end play in the rollers, about 1/2" [13 mm] (2" track) or 3/4" [19 mm] (3" track) from edge of door (Fig. 2-T). Finish attaching vertical track to the wall. If you are mounting to steel jambs, you will have to wait until you can raise the door to finish attaching vertical tracks.

NOTE: To complete the rest of the track installation, refer to the page explaining your specific lift option:

Standard Lift Track	18
Roof Pitch Track	19
High Lift Track.....	20
Vertical Lift Track	21

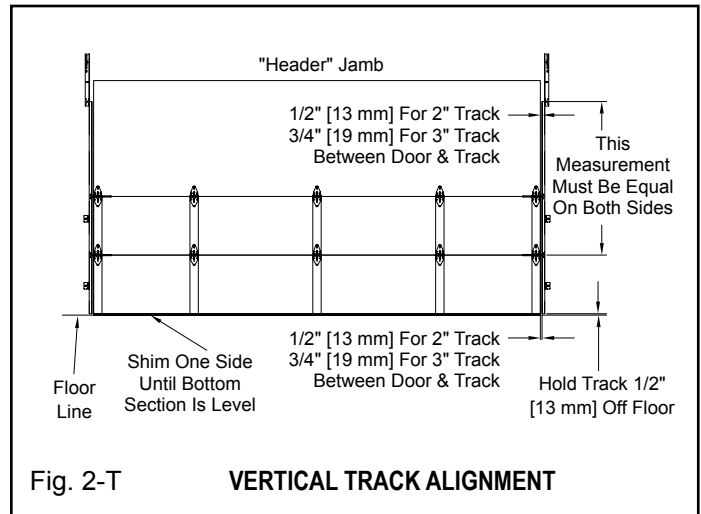

Fig. 2-T

VERTICAL TRACK ALIGNMENT

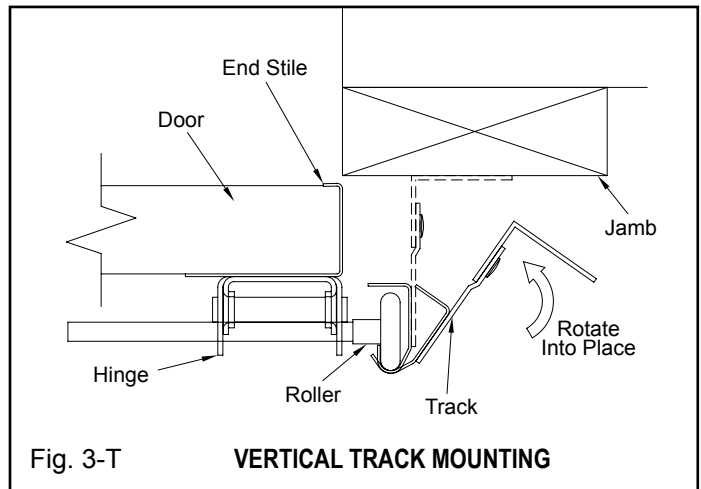

Fig. 3-T

VERTICAL TRACK MOUNTING

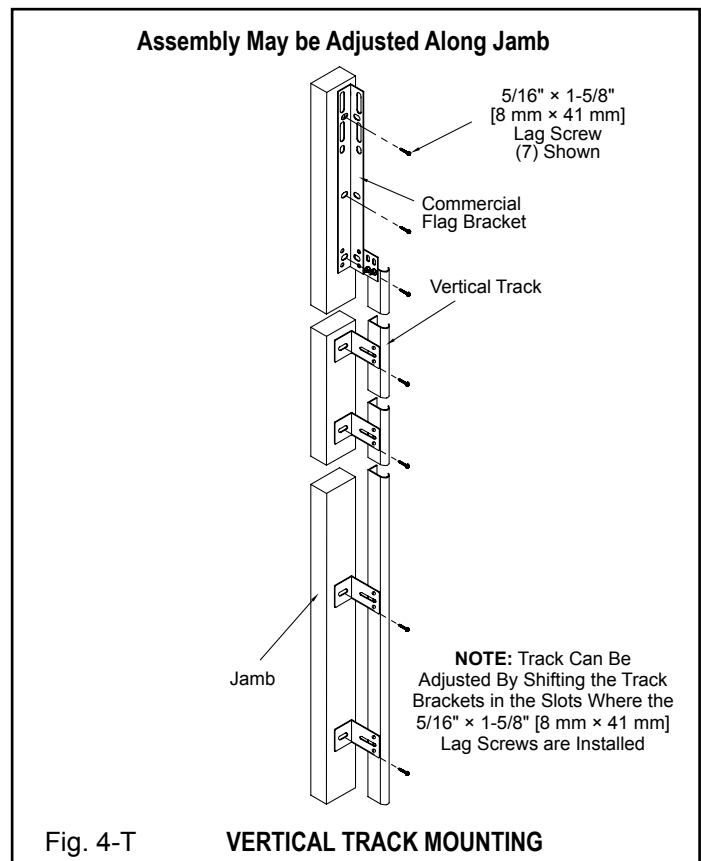

Fig. 4-T

VERTICAL TRACK MOUNTING

IMPORTANT: BACK HANG REQUIREMENTS

NOTE: All doors with horizontal track over 12' 0" [366 cm] require one back hang and one center hang, minimum. Doors with horizontal over 18' 0" [549 cm] require one back hang and two center hangs, minimum. Back hangs and center hangs are evenly spaced on each horizontal track (Fig 5-T). Also, on low headroom track doors, all doors 12' 0" [366 cm] high and under, that are over 600 lbs. [272 kg] or have 1" [25 mm] of sag in horizontal track when the door is in full open position, will require two back hangs evenly spaced on each horizontal track. Inspection of horizontal track is required after completion of garage door installation. With the garage door in the full open position, there should only be 1/4" [6 mm] of free play in rollers and 1/2" [13 mm] (2" track) or 3/4" [19 mm] (3" track) from the edge of the horizontal track to the edge of the door. Realign tracks if necessary.

Standard Lift:

Step 1: Horizontal track install. Attach horizontal track to commercial flag bracket using two (2) 1/4" x 5/8" [6 mm x 16 mm] track bolts and flange nuts. Attach horizontal angle to commercial flag bracket using 3/8" x 3/4" [10 mm x 19 mm] carriage bolts and flange nuts. Temporarily set back hangs for horizontal track or rig a temporary rope to support back of horizontal track. They should be level to 1" [25 mm] higher in the back, parallel to each other and at right angles to the wall when completed (Fig. 5-T).

Step 2: Top Section. Install top section now to other sections. Refer to "Preparing and Installing Door Sections" for instructions.

Step 3: Spring Installation. Install end bearing plates as shown (Fig. 5-T). Refer to "Spring Installation" for additional instruction.

Step 4: Spring Winding. Refer to "Spring Winding" for instructions.

Step 5: Back Hang Doors. After springs are installed and wound, release locking pliers and raise door so that only the two (2) top sections are in the horizontal tracks. Secure door in place with locking pliers on vertical track above a roller, making sure it can't be raised and align horizontal tracks. Back hang doors (Fig. 5-T). **Any door over 12' 0" [366 cm] high requires a center hang and a back hang on each horizontal track.** See "Back Hang Requirements". All back hang material is supplied by the installer.

Step 6: Final Adjustments. Attach spring bumpers, if required (Fig. 8-T). Position bumpers so that door clears opening and the top of the door rests against the bumpers. Drill in place. Use 5/16" x 1" [8 mm x 25 mm] hex head bolts to fasten to track. Refer to "Final Adjustment and Maintenance" to finish install.

⚠ WARNING

Door may come out of the track if spring bumper is not installed.

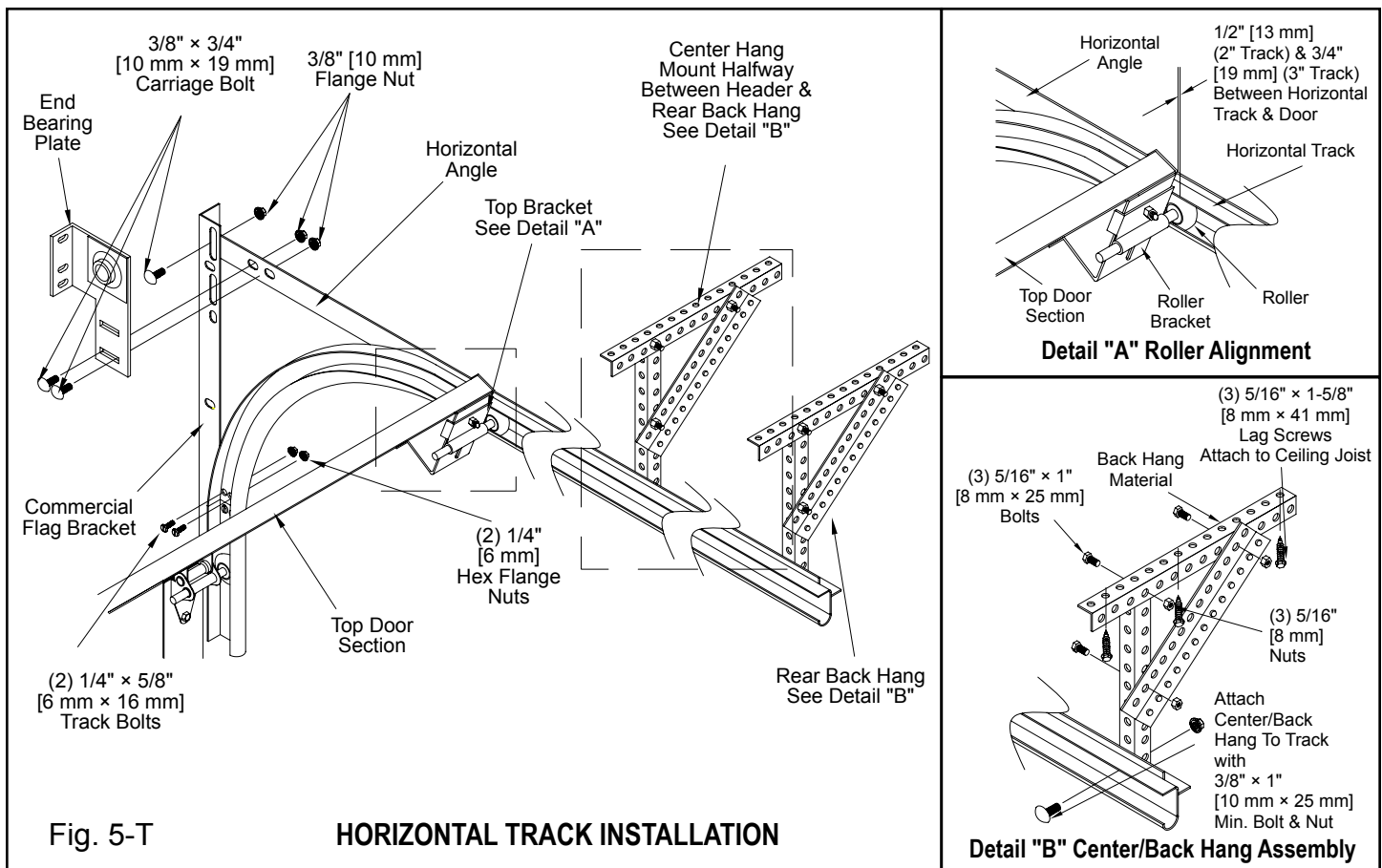

Roof Pitch

Step 1: Horizontal Track Install. Horizontal track follows the pitch of the roof line. An extension angle is mounted, level, just above the radius of the track. Attach horizontal track to commercial flag bracket using (2) 1/4" x 5/8" [6 mm x 16 mm] track bolts and flange nuts. Attach extension angle to horizontal track using 3/8" x 1-1/4" [10 mm x 32 mm] slotted truss head bolt and nut. Attach extension angle to commercial flag bracket using a 3/8" x 3/4" [10 mm x 19 mm] carriage bolt and flange nut. Temporarily set back hangs for horizontal track or rig a temporary rope to support back of horizontal track (Fig. 6-T).

Step 2: Top Section. Install top section to other sections. Refer to "Preparing and Installing Door".

Step 3: Spring Installation. Install end bearing plates as shown (Fig. 6-T). Refer to "Spring Installation" for additional instructions.

Step 4: Spring Winding. Refer to "Spring Winding" for instructions.

Step 5: Backhang Doors. After springs are installed and wound, release locking pliers and raise door so that only the two top sections are in the horizontal tracks. Secure door in place with locking pliers on vertical track above a roller, making sure it can't be raised, and align horizontal tracks. Backhang doors. Any door over 12' [366 cm] high requires a center hang and a backhang on each horizontal track. See "Backhang Requirements" for backhang requirements. All backhang material is supplied by the installer.

Step 6: Final Adjustment. Refer to "Final Adjustment and Maintenance" for instructions.

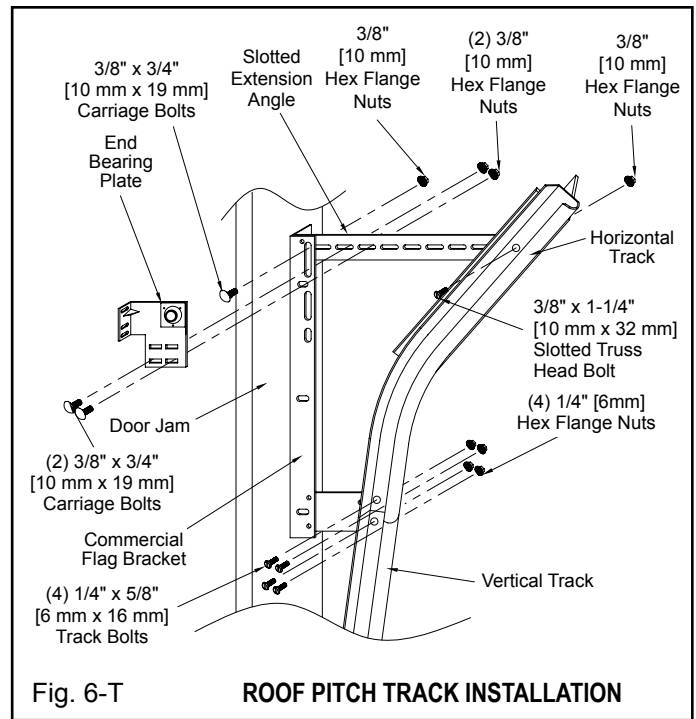

High Lift Track:

Step 1: Lower Vertical Track. Some doors with smaller amounts of high lift will come with vertical tracks in one piece plus the horizontal tracks. Larger high lift doors will have the vertical track in two (2) pieces plus the horizontals.

Follow the vertical track installation instructions for the lower part of the track, from floor to the top of the door.

Step 2: Upper Vertical Track. Starting at the top of the lower track, plumb upper vertical tracks to lower vertical tracks. Attach upper track to lower track using 1/4" x 5/8" [6 mm x 16 mm] track bolts. Attach to jamb with lags/screws in the mounting angles (Fig. 7-T).

Step 3: Horizontal Track. Attach horizontal track to vertical angle using two (2) 1/4" x 5/8" [6 mm x 16 mm] track bolts and flange nuts. Attach extension plate to horizontal angle then attach to vertical angle using 3/8" x 3/4" [10 mm x 19 mm] carriage bolts and flange nuts (Fig. 7-T). Temporarily set back hangs for horizontal track or rig a temporary rope to support back of horizontal track.

Step 4: Top Section. Install top section to other sections. Refer to "Preparing and Installing Door Sections".

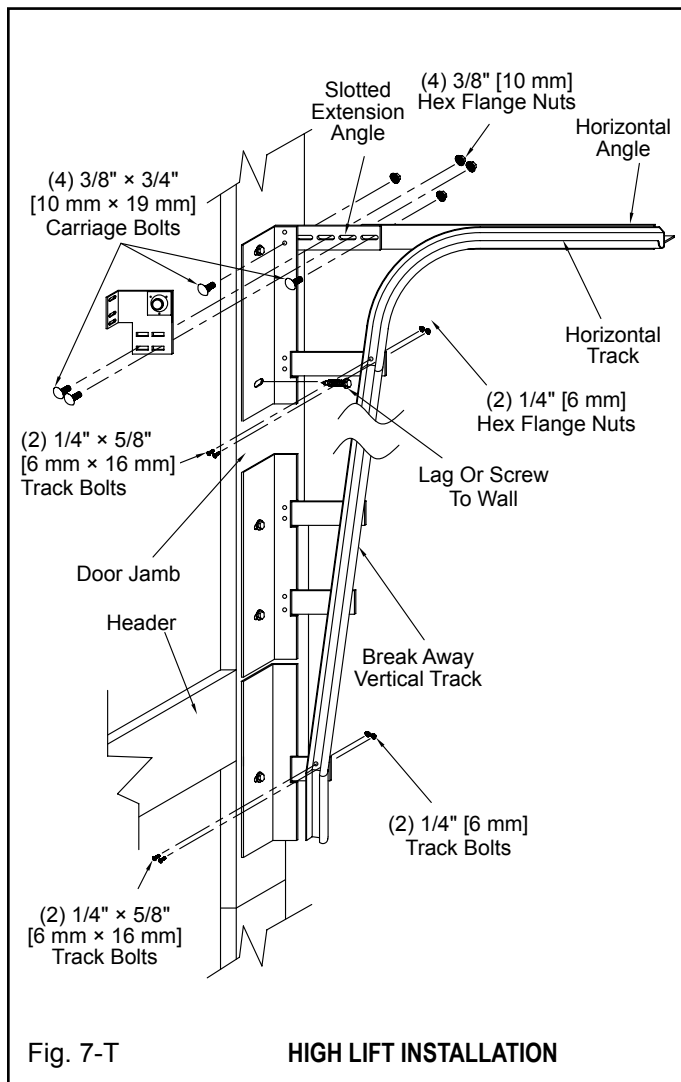

Step 5: Spring Installation. Install end bearing plates as shown (Fig. 7-T). Refer to "Spring Installation" for additional instructions.

Step 6: Spring Winding. Refer to "Spring Winding" for instructions.

Step 7: Back Hang Doors. After springs are installed and wound, release locking pliers and raise door so that only the two (2) top sections are in the horizontal tracks. Secure door in place with locking pliers on vertical track above a roller, making sure it can't be raised and align horizontal tracks. Back hang doors. Any horizontal track over 11' 6" [350 cm] high requires a center hang and a back hang on each horizontal track. See "Back Hang Requirements". All back hang material is supplied by the installer.

Step 8: Final Adjustment. Attach spring bumpers, if required (Fig. 8-T). Position bumpers so that door clears opening and the top of the door rests against the bumpers. Drill in place. Use 5/16" x 1" [8 mm x 25 mm] hex head bolts to fasten to track. Refer to "Final Adjustment and Maintenance" for additional instruction.

⚠ WARNING

Door may come out of track if spring bumper is not installed.

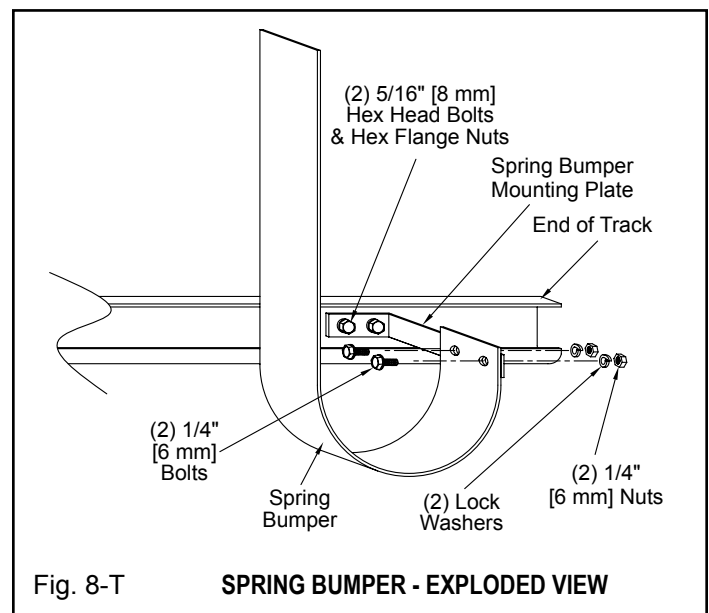

Vertical Lift Track

Step 1: Vertical Track Install. Vertical lift tracks are built as one piece or as two pieces per side, depending on door height.

Follow the vertical track installation instructions for the lower part of the track, from floor to the top of the door.

Step 2: Upper Vertical Track Install. Starting at the top of the door, plumb upper vertical tracks to lower vertical tracks. Attach upper track to lower track using 1/4" x 5/8" [6 mm x 16 mm] track bolts. Attach to jamb with lags/screws in the mounting angles. Temporarily set sway braces for upper track (Fig. 9-T).

Step 3: Top Section. Install top section now to other sections. Refer to "Preparing and Installing Door".

Step 4: Spring Installation. Install end bearing plates as shown (Fig. 9-T). Refer to "Spring Installation" for additional instruction.

Step 5: Spring Winding. Refer to "Spring Winding" for instructions.

Step 6: Sway Brace Doors. After springs are installed and wound, release locking pliers and raise door **so that only the two top sections** are in the upper tracks. Secure door in place with locking pliers on vertical track above a roller, making sure it can't be raised, and align upper track tracks. Sway brace doors. All sway brace material is supplied by the installer.

⚠ WARNING

Door may fall out of track if the track is improperly aligned.

Step 7: Final Adjustment. Attach spring bumpers (Fig. 10-T). Position bumpers so that door clears opening and the top of the door rests against the bumpers. Drill in place. Use 5/16" x 1" [8 mm x 25 mm] hex head bolts to fasten to track. Refer to "Final Adjustment and Maintenance" for additional instructions.

⚠ WARNING

Door may come out of track if spring bumper is not installed.

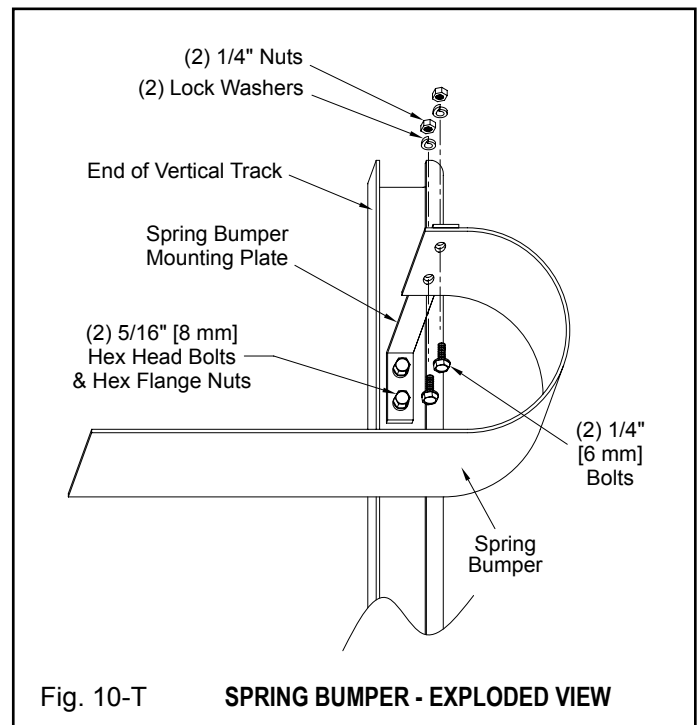
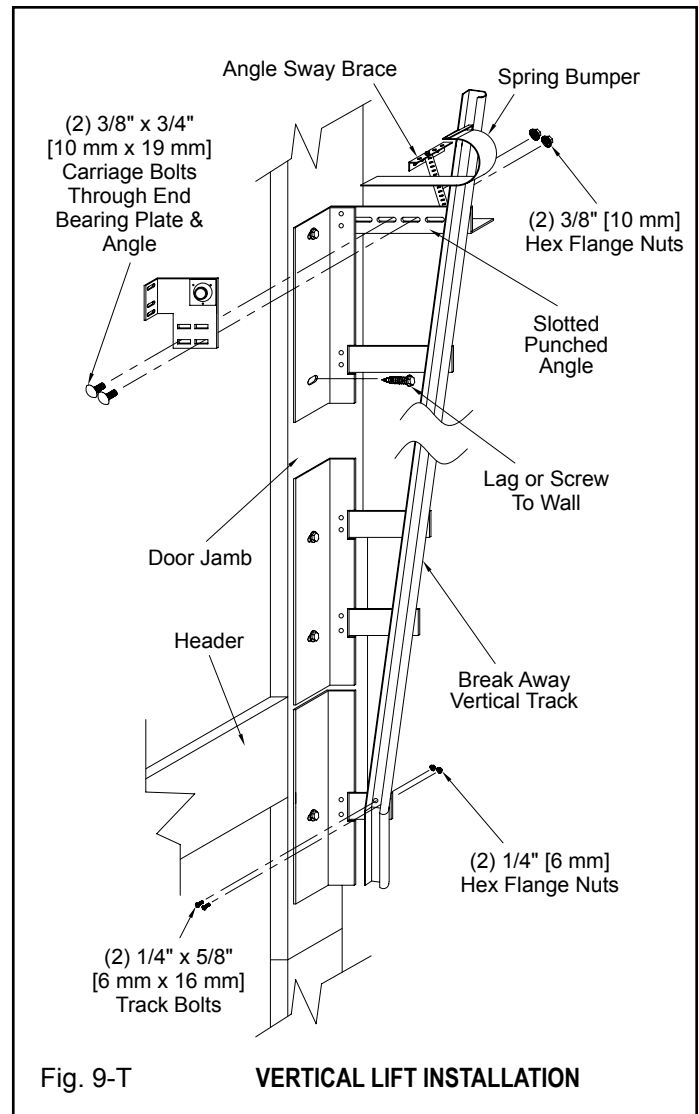

SPRING INSTALLATION

NOTE: This manual covers torsion spring installation ONLY. Reference the supplemental instruction pamphlet provided with this manual for extension spring installation.

NOTE: All torsion spring doors will be furnished with a red warning label. These labels must be on all spring anchor brackets in plain view. These warning labels will be supplied on spring anchor brackets or in the hardware carton. If label is missing, it is the responsibility of the installer to contact their supplier and have them provide needed warning labels for installation.

Step 1: Spring Anchor Bracket Mounting Location. Measure from top of door to center of the end bearings. Draw a straight horizontal line across the header at this height for shaft location and mount spring anchor bracket(s) accordingly. Spring anchor bracket quantity and mounting location(s) are determined by number of springs and door width. Spring anchor brackets require a min. 6" [152 mm] from shaft coupler and a min. 3" [76 mm] from cable drums and other spring assemblies. Refer to Fig. 1-TOR, 2-TOR and 3-TOR for typical arrangements. Determine spring anchor bracket locations and attach an anchor pad at each location.

Step 2: Tube/Shaft Installation. Torsion spring doors require a torsion tube or solid steel shaft. See below for specific process for each.

Torsion Tube Installation:

Step 1: Tube Assembly. Loosen all set screws on springs and drums. Slide springs, shaft bearing and drums on tube. Slide tube into one end bearing plate then back through the opposite end bearing plate. Fasten spring anchor bracket to anchor pad using 5/16" × 1-5/8" [8 mm × 41 mm] red-colored lag screws (wood) or 5/16" × 1" [8 mm × 25 mm] red-colored self-drilling screws (steel). Slide shaft bearing into the stationary cone on spring. Slide spring against spring anchor bracket and attach using two (2) 3/8" [10 mm] cap screw and bolt. Tube must be straight and level (Fig. 1-TOR).

NOTE: Pilot drill in wood with 3/16" [5 mm] drill.

WARNING

Spring anchor brackets anchor the springs to the wall. You must fasten securely with red-colored fasteners. Never remove spring anchor bracket when springs are wound.

Step 2: Drum Positioning. Slide drums against end bearing plates and tighten set screws on one of the drums.

Step 3: Set Screws. Tighten set screws enough to dimple tube, about 1-1/4" turns after set screws first hit shaft.

Step 4: Cable Attachment. Bring cable up between wall and roller shafts behind drum and into notch in edge of

drum. Turn drum and shaft until cable is taught. Make sure cable stop is seated against drum.

Step 5: Component Alignment. Clamp locking pliers on shaft and against header to hold cable taught. Wind cable on other drum, rotate drum until cable is taught and tighten set screws. Tension must be equal on both cables. Cables are now set. See "Spring Winding".

Solid Shaft Installation:

Step 1: Shaft Assembly. Loosen all set screws on springs and drums. Slide springs, shaft bearing and drums on shaft. Install half of shaft coupler (if required). Insert key and tighten set screw. Do not exceed 1/2 turn after coming in contact with shaft.

Step 2: Shaft Mounting. Slide either shaft half into end bearing bracket and fasten spring anchor bracket to anchor pad using 5/16" × 1-5/8" [8 mm × 41 mm] red-colored lag screws (wood) or 5/16" × 1" [8 mm × 25 mm] red-colored self-drilling screws (steel). Center shaft, slide other shaft into opposite side and align shaft coupler. Attach shaft couplers together loosely with coupler bolts and fasten spring anchor brackets. Slide shaft bearing into the stationary cone on spring. Slide spring against spring anchor bracket and attach using two (2) 3/8" × 1-1/2" [10 mm × 38 mm] cap screws and bolts.

WARNING

Spring anchor brackets anchor the springs to the wall. You must fasten securely with red-colored fasteners. Never remove spring anchor bracket when springs are wound.

Step 3: Drum Positioning. Slide both drums against end bearings and insert 1/4" × 1/4" [6 mm × 6 mm] keys and then tighten set screws (Fig. 2-TOR).

Step 4: Cable Attachment. Bring cable up between wall and roller shafts, behind drum and into notch in edge of drum. Turn drum and shaft until cable is tight. Make sure cable stop is seated against drum.

Step 5: Component Alignment. Clamp locking pliers onto shaft and against header to hold cable tight. Repeat procedure for setting cable on the opposite drum. Tension must be equal on both cables. Tighten coupler bolts. Cables are now set. See "Spring Winding".

Auxiliary Shaft Supports (If Required):

Refer to Fig. 1-AT for placement of auxiliary shaft supports, if required. Auxiliary bearings must be assembled to the shaft before drums are put on shaft.

*Used on 20' 0" [610 cm] or wider doors or doors 730 lbs. [331 kg] or greater. To be installed approximately 3" in from drum.

**Used only on doors over 20' 0" [610 cm] wide with only two (2) springs. Auxiliary support bearing is to be installed halfway between spring and drum.

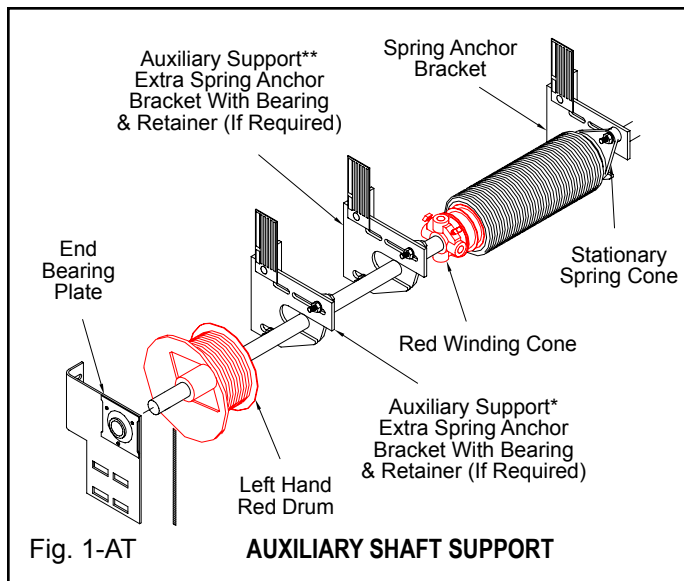

For Torsion Springs Only:

⚠ WARNING

Each spring anchor bracket requires a wood/steel anchor pad. You must make sure that the wood or steel anchor pad condition is of good quality, free of cracks or splits.

IMPORTANT: The wood anchor pad must be made of a Grade 2 or better Southern Yellow Pine (also known as Southern Pine or Yellow Pine) 2" × 6" × 12" [51 mm × 152 mm × 305 mm] minimum. The Southern Yellow Pine must be free of splits and cracks. Do not use wood labeled as Spruce-Pine-Fir (or SPF). Steel anchor pads should be 1/4" × 10" × 12" [6 mm × 254 mm × 305 mm] minimum, securely fastened to the structure.

The wood/steel anchor pad must be installed into the structural frame of the building, not the drywall or sheet rock. Use at least four (4) 3/8" × 3" [10 mm × 76 mm] long lag screws for wood structures or 3/8" [10 mm] masonry anchors for concrete/block structures (one at each corner). Do not install lag screws/masonry anchors less than 1-1/2" [38 mm] from the sides or ends of the anchor pad. Under no circumstances should the anchor pad be attached with nails. Anchor pad and hardware are not supplied.

SPRING WINDING

⚠ WARNING

SPRING TENSION IS DANGEROUS. A sudden release of the springs could result in severe injury. Proceed with caution, following these instructions carefully. Before winding any tension on springs, make sure door is securely locked down with a vise-grip placed on vertical track above a roller. Always use proper size winding bars. Never use screwdriver or any tool too large or too small. They may break and cause serious injury. Stand to the side of winding bars while winding springs.

Step 1: Wind Springs. Draw a straight chalk line across spring. This will indicate the number of turns on the spring as it is wound. Counting the number of wraps minus 1 will equal the number of turns that have been completed. Springs will get longer when wound. Using two (2) cold-rolled steel winding bars about 18" [457 mm] long (not supplied) that fit snugly in the winding plug holes, wind the

springs toward ceiling. Examples shown are generic and may not necessarily match the required spring arrangement for your door.

⚠ WARNING

At this point, springs are fully wound. Springs should stretch easily. Do not force, as it could break the winding plug and cause injury.

Step 2: Set Screws. The set screw depends on type of tube/shaft used. See Fig. 1-TOR, Fig. 2-TOR, Fig. 3-TOR.

Torque Tube: Tighten set screws enough to dimple shaft, approximately 1-1/4 turns after set screws first hit tube.

Solid Shaft: Do not exceed 1/2 turn after coming in contact with shaft.

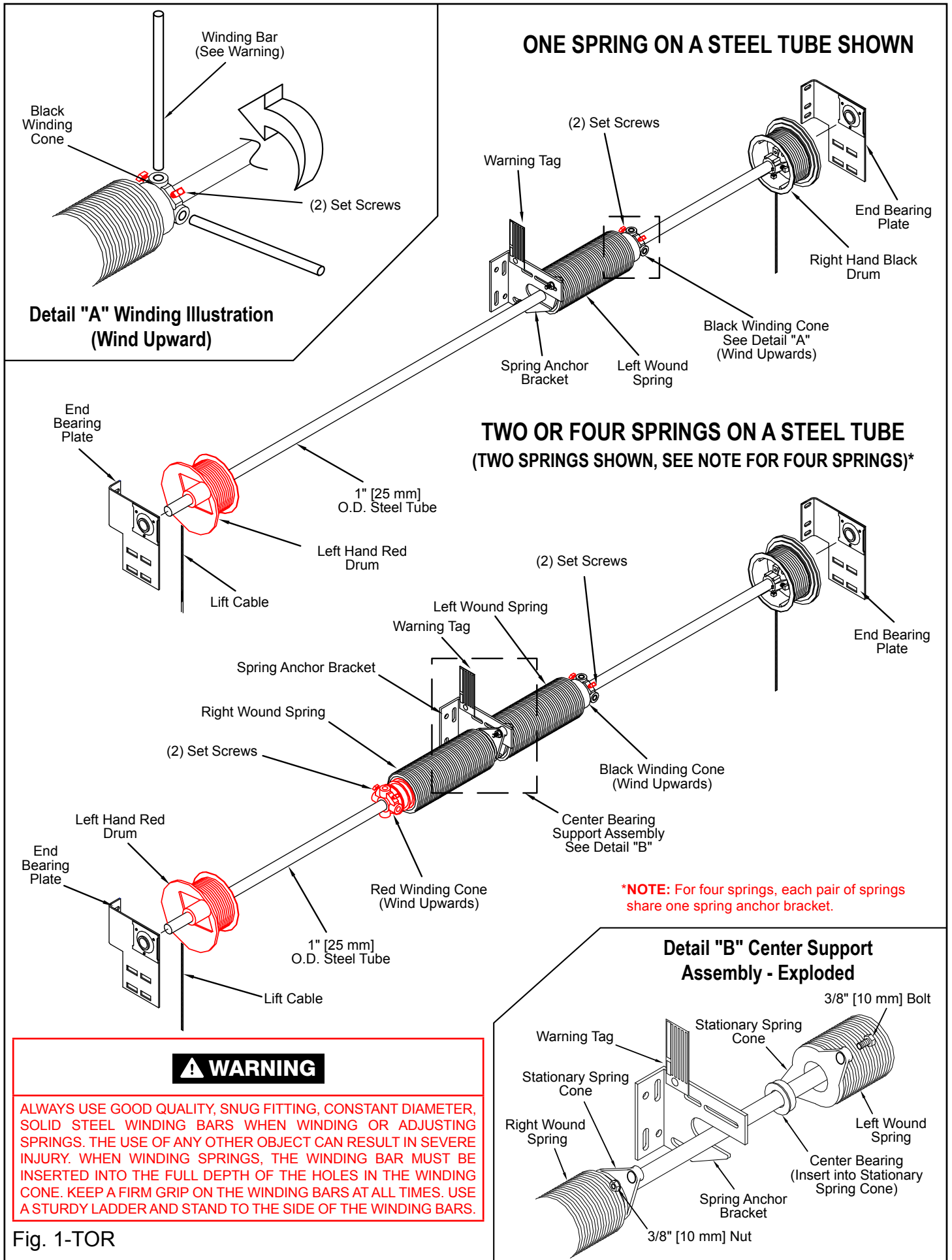

⚠ WARNING

ALWAYS USE GOOD QUALITY, SNUG FITTING, CONSTANT DIAMETER, SOLID STEEL WINDING BARS WHEN WINDING OR ADJUSTING SPRINGS. THE USE OF ANY OTHER OBJECT CAN RESULT IN SEVERE INJURY. WHEN WINDING SPRINGS, THE WINDING BAR MUST BE INSERTED INTO THE FULL DEPTH OF THE HOLES IN THE WINDING CONE. KEEP A FIRM GRIP ON THE WINDING BARS AT ALL TIMES. USE A STURDY LADDER AND STAND TO THE SIDE OF THE WINDING BARS.

Fig. 1-TOR

**Detail "A" Right Hand Drum Attachment
(Left Hand Drum Is Mirrored)**

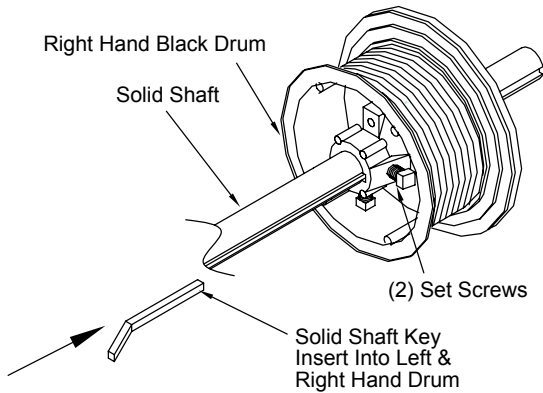

**Detail "B" Winding Illustration
(Wind Upward)**

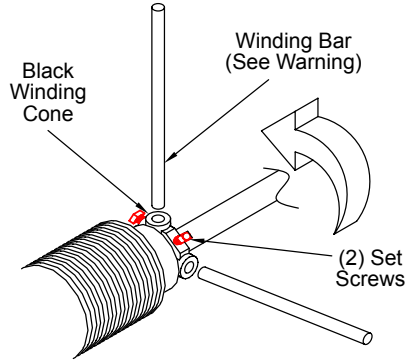

TWO SPRINGS ON A SOLID SHAFT SHOWN

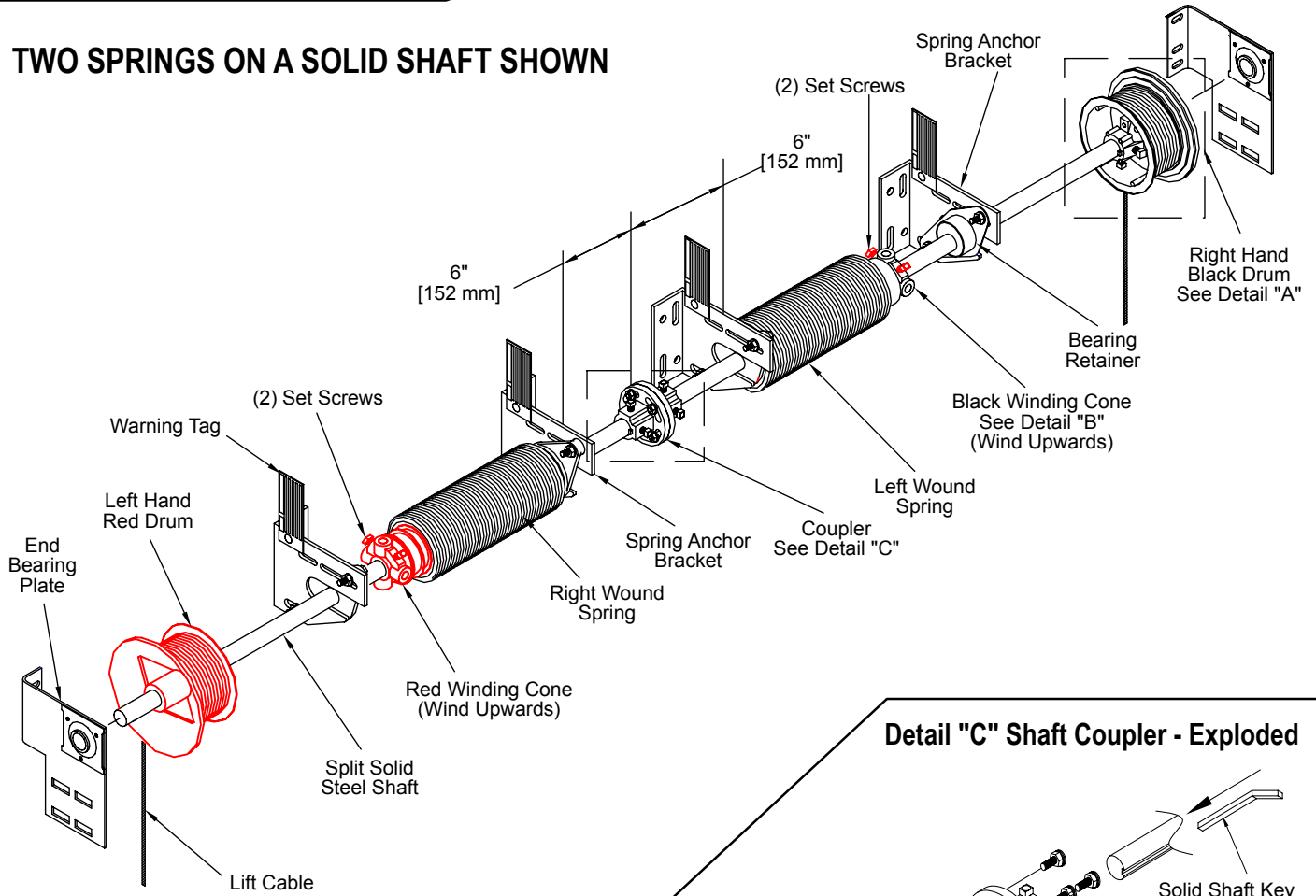

Detail "C" Shaft Coupler - Exploded

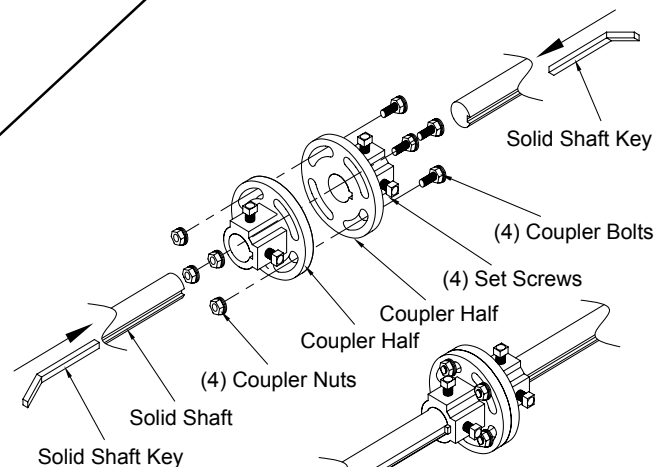

Shaft Coupler - Assembled

⚠ WARNING

ALWAYS USE GOOD QUALITY, SNUG FITTING, CONSTANT DIAMETER, SOLID STEEL WINDING BARS WHEN WINDING OR ADJUSTING SPRINGS. THE USE OF ANY OTHER OBJECT CAN RESULT IN SEVERE INJURY. WHEN WINDING SPRINGS, THE WINDING BAR MUST BE INSERTED INTO THE FULL DEPTH OF THE HOLES IN THE WINDING CONE. KEEP A FIRM GRIP ON THE WINDING BARS AT ALL TIMES. USE A STURDY LADDER AND STAND TO THE SIDE OF THE WINDING BARS.

Fig. 2-TOR

Detail "A" Supplemental Bearing Support Assembly - Exploded

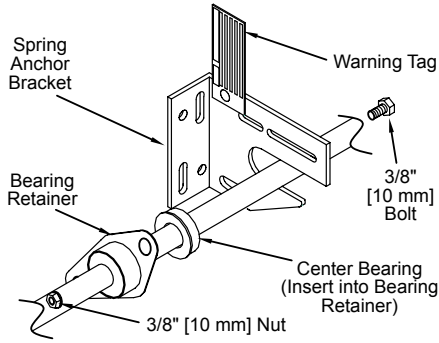

Detail "B" Center Support Assembly - Exploded

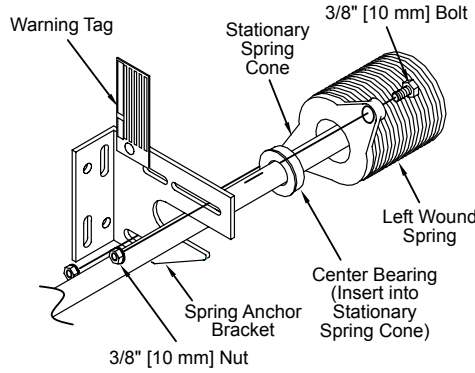

FOUR SPRINGS ON A SOLID SHAFT SHOWN (SEE NOTE)*

***NOTE:** 2" and 2-5/8" dia. springs can be mounted in the arrangement shown in Fig. 1-TOR.

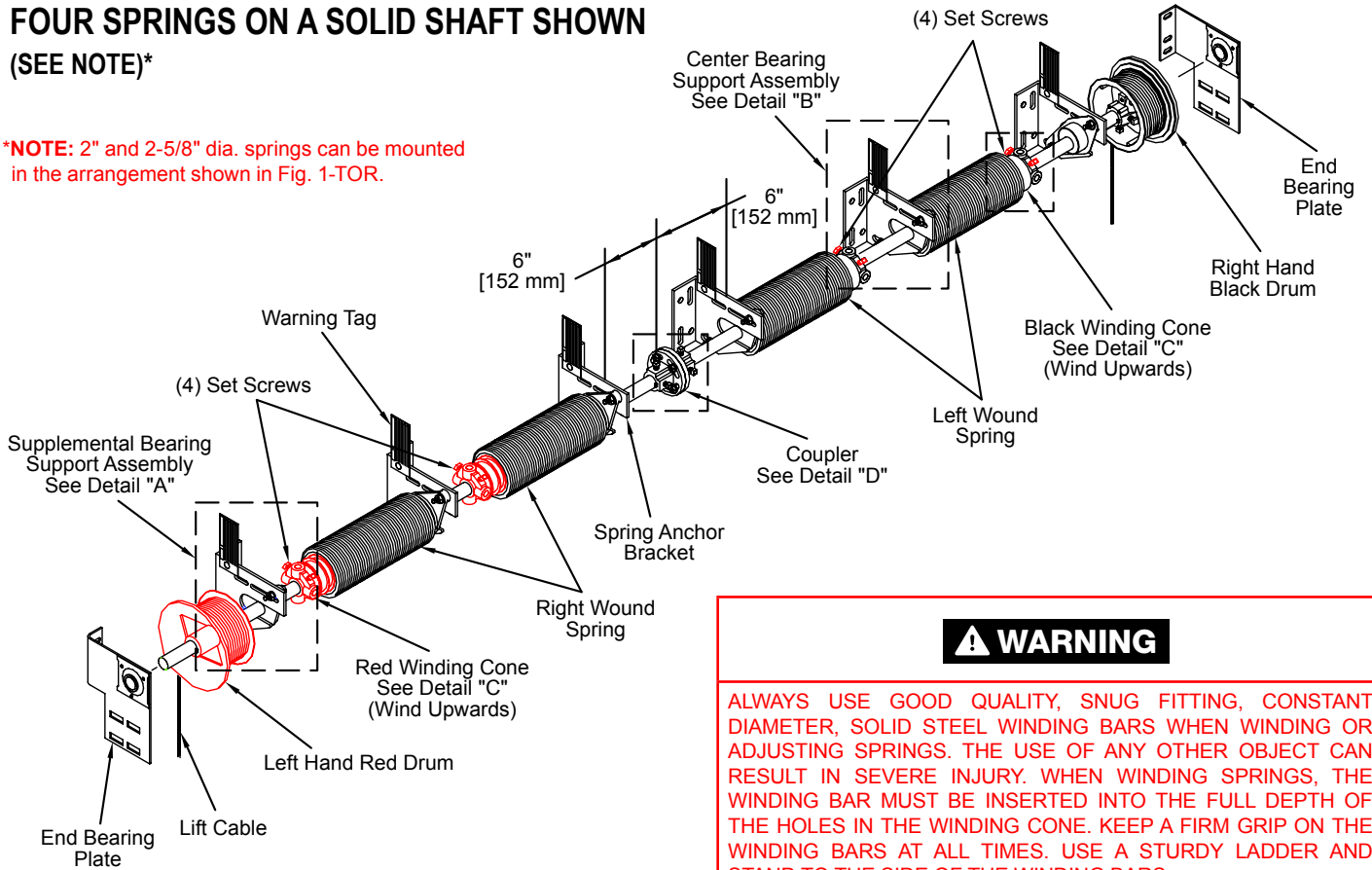

⚠ WARNING

ALWAYS USE GOOD QUALITY, SNUG FITTING, CONSTANT DIAMETER, SOLID STEEL WINDING BARS WHEN WINDING OR ADJUSTING SPRINGS. THE USE OF ANY OTHER OBJECT CAN RESULT IN SEVERE INJURY. WHEN WINDING SPRINGS, THE WINDING BAR MUST BE INSERTED INTO THE FULL DEPTH OF THE HOLES IN THE WINDING CONE. KEEP A FIRM GRIP ON THE WINDING BARS AT ALL TIMES. USE A STURDY LADDER AND STAND TO THE SIDE OF THE WINDING BARS.

Detail "C" Winding Illustration (Wind Upward)

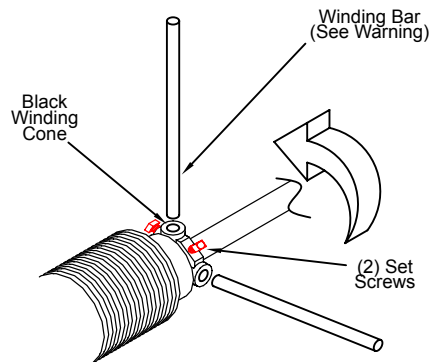

Detail "D" Shaft Coupler - Exploded

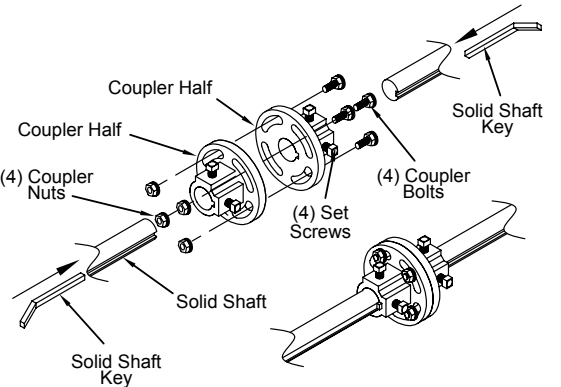

Shaft Coupler - Assembled

Fig. 3-TOR

FINAL ADJUSTMENT AND MAINTENANCE

Final Adjustment:

Step 1: Door Position. Lower door into closed position. Push track (if adjustable) toward jambs until door is tight against door stop/steel jambs.

Step 2: Track. If required, adjust track for fit. Tighten track bolts.

Step 3: Top Brackets. Adjust top brackets. Tighten roller carrier bolts.

Step 4: Lubricate. Lubricate all moving parts (hinges, rollers bearings, springs, etc.) with lightweight oil.

Maintenance:

Lubricate all moving parts approximately every six (6) months. High use doors will require more frequent lubricating.

Every six (6) months, with the door in the closed position, inspect door for the following:

⚠ CAUTION

Do not attempt to adjust door components unless you are a qualified door mechanic.

- Worn or frayed cables
- Loose or bent hinges
- Rollers with broken wheels, bent shafts or worn out bearings
- Loose or missing bolts, screws and other fasteners on the door or track

- Creases or bends in the track
- Damaged or broken springs or spring components
- Worn out bearings in end bearing plates and spring anchor brackets
- Track alignment
- Back hang angle and sway brace attachments

Every twelve (12) months, with the door in closed position, inspect door for the following:

⚠ WARNING

If glass or retainers appear to be or feel loose, warped, cracked, broken, shrunken or misshaped, immediately discontinue use of the door. Failure to do so may result in glass falling out of the pane, causing property damage, serious injury or death.

- From the inside and outside the door, visually inspect all glass panels to ensure they are not loose, cracked or warped.
- From inside the door visually inspect the edge of each glass retainer for any shrinkage, loosening, cracking, warping or misshaping. Proper retainers should appear flat, straight and flush with the window/aluminum panel.
- Physically inspect retainers by pressing the center of each retainer. The inspector should feel little to no movement and not be able to compress the retainer more than 1/8".

CLEANING AND PRESERVING THE DOOR

NOTE: Doors must be cleaned two (2) or four (4) times a year depending on environment. Failure to do so may result in loss of warranty coverage.

Working from top to bottom of the door sections, use a well soaked cloth, sponge or soft bristle brush.

Use a household liquid dishwashing detergent to clean more soiled areas.

A fine scouring pad may be used for heavy surface soils. Be sure to scrub with the direction of the metal grain and do not apply too much pressure.

DO NOT use scouring powders or solvents, alkaline or acid cleaners.

Avoid cleaning in the hot sun.

Rinse door with clean water to complete cleaning and allow to dry.

PAINTING

Surface damage can easily be repaired, provided the damage is slight: such as a small scratch or rub mark. See instructions below for the appropriate finish.

NOTE: For more severe damage or repainting, contacting a professional who specializes in the refinishing of architectural metals is recommended.

Anodized Aluminum Finish

Step 1: Prepare The Area. Rub marks can be removed with a mild abrasive pad such as the Scotch-Brite™ pad prior to touch-up painting.

NOTE: DO NOT sand anodized material when touching up.

Step 2: Clean. Clean the area to be touched up with denatured alcohol to remove moisture.

Step 3: Paint. Apply touch-up paint (not provided), very sparingly. This is intended for small blemishes, less than a few square inches.

Painted Aluminum Finish

Step 1: Prepare The Area. Minor damage to the painted surface should be sanded prior to application of touch-up paint.

Step 2: Clean. Clean the area with denatured alcohol to remove moisture.

Step 3: Paint. Apply the provided touch-up paint, very sparingly. This is intended for small blemishes, less than a few square inches.

WINDOW CARE AND REPLACEMENT

Window Care

For all glass types other than acrylic or polycarbonate glazing: Clean with a mild solution of a dishwashing detergent and a soft cloth. DO NOT use any ammoniated, abrasive or solvent based cleaners of any kind.

For acrylic or polycarbonate glazing: Use a clean, soft sponge or cloth with a mild dish soap and lukewarm water. Dry with soft cloth or chamois to prevent spotting.

DO NOT use any ammoniated, abrasive or solvent-based cleaners of any kind. DO NOT brush, scrub or scrape these windows. After cleaning, rinse thoroughly.

Window Replacement

Reference Full-Vision Glass Installation Supplemental Instructions (P/N: 0137396), included with this manual, for window replacement or contact an authorized professional dealer.

ATTACHING AN AUTOMATIC JACKSHAFT OR TROLLEY OPERATOR

⚠ WARNING

To avoid risk of strangulation or personal injury to children you must remove the pull down rope when you install an automatic operator.

NOTE: Failure to follow instructions as described and provided by the operator manufacture, may result in loss of warranty coverage.

Operator availability per track/door configuration:

Track System	Doors, one (1) panel wide	Doors, two (2) or more panels wide
Standard Lift	Jackshaft*	Jackshaft* or Trolley
High Lift/Vertical Lift/Roof Pitch	Jackshaft	Jackshaft

* Requires the use of cable snubber device and pusher springs.

Jackshaft Operator Installation:

Step 1: Jackshaft operators require an extended solid spring shaft for proper installation and operation. Additional side room on either side of the door for mounting is also required. Reference operator installation instructions, provided by the operator manufacturer for the necessary amount of side room.

Step 2: Install operator as instructed by the operator manufacturer.

Trolley Operator Installation:

Step 1: Remove fasteners from top leaf of the three or four hinges closest to or at center of door that are connecting the top two (2) sections. Place one (1) 8' long piece of 14 gauge 2" x 2" punched angle iron over top leaves and re-install fasteners through the angle (Fig. 1-OP).

Step 2: Attach a second 8' long piece of 14 gauge 2" x 2" punched angle iron across top of section, unless there is already existing door reinforcement present.

Use #14 x 3/4" [6mm x 19mm] self-drilling screws to attach punched angle iron (Fig. 1-OP).

Step 3: Cut a third piece of punched angle iron to span from top horizontal angle/door reinforcement to bottom horizontal angle. Place vertical angle directly above stile nearest to or at center of door. Attach vertical angle through top and bottom angles to section below with #14 × 3/4" [6mm × 19mm] self-drilling screws (Fig. 1-OP).

Step 4: Install operator as instructed by the operator manufacturer.

Step 5: Attach operator arm of trolley operator to short vertical angle.

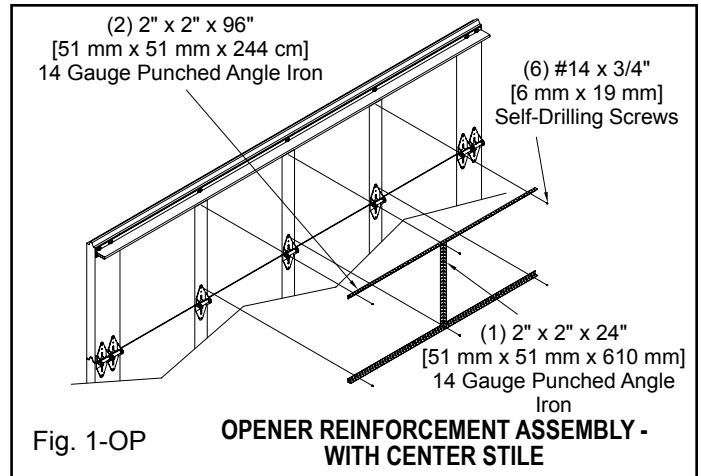

CABLE SNUBBER DEVICE AND PUSHER SPRING

⚠ WARNING

Pusher springs and cable snubber devices are required for any door that has standard lift track and is operated with a jackshaft operator. Without these devices, the cable can go slack and slip off the cable drum allowing the door to crash down causing severe injury or death.

Cable Snubber Device Installation

In addition to the following, also review the installation instructions from the cable snubber manufacturer (supplied with cable snubbers).

Place metal spacers, two (2) per bottom bracket, above saddle with the centered red-headed fastener inside the slot as shown (Fig. 1-CS).

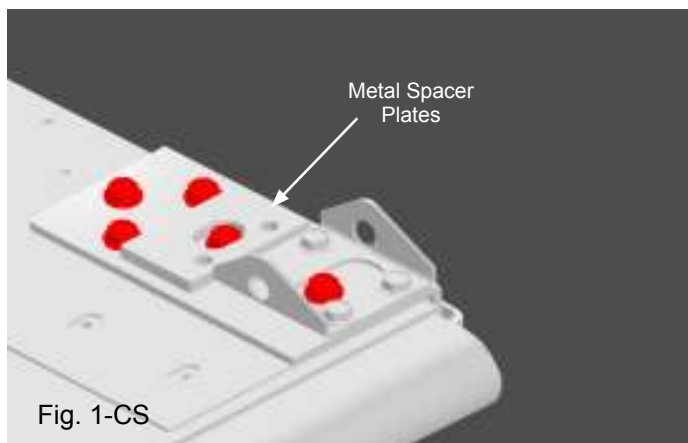

Place cable snubber device on top of metals spacers as shown (Fig. 2-CS).

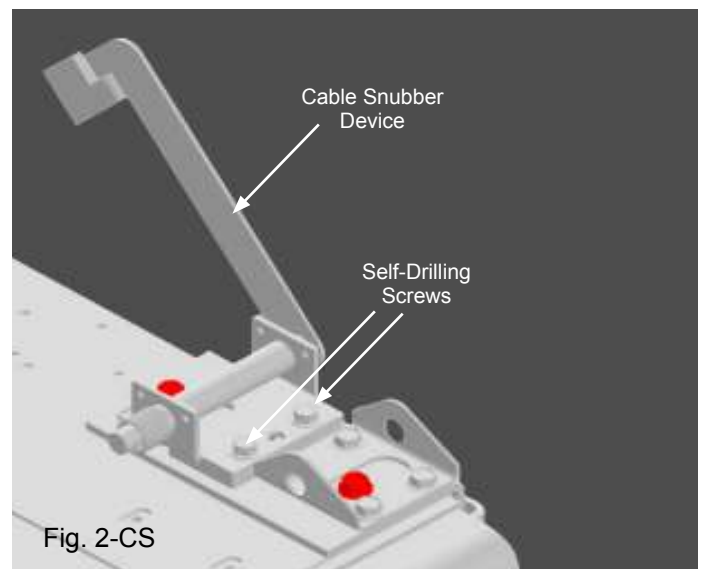

Ensure the cable snubber device arm is no more than 1/8" away from edge of door (Fig. 3-CS).

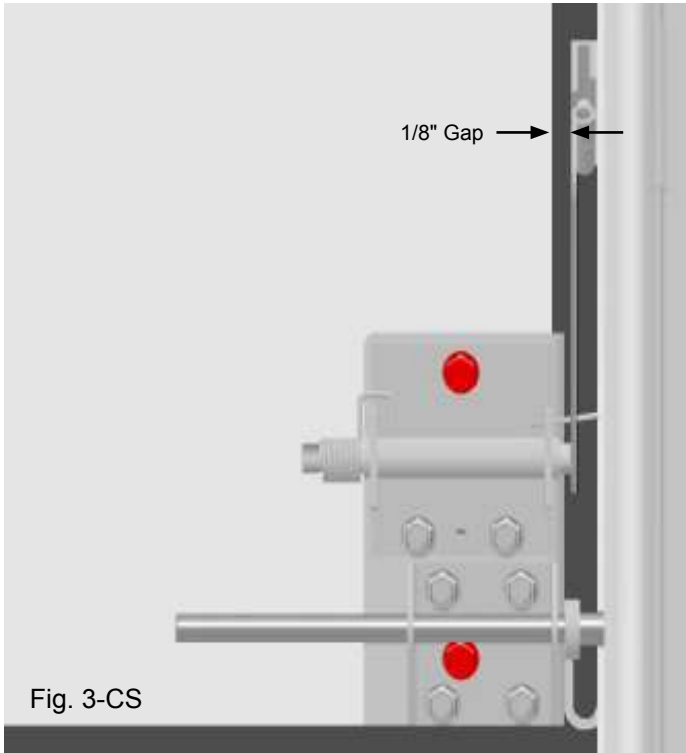

Mark with pencil onto bottom bracket and predrill 3/16" dia. holes through the bottom bracket and end stile.

Fasten cable snubber using two (2) self-drilling screws provided in kit (Fig. 2-CS). Screws use 3/8" driver.

Pusher Spring Installation

Manually open door to full open position desired and mark location of top section edge on track.

Taking 4" to 6" of compression into account, determine location of bracket.

Mark holes with pencil and pre-drill two (2) 3/8" dia. holes.

Fasten pusher spring to track using two (2) 3/8" x 1" bolts and nuts. Pusher spring foot pad should hit squarely and be centered on section.

Fig. 1-PS is traditional side mount locations.

Fig. 2-PS flange mount is an alternative location and the only location available for 3" track.

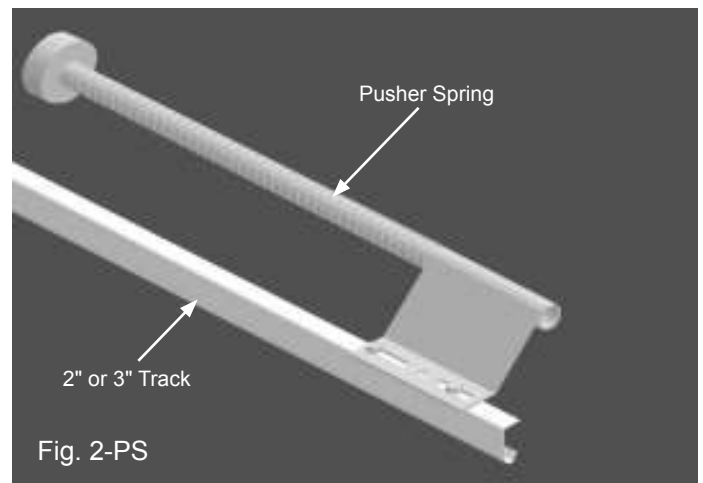
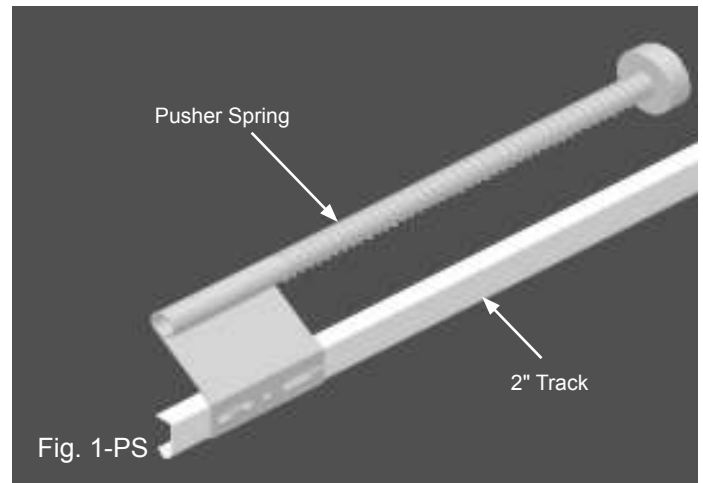

LIMITED WARRANTY

ARCHITECTURAL SERIES – ALUMINUM FULL-VIEW

Subject to the terms of this Limited Warranty (“Warranty”) and any warranty policies and procedures in effect at the time a notice of a claim is received, Clopay Corporation (“Clopay”, “we”, or “our”) will repair or replace - at our sole discretion - any garage door sections/section components, hardware, or springs/spring components (collectively, “Replacement Parts”) that we determine to be defective in material or workmanship so long as timely written notice is provided within the applicable limited warranty periods provided below. This Warranty shall apply and benefit only the original purchaser of a Clopay garage door product (“Product”) and is non-transferable.

The Warranty period begins from the date of delivery. Proof of purchase is required. Once we have verified any defect(s) with your Product through persons authorized by Clopay, we will provide – at no cost to you – Replacement Parts to the extent necessary to repair or replace any such defective sections, hardware, or springs/spring components. We reserve the right to inspect and/or verify any claimed defect, as well as the right to replace Product(s) or its components with a similar or like product or component, all within the sole discretion of Clopay. All labor costs associated with any warranty claim (including removal, reinstallation, installation, and/or finishing) will be your responsibility.

The applicable Warranty periods are as follows:

MODEL NUMBER	PAINT FINISH	MATERIAL & WORKMANSHIP	HARDWARE/SPRINGS
902, 903, 904, 905, 906, 904U, 905U, 906U	Standard Paint - 5 Years Color Blast® - 5 Years RAL Powder Coat Finish - 5 Years	1 YEAR	1 YEAR

ADDITIONAL INFORMATION REGARDING YOUR WARRANTY

Clopay warrants the sections of the Models listed above against the paint finish cracking, checking or peeling (i.e. losing adhesion). Failure to properly clean and maintain your door (particularly in, but not limited to, high-salt or acidic environments) or damage to the door (such as scratching), may result in surface rust, a coating that forms on the surface when exposed to moisture, which – if left untreated – may result in loss of Warranty coverage. Surface rust is not covered under this Warranty. For more information about our rust prevention system and how to care for your door visit: info.garagedoors.com/maintenance.

Insulated windows are warranted for five (5) years for material obstruction of vision resulting from film formation or dust or moisture collection between the interior surface of the insulating glass. No warranty is available for single pane glass.

EXCLUSIONS TO COVERAGE

This Warranty shall not extend to damages or defects caused by any of the following:

Paint or Stain Not Applied per Manufacturer Specifications after Delivery of Door	Failure to Follow All Installation Instructions	Failure to Follow Maintenance Instructions	Faulty or Defective Installation(s)
Fire	Radiation (UV or Other)	Foreign Substances	Accident or Casualty
Harmful Fumes	Vandalism	Act(s) of God	Physical Damage
Salt Spray or Exposure	Normal Wear and Tear	Chemical Action	Abrasive Materials
Operation Beyond Rated Capacity	Improper Use or Abuse	Improper Installation or Handling	Exposure to Coastal Weather Conditions
Alteration, Modification or Use of Non-OEM/ Clopay-Approved Parts or Products	Other Painted Parts Not Part of a Door Section (such as stop mold)	Normal Fading or Discoloration from Usage, Age or UV Exposure	Thermal Bow as Described in DASMA Technical Data Sheet 185 www.dasma.com

If you make any repair or alteration without first providing notice to and receiving authorization from us, or use any parts, accessories, or attachments other than authorized by Clopay for use in its products, you will be solely responsible for any such repairs or parts and you may void this Warranty. Routine maintenance and related items, as well as minor adjustments or damage caused by your installer either during delivery or installation, are excluded from this Warranty. For purposes of this Warranty, minor scratches will not be considered a defect.

If you would like to submit a Warranty claim, notify Clopay Customer Service promptly after discovery of the defect by sending an email to warranty@clopay.com or calling 800-225-6729.

Please be prepared to send us a proof of purchase and complete description with photographs of any issues. YOU MUST REPORT ANY MANUFACTURING DEFECTS THAT ARE IMMEDIATELY OBVIOUS OR VISIBLE AT THE TIME OF INSTALLATION (SUCH AS INCORRECT OR INCONSISTENT PAINT COLOR, MANUFACTURING DEFECTS (E.G. SURFACE CONTAMINANT(S) OR SMUDGES), VISIBLE PHYSICAL DAMAGE, OR MAJOR SCRATCHES) WITHIN FORTY FIVE (45) DAYS FROM DELIVERY OR YOUR CLAIM MAY BE BARRED. Additional copies of our installation and maintenance instructions may be obtained by calling 800-225-6729 or by sending an email to warranty@clopay.com.

UNDER NO CIRCUMSTANCES SHALL WE BE LIABLE FOR ANY CONSEQUENTIAL OR SPECIAL DAMAGES WHICH ANY PERSON OR ENTITY MAY INCUR OR CLAIM TO INCUR AS A RESULT OF ANY DEFECT IN THE PRODUCT OR IN ANY CORRECTION OR ALTERATION THEREOF MADE OR FURNISHED BY US OR OTHERS. OUR MAXIMUM LIABILITY UNDER THIS WARRANTY SHALL BE THE PURCHASE PRICE PAID TO US WITH RESPECT TO THE GARAGE DOOR TO WHICH SUCH WARRANTY IS CLAIMED. THE LIMITATION OF LIABILITY PROVISIONS HEREIN SHALL APPLY TO ANY AND ALL CLAIMS OR SUITS BROUGHT AGAINST US, INCLUDING ANY CLAIM BASED UPON NEGLIGENCE, BREACH OF CONTRACT, BREACH OF WARRANTY, STRICT LIABILITY OR ANY OTHER THEORIES UPON WHICH LIABILITY MAY BE ASSERTED AGAINST US.

This Warranty constitutes our entire and exclusive warranty as to the Product and is the sole and exclusive remedy for product defects in material and workmanship. We do not assume (and have not authorized any other person to assume on its behalf) any other warranty or liability in connection with any product covered by this warranty. WE MAKE NO OTHER WARRANTIES, REPRESENTATIONS OR COVENANTS, EXPRESS OR IMPLIED, WITH RESPECT TO THIS PRODUCT, INCLUDING BUT NOT LIMITED TO WARRANTIES, REPRESENTATIONS OR COVENANTS AS TO WORKMANSHIP, DESIGN, CAPACITY, QUALITY, CONDITION, MERCHANTABILITY OR FITNESS FOR ANY PURPOSE OF THE PRODUCT, EXCEPT FOR ANY “IMPLIED WARRANTY” AS THAT TERM IS DEFINED IN THE MAGNUSON-MOSS WARRANTY-FEDERAL TRADE COMMISSION IMPROVEMENT ACT, SUCH IMPLIED WARRANTIES TO BE LIMITED IN DURATION TO A PERIOD OF ONE YEAR FROM THE DATE OF PURCHASE.

This Warranty gives you specific legal rights, and you may also have other rights that vary from state to state.

To the extent of any conflict between this Warranty and any other document, this Warranty shall control. If Warranty is provided in multiple languages, the English language version shall govern.



© 2022 Clopay Corporation. All rights reserved.

MCW19001E-R04-0522